



2019 – 2020



IGNITION
PARTS



VEHICLE
ELECTRONICS

IGNITION & SENSOR SPECIALIST

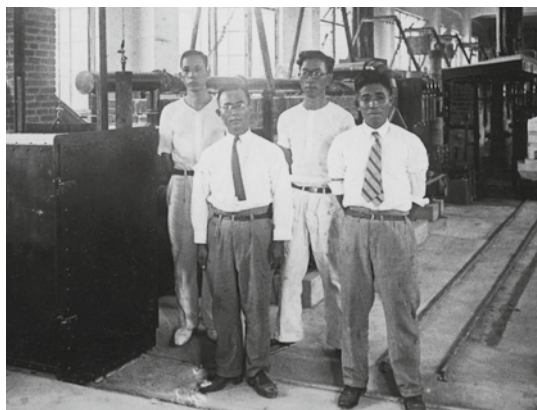

Founded in 1936, the NGK SPARK PLUG Corporate Group, known around the globe as a leading manufacturer of spark plugs, has always developed ceramics as its core competence. Over the years, the company has established a track record of successfully applying the expertise gained in the field of ceramics to other areas to create new value.

Today, NGK SPARK PLUG is a leading manufacturer of ignition parts and vehicle electronics both for OEMs (Original Equipment Manufacturers) and the IAM (Independent Aftermarket) with over 80 years of experience. A total of 43 subsidiaries, 24 production plants, 5 Technical Centers and 14,500 employees around the world ensure optimum processes and a great wealth of knowledge.

The world leader in spark plugs and oxygen sensors, NGK and NTK have built a strong reputation for quality, reliability and a commitment to excellence. Now as then, the ignition and sensor specialist is dedicated to providing customers with world-class products and services.

In order to react more quickly to the global and regional changes of the market and the NGK and NTK environment, the company has switched from a central to a regional company management model. As a result, NGK SPARK PLUG EUROPE GmbH, based in Ratingen, Germany, became the EMEA Regional Headquarter in 2017 and has extended its responsibility from only Europe to include Middle East and Africa. Today, the EMEA markets are key to NGK SPARK PLUG's success, making up 25 percent of NGK's total global sales.



Facebook
facebook.com/ngkntk.emea



YouTube
youtube.com/ngksparkplugeurope



LinkedIn
linkedin.com/company/ngk-spark-plug-europe-gmbh

1979

Foundation of
NGK SPARK PLUG
DEUTSCHLAND GmbH



Launch of the
sensor brand NTK

1982

NGK | **NTK**
SPARK PLUGS | TECHNICAL CERAMICS
NGK SPARK PLUG EUROPE GmbH

1989

NGK SPARK PLUG
DEUTSCHLAND
becomes NGK SPARK
PLUG EUROPE

Production plant in
Orléans (FR) and Technical
Center in Ratingen (DE)
start operation



Launch of V-Line,
the most successful
spark plug assortment

1991

1997



First lambda sensor for
the Aftermarket available



Launch of NGK ignition
coils for the Aftermarket

2012

2014



Introduction of NTK
exhaust gas temperature
sensors

WELLS
VEHICLE ELECTRONICS

Acquisition of Wells,
a leading producer of
ignition coils and
sensors in the U.S.

2015

2016



Launch of NTK MAP/MAF
sensors for the Aftermarket

NGK SPARK PLUG EUROPE
takes over responsibility for
the EMEA region

2017

Opening of the new
Regional Distribution Center
in Duisburg, Germany

GB DE FR IT ES NL



























PT GR TR PL CZ HU RU



IGNITION
PARTS



VEHICLE
ELECTRONICS

 	2 - 27
 	28 - 53
  	54 - 80
 Series	81 - 94
 Series	95 - 118
 	119 - 190
 	191 - 238
 	239 - 254
   	255 - 282
Oxygen Sensors 	283 - 290
   	291 - 292
  Cross Reference Guide → NGK	293 - 390
Discontinued Products	391 - 397
Disclaimer	398 - 408



How to read our part number: Spark Plugs

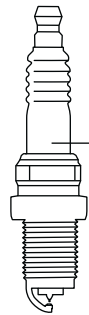

Unit : mm

B			P		R		5		E		S		-11		
Thread size	Hex size	Structure	Resistor		Heat rating		Thread length		Design features		Spark gap				
A	∅ 18.0	Hex 25.4	P	Projected insulator type	R	Resistor	2	<p>Hot type</p> <p>Cold type</p>	E	19.0	B	Integral terminal (CR8EB)	None	Motorcycle : 0.7~0.8	
B	∅ 14.0	Hex 20.8	M	Small spark plug	Z	Inductive resistor type	4		EF	17.5	CM	Slant ground electrode Compact type (Exposed insulator length: 18.5)		Car : 0.8~0.9	
BC	∅ 14.0	Hex 16.0	U	Surface gap, Semi-surface discharge gap or Supplementary gap			5		EH	19.0 half-thread	CS	Slant ground electrode	-8	0.8	
BK	∅ 14.0	Hex 16.0					6		H	12.7	G,GV	Racing spark plug	-9	0.9	
C	∅ 10.0	Hex 16.0					7		L	11.2	None Tapered seat type A(P)-F : 10.9 B(P)-F : 11.2 BM(P)-F : 7.8 Small type plug B(P)M- : 9.5 B-LM : 9.5 CM- : 9.5 CM-6 : 8.6 C-50 : 8.5	I	Iridium central electrode	-10	1.0
D	∅ 12.0	Hex 18.0					8		None	Tapered seat type		IX	Iridium IX spark plug	-11	1.1
DC	∅ 12.0	Hex 16.0					9		J	2-projecting-ground electrodes		-13	1.3		
E	∅ 8.0	Hex 13.0					10		K	2-ground-electrodes		-15	1.5		
*Exception B(P)M-A,Y : ∅ 14.0, Hex 19.0 P(P)-(E)F : ∅ 14.0, Hex 16.0 CM-6 : ∅ 10.0, Hex 14.0 BC : Old JIS standard size The length from gasket surface to terminal contact is 53.0mm. BK : ISO / JIS standard size The length from gasket surface to terminal contact is 50.5mm.															
									-LM Compact type (Insulator length: 14.5) N Special ground electrode P Platinum spark plug Single ground electrode : Double platinum Multi-ground electrode : Single platinum in central electrode Q 4-ground-electrodes S Standard type T 3-ground-electrodes U Semi-surface discharge gap Y V-grooved center electrode Z Special design						



How to read our part number: Spark Plugs

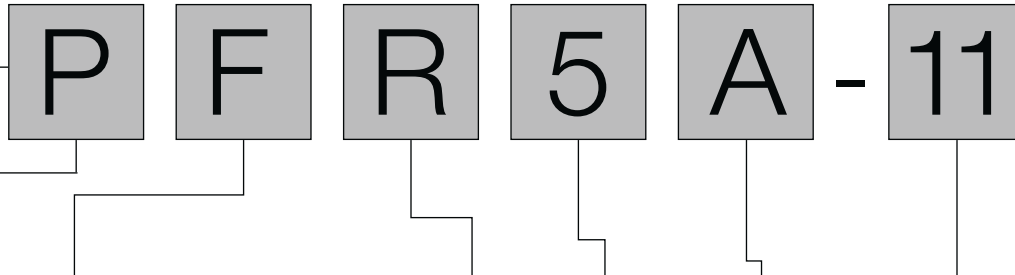
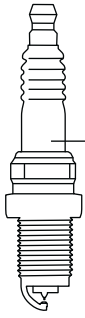

Unit : mm

P		F				R		5		A		-11			
Plug type		Thread diameter	Thread length	Seat configuration	Hex size	Resistor		Heat rating		Design		Spark gap			
DI	High ignitability plug: Double fine electrodes	F	∅ 14.0	19.0	Gasket	Hex 16.0	R	Resistor	2		A,B,C... Suffix code	None	Motorcycle : 0.7-0.8 Car : 0.8-0.9		
		FE	∅ 14.0	19.0	Gasket	Hex 16.0			4						
I	Double iridium spark plug	G	∅ 14.0	19.0	Gasket	Hex 20.8			5				-7	0.7	
L	Long thread reach plug	J	∅ 12.0	19.0	Gasket	Hex 18.0			6				-9	0.9	
P	Double platinum spark plug	K	∅ 12.0	19.0	Gasket	Hex 16.0			7			I	Iridium central electrode	-10	1.0
S	High ignitability plug : thin square tip type	KA	∅ 12.0	19.0	Gasket	Hex 14.0			8			IX	Iridium IX spark plug	-11	1.1
		KB	∅ 12.0	19.0	Gasket	Bi-Hex 14.0 (Bi-hexagonal *)			9			P	Platinum central electrode	-13	1.3
Z	Projected firing end								10					-15	1.5
Above alphabets are occasionally used in combination <Example>ILFR..., PLZFR..., When „L“ is included, priority is given to „L“ (long reach) in thread length. <Example> *Gasket type FR5AP : Thread length 19.0mm ↓ LFR5AP-11 : Thread length 26.5mm *Tapered seat type PTR5C-13 : Thread length 17.5mm ↓ PLTR6A-10G : Thread length 25.0mm		KE	∅ 12.0	19.0	Gasket	Hex 16.0								-A	Non gasket
		KF	∅ 12.0	19.0	Gasket	Hex 14.0								-D	Metal shell : nickel plating
		KG	∅ 12.0	19.0	Gasket	Bi-Hex 14.0 (Bi-hexagonal *)							-E	Special resistance	
		L	∅ 10.0	12.7	Gasket	Hex 16.0							-G	Copper cored ground electrode	
		M	∅ 10.0	19.0	Gasket	Hex 16.0							-H	Special thread shape	
		MA	∅ 10.0	19.0	Gasket	Hex 14.0							-J	2 ground-electrode	
		MF	∅ 10.0	19.0	Gasket	Hex 14.0							-K	Vibration-resistance ground electrode	
		NA	∅ 12.0	17.5	Tapered seat	Hex 14.0							-N	Special ground electrode	
		T	∅ 14.0	17.5	Tapered seat	Hex 16.0							-Q	4-ground-electrode	
		U	∅ 14.0	11.2	Tapered seat	Hex 16.0							-S	Special gasket	
		W	∅ 18.0	10.9	Tapered seat	Hex 20.8							-T	3-ground-electrode	
		X	∅ 14.0	9.5	Gasket	Hex 20.8							-U	Semi-surface discharge type	
		Y	∅ 14.0	11.2	Tapered seat	Hex 16.0							IX-P	Iridium MAX plug	
													LPG 1-8	LaserLine spark plugs range for gas engines	

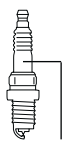

RE		7		C				-L	
Plug type		Heat rating		Design				Spark gap	
RE	Plug for rotary engines	5		A,B,C--Suffix code				-L	Leading position
SD	Plug for rotary engines (Semi-surface discharge gap)	6						-T	Trading position
		7							
		8							
		9							
		10							
		11							

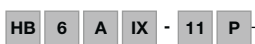
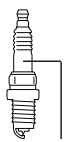

HB		6		A				IX		-11		P	
Plug type		Heat rating		Thread diameter	Thread length	Seat configuration	Hex size			Spark gap			
HB	HYBD (3-ground-electrode hybrid type)	4		A	∅ 14.0	20.5	Gasket	Hex 16.0	IX	-8	0.8		
		5		B	∅ 14.0	19.0	Gasket	Hex 16.0		-9	0.9		
		6								-10	1.0		
		7								-11	1.1		
		8							-13	1.3			

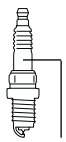

DF		6		H				-11		A	
Plug type		Heat rating		Thread diameter	Thread length	Seat configuration	Hex size	Spark gap			
DF	High ignitability plug (Double fine electrodes)	4		A	∅ 14.0	19.0	Gasket	Hex 16.0	-8	0.8	A,B,C... Suffix code
		5		B	∅ 14.0	26.5	Gasket	Hex 16.0	-9	0.9	
DFH	High ignitability plug (DF + Hybrid type)	6		C	∅ 12.0	26.5	Gasket	Hex 14.0	-10	1.0	
		7		*DF6H-11A : Thread length 28.0mm				-11	1.1		
		8						-13	1.3		
		9					-15	1.5			

So lesen Sie unsere Teilenummer: Zündkerzen

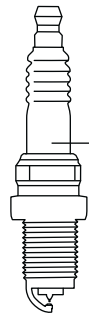

B P R 5 E S - 11

Einheit: mm

B		P		R		5		E		S		-11		
Gewinde-durchmesser	Sechskant	Struktur	Entstörwiderstand	Wärmewert	Gewindelänge	Konstruktionsmerkmale		Elektrodenabstand						
A	∅ 18,0	Hex 25,4	P vorgeschobene Isolatorspitze	R Widerstand	2	<p>warme Type</p> <p>kalte Type</p>	E 19,0	B feste SAE-Anschlussmutter (CR8EB)	leer	Motorrad : 0,7~0,8				
B	∅ 14,0	Hex 20,8	M Kompaktkerze	Z induktiver Widerstand	4		EF 17,5	CM Schräge Masseelektrode Kompaktbauart (Freiliegende Isolatorlänge: 18,5)		Auto : 0,8~0,9				
BC	∅ 14,0	Hex 16,0	U Gleitfunktentyp oder Zusatzfunktentrecke		5		EH 19,0 zur Hälfte ausgeführt	CS Schräge Masseelektrode	-8	0,8				
BK	∅ 14,0	Hex 16,0			6		H 12,7	G,GV Rennzündkerze	-9	0,9				
C	∅ 10,0	Hex 16,0			7		L 11,2	I Mittelelektrode, Iridium	-10	1,0				
D	∅ 12,0	Hex 18,0			8		leer	IX Iridium-Zündkerze	-11	1,1				
DC	∅ 12,0	Hex 16,0			9		Kegeldichtsitze A(P)-F : 10,9 B(P)-F : 11,2 BM(P)-F : 7,8 Zündkerze, klein B(P)M- : 9,5 B-LM : 9,5 CM- : 9,5 CM-6 : 8,6 C-50 : 8,5	J 2 überstehende Masseelektroden	-13	1,3				
E	∅ 8,0	Hex 13,0			10			K 2 Masseelektroden	-15	1,5				
*Ausnahme B(P)M-A,Y : ∅ 14,0, Hex 19,0 P(P)-(E)F : ∅ 14,0, Hex 16,0 CM-6 : ∅ 10,0, Hex 14,0		BC : Alte JIS-Standardgröße Die Länge zwischen dem Dichtungsring und der Anschlussklemme beträgt 53,0 mm.							-LM	Kompakt-Type (Isolatorlänge: 14,5)	-S	spezieller Dichting		
BK : ISO-/JIS-Standardgröße Die Länge zwischen dem Dichtungsring und der Anschlussklemme beträgt 50,5 mm.									N	spezielle Masse-Elektrode	-E	spezieller Widerstand		
								P	Platinelektrode Einzel-Masseelektrode: Mehrfach-Masseelektrode Doppelplatin: Einzelplatin in Mittelelektrode	IX-P	Iridium MAX Kerze	LPG 1-8	LaserLine-Zündkerzenserie für gasbetriebene Motoren	
								Q	4 Masseelektroden					
								S	Standard Type					
								T	3 Masseelektroden					
								U	Halbleitfunktentyp					
								Y	Mittelelektrode mit V-Einkerbung					
								Z	spezielle Konstruktion					



So lesen Sie unsere Teilenummer: Zündkerzen

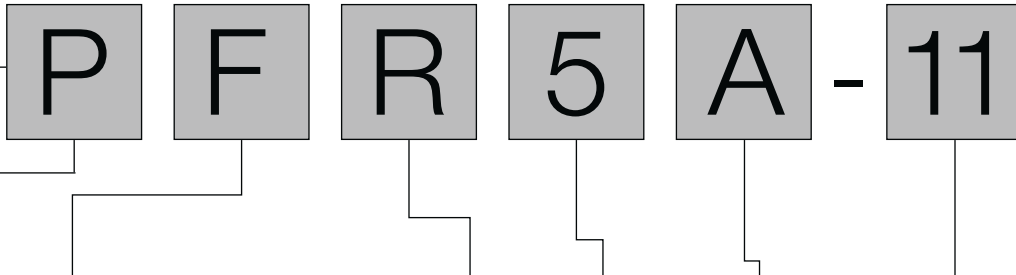
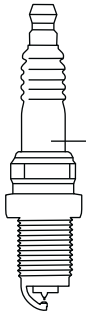

Einheit: mm

P		F				R		5		A		-11	
Zündkerzentyp		Gewinde-durchmesser	Gewinde-länge	Sitz-konstruktion	Sechskant	Entstörwiderstand		Wärmewert		Konstruktion		Elektrodenabstand	
DI	besonders hohe Zündfähigkeit, doppelt ausgeführte, feine Elektroden	F	∅ 14,0	19,0	Dichtring	Hex 16,0	R	Widerstand	2	warme Type kalte Type	A,B,C... Suffix code	leer	Motorrad : 0,7-0,8 Auto : 0,8-0,9
I	Zündkerze, Doppeliridium	FE	∅ 14,0	19,0	Dichtring	Hex 16,0			4				
L	besonders langes Gewinde	G	∅ 14,0	19,0	Dichtring	Hex 20,8			5				
P	Zündkerze, Doppelplatin	J	∅ 12,0	19,0	Dichtring	Hex 18,0			6				
S	Zündkerze mit hoher Zündwilligkeit: dünn, mit quadratischer Spitze	K	∅ 12,0	19,0	Dichtring	Hex 16,0			7				
Z	Vorgezogene Funkenlage	KA	∅ 12,0	19,0	Dichtring	Hex 14,0			8				
Oben angeführte Kennzeichen können kombiniert auftreten <Beispiel>ILFR..., PLZFR... Ist „L“ in der Markierung enthalten, erhält „L“ (lange Gewindelänge)“ Priorität bei der Gewindelänge. <Beispiel> * Kerze mit Dichtring FR5AP : Gewindelänge 19,0mm ↓ LFR5AP-11 : Gewindelänge 26,5mm * Kerze mit Kegeldichtring PTR5C-13 : Gewindelänge 17,5mm ↓ PLTR6A-10G : Gewindelänge 25,0mm	KE	∅ 12,0	19,0	Dichtring	Hex 16,0	9							
	KF	∅ 12,0	19,0	Dichtring	Hex 14,0	10							
	KG	∅ 12,0	19,0	Dichtring	Bi-Hex 14,0 (Doppelsechskant *)								
	L	∅ 10,0	12,7	Dichtring	Hex 16,0								
	M	∅ 10,0	19,0	Dichtring	Hex 16,0								
	MA	∅ 10,0	19,0	Dichtring	Hex 14,0								
	MF	∅ 10,0	19,0	Dichtring	Hex 14,0								
	NA	∅ 12,0	17,5	Kegeldichtring	Hex 14,0								
	T	∅ 14,0	17,5	Kegeldichtring	Hex 16,0								
	U	∅ 14,0	11,2	Kegeldichtring	Hex 16,0								
W	∅ 18,0	10,9	Kegeldichtring	Hex 20,8									
X	∅ 14,0	9,5	Dichtring	Hex 20,8									
Y	∅ 14,0	11,2	Kegeldichtring	Hex 16,0									
* Ausnahme TR5A-10, TR5A-13, TR5B-13, TR6B-10, TR6B-13, PTR5A-10, PTR5A-13: Gewindelänge 25,0 mm * Doppel-Innensechskant erforderlich. * FFE, KE, KF, KG, MF: Bauart mit längerem freiliegenden Isolator					Doppelsechskant Sechskant 		* Wenn am Anfang der Teilenummer „I“ oder „P“ steht („I“ oder „P“ nach dem Temperaturwert wird zum nachgestellten Zusatzcode.) <Beispiel> IZFR6P8 bedeutet Iridium-Zündkerze I: Iridium P: Zusatzcode * <Ausnahme> ZFR0P-G bedeutet Nickel-Zündkerze		-A kein Dichtring -D Metallhülse: Nickel-beschichtet -E spezieller Widerstand -G Masselektrode mit Kupferkern -H spezielles Gewinde -J 2 Massen-Elektroden -K schwingungsfeste Masselektrode -N spezielle Massen-Elektrode -Q 4 Massen-Elektrode -S spezieller Dichtring -T 3 Massen-Elektrode -U Halbgleitfunkentyp IX-P Iridium MAX Kerze LPG 1-8 LaserLine-Zündkerzenserie für gasbetriebene Motoren				

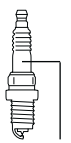

RE		7		C		-L	
Zündkerzentyp		Wärmewert		Konstruktion		Elektrodenabstand	
RE	Zündkerze für Wankelmotor	5	warme Type kalte Type	A,B,C... Suffix code		-L	oberer Totpunkt
SD	Zündkerze für Wankelmotor (Halbgleitfunkentyp)	6					
		7					
		8					
		9					
		10					
		11					

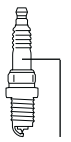

HB		6		A		IX		-11		P	
Zündkerzentyp		Wärmewert		Gewinde-durchmesser	Gewinde-länge	Sitzkonstruktion	Sechskant	Elektrodenabstand			
HB	HYBD (3 Masselektroden, Hybridbauart)	4	warme Type kalte Type	A	∅ 14,0	20,5	Dichtring	Hex 16,0	IX	-8	0,8
		5		B	∅ 14,0	19,0	Dichtring	Hex 16,0		-9	0,9
		6								-10	1,0
		7								-11	1,1
		8								-13	1,3

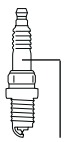

DF		6		H		-11		A		
Zündkerzentyp		Wärmewert		Gewinde-durchmesser	Gewinde-länge	Sitzkonstruktion	Sechskant	Elektrodenabstand		
DF	Zündkerze mit hoher Zündwilligkeit (Doppel-Elektrode, dünn)	4	warme Type kalte Type	A	∅ 14,0	19,0	Dichtring	Hex 16,0	-8	0,8
DFH	Zündkerze mit hoher Zündwilligkeit (DF + Hybrid)	5		B	∅ 14,0	26,5	Dichtring	Hex 16,0	-9	0,9
		6		C	∅ 12,0	26,5	Dichtring	Hex 14,0	-10	1,0
		7		* DF6H-11A : Gewindelänge 28,0mm					-11	1,1
		8							-13	1,3
		9							-15	1,5

Comment lire notre numéro de pièce: Bougies

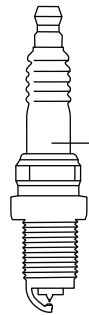

B P R 5 E S - 11

Unité : mm

B		P		R		5		E		S		-11			
	Diamètre de filetage	Hexagone	Structure		Résistance antiparasitage		Indice thermique		Longueur du filetage		Caractéristiques de conception		Ecartement		
A	∅ 18,0	Hex 25,4	P	Isolant proéminent	R	Résistance	2	 Type chaud Type froid	E	19,0	B	Olive SAE monbloque (CR8EB)		vide	Moto : 0,7~0,8 Automobile : 0,8~0,9
B	∅ 14,0	Hex 20,8			Z	Inductance intégrée	4		EF	17,5		CM	Électrode de masse inclinée Type compact (Longueur d'isolant exposé : 18,5)		
BC	∅ 14,0	Hex 16,0	M	Bougie compacte		5	EH		19,0 semi-filetage Culot 19 mm Filetage 12,7	CS	Électrode de masse inclinée		-8	0,8	
BK	∅ 14,0	Hex 16,0				6	H		12,7		G,GV	Bougie d'allumage de course		-9	0,9
C	∅ 10,0	Hex 16,0	U	Décharge superficielle ou à étincelle semi-surfacique		7	L		11,2	I		Électrode centrale en iridium		-10	1,0
D	∅ 12,0	Hex 18,0				8	IX		Gamme Iridium IX		-11	1,1			
DC	∅ 12,0	Hex 16,0				9			J	2 électrodes de masse à projection		-13	1,3		
E	∅ 8,0	Hex 13,0				10	K			2 électrodes de masse		-15	1,5		
* Exception B(P)M-A,Y : ∅ 14,0, Hex 19,0 P(P)-(E)F : ∅ 14,0, Hex 16,0 CM-6 : ∅ 10,0, Hex 14,0		BC : Ancienne taille standard JIS La longueur entre le circuit du joint et le contact de la borne est de 53 mm.				BK : Taille standard ISO/JIS La longueur entre le circuit du joint et le contact de la borne est de 50,5 mm.			vide		Siège conique A(P)-F : 10,9 B(P)-F : 11,2 BM(P)-F : 7,8		-LM		Type compact (longueur isolant : 14,5 mm)
						Bougie de petite taille B(P)M- : 9,5 B-LM : 9,5 CM- : 9,5 CM-6 : 8,6 C-50 : 8,5			N		Electrode de masse spéciale		-S	Joint spécifique	
								P		Electrode centrale en Platine Electrode de masse simple : Double platine Electrode à masses multiples : Platine simple dans l'électrode centrale		-E	Résistance spéciale		
								Q		4 électrodes de masse		IX-P	Bougie Iridium MAX		
								S		Electrode centrale en cuivre			LPG 1-8	Gamme de bougies d'allumage LaserLine pour utilisation sur moteur à gaz	
								T		3 électrodes de masse					
								U		à décharge semi-surfacique					
								Y		Electrode centrale à gorge en V - Proéminence sup. à 1mm					
								Z		Conception spéciale					



Come leggere il nostro numero del pezzo: Candele di accensione

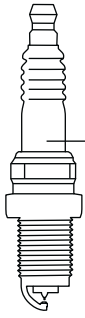

B P R 5 E S - 11

Unità: mm

B		P		R		5		E		S		-11				
	Diametro filettatura	esagono	Struttura		Resistore		Grado termico		Lunghezza filettatura		Caratteristiche costruttive		Gap			
A	∅ 18,0	Hex 25,4	P	punta isolatore prominente	R	Candela resistiva	2	 candela calda	E	19,0	B	terminale SAE fisso (CR8EB)		leer	Motociclo : 0,7~0,8 Auto : 0,8~0,9	
B	∅ 14,0	Hex 20,8			Z	resistenza induttiva	4		EF	17,5		CM	Elettrodo inclinato di messa a terra Tipo compatto (lunghezza isolante visibile: 18,5)			
BC	∅ 14,0	Hex 16,0	M	Candela compatta del tipo Bantam		5	EH		19,0 parzialmente filettata		CS		Elettrodo inclinato di messa a terra		-8	0,8
BK	∅ 14,0	Hex 16,0				U			Candela a scarica superficiale o semisuperficiale	6		H	12,7		G,GV	Candela Racing
C	∅ 10,0	Hex 16,0	7	L	11,2		vuoto			Sede conica A(P)-F : 10,9 B(P)-F : 11,2 BM(P)-F : 7,8			I	Elettrodo centrale in iridio		-10
D	∅ 12,0	Hex 18,0	8		Candela del tipo piccolo B(P)M- : 9,5 B-LM- : 9,5 CM-6 : 8,6 C-50 : 8,5	9			IX	Candela Iridium IX		J		2 elettrodi di messa a terra prominenti		-11
DC	∅ 12,0	Hex 16,0	10	candela fredda			K			2 elettrodi di messa a terra			LM	Tipi compatti (lunghezza isolatore: 14,5)		-S
E	∅ 8,0	Hex 13,0												P	elettrodo al platino Elettrodo di messa a terra singolo: Platino doppio	
* Eccezione B(P)M-A,Y : ∅ 14,0, Hex 19,0 P(P)-(E)F : ∅ 14,0, Hex 16,0 CM-6 : ∅ 10,0, Hex 14,0													IX-P		Candela all'Iridio MAX	
BC : Misura standard JIS precedente La lunghezza dalla guarnizione del circuito al terminale è di 53 mm.														LPG 1-8	Gamma di candele LaserLine per motori a gas	
BK : Misura standard ISO / JIS La lunghezza dalla guarnizione del circuito al terminale è di 50,5 mm.																
														Q		
													S		Tipo standard	
														T	3 elettrodi di messa a terra	
													U		Tipo a scarica semi-superficiale	
														Y	Elettrodo centrale scanalato a V - V grooved -	
													Z		struttura speciale	



Come leggere il nostro numero del pezzo: Candele di accensione

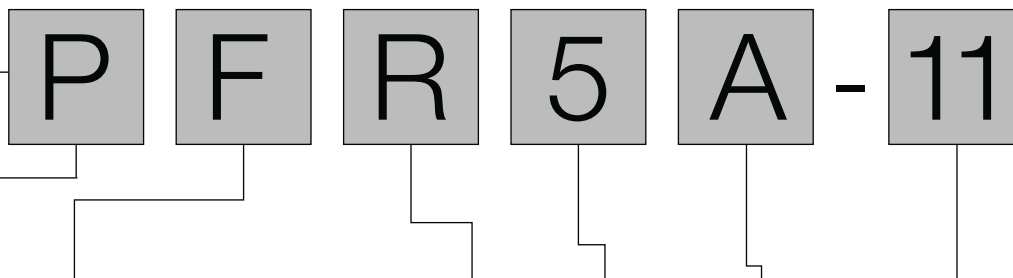
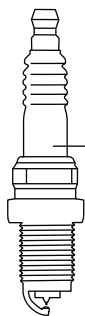

Unità: mm

P		F				R		5		A		-11			
Tipo candela		Diametro filettatura	Lunghezza filettatura	Configurazione della sede	esagono	Resistore		Grado termico		Costruzione		Gap			
DI	candela ad elevatissima accendibilità tipo DFE (Double Fine electrodes)	F	∅ 14,0	19,0	Guarnizione anulare	Hex 16,0	R	Resistenza	2	<p>candela calda</p> <p>candela fredda</p>	A,B,C... Suffix code	vuoto	Motociclo: 0,7-0,8 Auto : 0,8-0,9		
		FE	∅ 14,0	19,0	Guarnizione anulare	Hex 16,0			4						
I	Candele al doppio iridio	G	∅ 14,0	19,0	Guarnizione anulare	Hex 20,8			5				-7	0,7	
L	candela a filettatura estesa	J	∅ 12,0	19,0	Guarnizione anulare	Hex 18,0			6				-9	0,9	
P	Candele al doppio platino	K	∅ 12,0	19,0	Guarnizione anulare	Hex 16,0			7			I	Elettrodo centrale in iridio	-10	1,0
S	Alta accendibilità della candela: punta del tipo sottile quadrangolare	KA	∅ 12,0	19,0	Guarnizione anulare	Hex 14,0			8			IX	Candela Iridium IX	-11	1,1
		KB	∅ 12,0	19,0	Guarnizione anulare	Bi-Hex 14,0 (Bi-esagonale *)			9			P	Elettrodo centrale in platino	-13	1,3
Z	Elettrodo prominente	KE	∅ 12,0	19,0	Guarnizione anulare	Hex 16,0			10					-15	1,5
I codici sopraindicati possono presentarsi in varie combinazioni, <Esempio>ILFR..., PLZFR..., Quando è inclusa una „L“, la priorità viene data alla „L“ (braccio lungo) per la lunghezza della filettatura.		KF	∅ 12,0	19,0	Guarnizione anulare	Hex 14,0						* Quando è presente una „I“ o una „P“ all'inizio del numero del pezzo („I“ o „P“ dopo il grado termico diventa il codice suffisso.)		-A	senza guarnizione anulare
<Esempio> *Candela con guarnizione anulare FR5AP : lunghezza filettatura 19,0mm LFR5AP-11 : lunghezza filettatura 26,5mm		KG	∅ 12,0	19,0	Guarnizione anulare	Bi-Hex 14,0 (Esagonale *)						<Esempio> IZFR6P8 è una candela all'iridio I: Iridio P: Codice suffisso * <Eccezione> ZFR0P-G è una candela al nichel		-D	Supporto in metallo: nichelatura
*Candela con sede conica PTR5C-13 : lunghezza filettatura 17,5mm PLTR6A-10G : lunghezza filettatura 25,0mm		L	∅ 10,0	12,7	Guarnizione anulare	Hex 16,0						-E	resistenza speciale		
		M	∅ 10,0	19,0	Guarnizione anulare	Hex 16,0						-G	Elettrodo di terra con nucleo in rame		
		MA	∅ 10,0	19,0	Guarnizione anulare	Hex 14,0						-H	Filettatura speciale		
		MF	∅ 10,0	19,0	Guarnizione anulare	Hex 14,0						-J	2 elettrodi di massa		
		NA	∅ 12,0	17,5	Sede conica	Hex 14,0						-K	Elettrodo di terra resistente alle vibrazioni		
		T	∅ 14,0	17,5	Sede conica	Hex 16,0						-N	Elettrodo di massa speciale		
		U	∅ 14,0	11,2	Sede conica	Hex 16,0						-Q	4 elettrodi di massa		
		W	∅ 18,0	10,9	Sede conica	Hex 20,8						-S	Guarnizione anulare speciale		
		X	∅ 14,0	9,5	Guarnizione anulare	Hex 20,8						-T	3 elettrodi di massa		
		Y	∅ 14,0	11,2	Sede conica	Hex 16,0						-U	Tipo a scarica semi-superficiale		
		* Fatta eccezione per TR5A-10, TR5A-13, TR5B-13, TR6B-10, TR6B-13, PTR5A-10, PTR5A-13: Lunghezza della filettatura 25,0mm				Bi-esagonale						IX-P	Candela all'iridio MAX		
		* È necessario un attacco bi-esagonale.				Esagonale						LPG 1-8	Gamma di candele LaserLine per motori a gas		
		* FE, KE, KF, KG, MF: Tipo con isolante visibile più lungo													

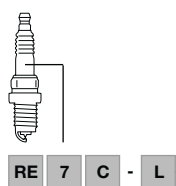

RE		7		C		-L	
Tipo candela		Grado termico		Costruzione		Gap	
RE	Candela per motori rotativi	5	<p>candela calda</p> <p>candela fredda</p>	A,B,C... Suffix code		-L	Leading side
SD	Candela per motori rotativi (distanza tra gli elettrodi a scarica semi-superficiale)	6				-T	Trading side
		7					
		8					
		9					
		10					
		11					

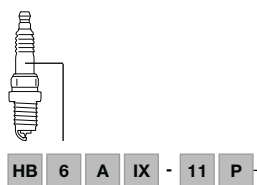

HB		6		A				IX		-11		P		
Tipo candela		Grado termico		Diametro filettatura	Lunghezza filettatura	Configurazione della sede	esagono	Costruzione		Gap				
HB	HYBD (tipo ibrido con 3 elettrodi di messa a terra)	4	<p>candela calda</p> <p>candela fredda</p>	A	∅ 14,0	20,5	Guarnizione anulare	Hex 16,0	IX	-8	0,8			
		5			B	∅ 14,0	19,0	Guarnizione anulare	Hex 16,0		-9	0,9		
		6									-10	1,0		
		7									-11	1,1		
		8									-13	1,3		

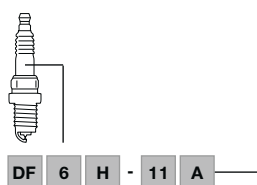

DF		6		H				-11		A				
Tipo candela		Grado termico		Diametro filettatura	Lunghezza filettatura	Configurazione della sede	esagono	Costruzione		Gap				
DF	Candela ad alta accendibilità (elettrodi sottili doppi)	4	<p>candela calda</p> <p>candela fredda</p>	A	∅ 14,0	19,0	Guarnizione anulare	Hex 16,0		-8	0,8	A,B,C... Suffix code		
		5			B	∅ 14,0	26,5	Guarnizione anulare	Hex 16,0		-9	0,9		
DFH	Candela ad alta accendibilità (DF + tipo ibrido)	6			C	∅ 12,0	26,5	Guarnizione anulare	Hex 14,0		-10	1,0		
		7			*DF6H-11A : Lunghezza filettatura 28,0mm						-11	1,1		
		8									-13	1,3		
		9									-15	1,5		

Cómo leer nuestros números de pieza: Bujías

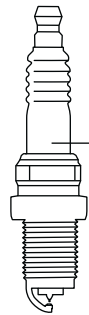

B P R 5 E S - 11

Unidad: mm

B		P		R		5		E		S		-11		
	Diámetro de la rosca	Tamaño del Hexágono	Estructura		Construcción / Características		Grado térmico		Longitud de la rosca		Características constructivas		Galga (mm), Nada: Galga convencional	
A	∅ 18,0	Hex 25,4	P	Tipo aislador proyectado	R	Tipo Resistencia	2		E	19,0	B	Tuerca terminal SAE fija (CR8EB)	vacío	Motocicleta: 0,7 - 0,8 mm Automóvil: 0,8 - 0,9 mm
B	∅ 14,0	Hex 20,8			Z	Tipo Resistencia Inductiva	4		EF	17,5	CM	Electrodo de masa inclinado Tipo compacto (longitud de aislador expuesto: 18,5)		
BC	∅ 14,0	Hex 16,0	M	Tipo Compacto (Bantam)		5	EH		Media rosca, Total: 19,00 mm, Rosca I: 12,7 mm	CS	Electrodo de masa inclinado	-8	0,8	
BK	∅ 14,0	Hex 16,0				6	H		12,7	G,GV	Bujía de competición	-9	0,9	
C	∅ 10,0	Hex 16,0	U	Tipo descarga superficial o semi-superficial		7	L		11,2	I	Electrodo central de iridio	-10	1,0	
D	∅ 12,0	Hex 18,0				8	vacío Asiento cónico A(P)-F : 10,9 B(P)-F : 11,2 BM(P)-F : 7,8 Bujía de tipo pequeño B(P)M- : 9,5 B-LM : 9,5 CM- : 9,5 CM-6 : 8,6 C-50 : 8,5		9	IX	Electrodo de iridio IX	-11	1,1	
DC	∅ 12,0	Hex 16,0	10	J		2 electrodos de masa prominentes			-13	1,3				
E	∅ 8,0	Hex 13,0	*Excepción B(P)M-A,Y : ∅ 14,0, Hex 19,0 P(P)-(E)F : ∅ 14,0, Hex 16,0 CM-6 : ∅ 10,0, Hex 14,0 BC : Altura JIS estándar antigua La longitud desde el asiento a la parte superior del terminal es de 53,0 mm. BK : Altura estándar ISO/JIS La longitud desde el asiento a la parte superior del terminal es de 50,5 mm.	K		2 electrodos de masa			-15	1,5				
				-LM		Tipo compacto (longitud del aislante: 14,5 mm)								
				N		Electrodo especial de masa								
				P		Electrodo de platino Un solo electrodo de masa: doble platino Varios electrodos de masa: platino sencillo en el electrodo central								
				Q		4 electrodos de masa								
				S	Tipo estándar									
				T	3 electrodos de masa									
				U	Tipo descarga semi superficial									
				Y	Electrodo central con ranurado en V									
				Z	Fabricación especial									

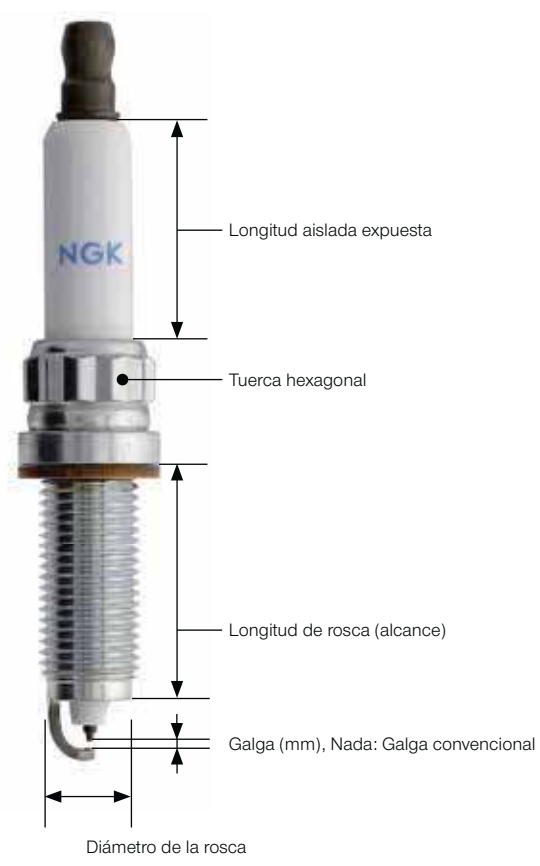

Cómo leer nuestros números de pieza: Bujías

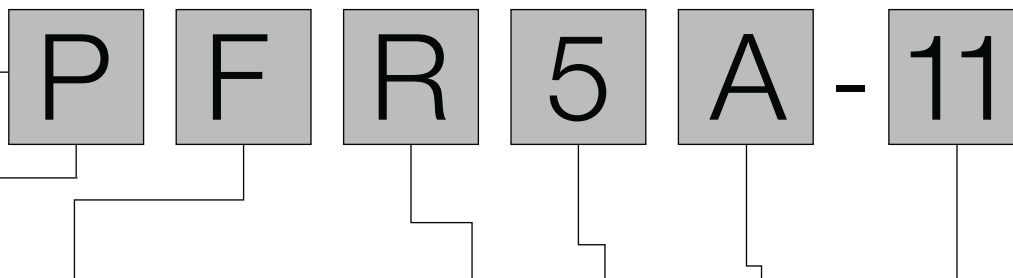
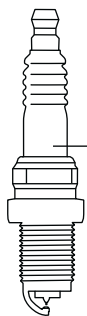

Unidad: mm

P		F				R		5		A		-11			
Tipo de bujía		Diámetro de la rosca	longitud de rosca	Configuración de asiento	Tamaño del Hexágono	Resistencia		Grado térmico		Construcción		Galga (mm), Nada: Galga convencional			
DI	Gran apacidad de inflamación: electrodo extra fino	F	∅ 14,0	19,0	Con Junta	Hex 16,0	R	Resistencia	2		A,B,C... Código de sufijo	vacio	Motocicleta: 0,7-0,8 Automóvil: 0,8-0,9		
I	Bujía de doble iridio	FE	∅ 14,0	19,0	Con Junta	Hex 16,0			4				-7	0,7	
L	Rosca extralarga	G	∅ 14,0	19,0	Con Junta	Hex 20,8			5				-9	0,9	
P	Bujía de doble platino	J	∅ 12,0	19,0	Con Junta	Hex 18,0			6				-10	1,0	
S	Bujía de alta inflamabilidad: tipo de punta cuadrada fina	K	∅ 12,0	19,0	Con Junta	Hex 16,0			7			I	Electrodo central de iridio	-11	1,1
Z	Extremo de encendido protuberante	KA	∅ 12,0	19,0	Con Junta	Hex 14,0			8			IX	Electrodo de iridio IX	-13	1,3
		KB	∅ 12,0	19,0	Con Junta	Bi-Hex 14,0 (Bi-hexagonal *)			9			P	Electrodo central de platino	-15	1,5
		KE	∅ 12,0	19,0	Con Junta	Hex 16,0			10						
		KF	∅ 12,0	19,0	Con Junta	Hex 14,0									
		KG	∅ 12,0	19,0	Con Junta	Hex 14,0 (Bi-hexagonal *)									
		L	∅ 10,0	12,7	Con Junta	Hex 16,0									
		M	∅ 10,0	19,0	Con Junta	Hex 16,0									
		MA	∅ 10,0	19,0	Con Junta	Hex 14,0									
		MF	∅ 10,0	19,0	Con Junta	Hex 14,0									
		NA	∅ 12,0	17,5	Asiento cónico	Hex 14,0									
		T	∅ 14,0	17,5	Asiento cónico	Hex 16,0									
		U	∅ 14,0	11,2	Asiento cónico	Hex 16,0									
		W	∅ 18,0	10,9	Asiento cónico	Hex 20,8									
		X	∅ 14,0	9,5	Dichtring	Hex 20,8									
		Y	∅ 14,0	11,2	Asiento cónico	Hex 16,0									

Las características arriba nombrada pueden aparecer combinadas, <Ejemplo>ILFR..., PLZFR...
 Cuando se incluye „L“, se da prioridad a „L“ (alcance largo) en longitud de rosca.
 <Ejemplo>
 *Bujía con junta
 FR5AP-11; longitud de rosca 19,0 mm
 ↓
 LFR5AP-11; longitud de rosca 26,5mm
 *Bujía con asiento cónico
 PTR5C-13; longitud de rosca 17,5 mm
 ↓
 PLTR6A-10G; longitud de rosca 25,0 mm

* Excepción TR5A-10, TR5A-13, TR5B-13, TR6B-10, TR6B-13, PTR5A-10, PTR5A-13: Longitud de la rosca 25,0 mm
 * Se necesita una llave de vaso bihexagonal.
 * FE, KE, KF, KG, MF: Tipo de longitud de aislador expuesto mayor

RE		7		C		-L	
Tipo de bujía		Grado térmico		Construcción		Galga (mm), Nada: Galga convencional	
RE	Bujía para motores rotativos	5		A,B,C... Código de sufijo		-L	Lado avanzado
SD	Bujía para motores rotativos (separación entre electrodos de descarga semi-superficial)	6				-T	Lado retrasado
		7					
		8					
		9					
		10					
		11					

HB		6		A		IX		-11		P	
Tipo de bujía		Grado térmico		Diámetro de la rosca	longitud de rosca	Configuración de asiento	Tamaño del Hexágono	Galga (mm), Nada: Galga convencional			
HB	HYBD (3 electrodos de masa tipo híbrido)	4		A	∅ 14,0	20,5	Con Junta	Hex 16,0	IX	-8	0,8
		5		B	∅ 14,0	19,0	Con Junta	Hex 16,0		-9	0,9
		6								-10	1,0
		7								-11	1,1
		8								-13	1,3

DF		6		H		-11		A		
Tipo de bujía		Grado térmico		Diámetro de la rosca	longitud de rosca	Configuración de asiento	Tamaño del Hexágono	Galga (mm), Nada: Galga convencional		
DF	Bujía de alta inflamabilidad (electrodos finos dobles)	4		A	∅ 14,0	19,0	Con Junta	Hex 16,0	-8	0,8
		5		B	∅ 14,0	26,5	Con Junta	Hex 16,0	-9	0,9
DFH	Bujía de alta inflamabilidad (DF + tipo híbrido)	6		C	∅ 12,0	26,5	Con Junta	Hex 14,0	-10	1,0
		7		*DF6H-11A : Longitud de la rosca 28,0 mm					-11	1,1
		8							-13	1,3
		9						-15	1,5	

Hoe moet ons onderdeelnummer worden gelezen: Bougies

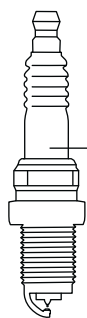

Eenheid: mm

B		P		R		5		E		S		-11			
Schroefdraaddiameter	Zeskant	Structuur		Ontstoringweerstand		Warmtewaarde		Schroefdraadlengte		Constructiekenmerken		Elektrodeafstand			
A	∅ 18,0	Hex 25,4	P	Verschuiven isolatorpunt	R	Weerstand	2		E	19,0	B	aste SAE-aansluitmoer (CR8EB)	Leeg	Motorrijwiel : 0,7~0,8	
B	∅ 14,0	Hex 20,8	Z	Inductieve weerstand	4	EF	17,5		CM	Schuine massa-elektrode Compact type (Onbeschermd isolatorlengte: 18,5)	Auto : 0,8~0,9				
BC	∅ 14,0	Hex 16,0	M	Compacte bougie	5	EH	19,0 voor de helft uitgevoerd		CS	Schuine massa-elektrode	-8	0,8			
BK	∅ 14,0	Hex 16,0	U	Glijvonk-type of extra vonktraject	6	H	12,7		G,GV	Racebougie	-9	0,9			
C	∅ 10,0	Hex 16,0			7	L	11,2		I	Middenelektrode van iridium	-10	1,0			
D	∅ 12,0	Hex 18,0			8	IX	Iridium bougie		-11	1,1					
DC	∅ 12,0	Hex 16,0			9	J	2-projecterende-massa-elektrodes		-13	1,3					
E	∅ 8,0	Hex 13,0			10	K	2-massa-elektrodes		-15	1,5					
*Uitzondering B(P)M-A,Y : ∅ 14,0, Hex 19,0 P(P)-(E)F : ∅ 14,0, Hex 16,0 CM-6 : ∅ 10,0, Hex 14,0									Leeg						
BC : Oude JIS-standaardgrootte De lengte van pakkingcircuit naar eindcontact bedraagt 53,0 mm.									Kleine bougie A(P)-F : 10,9 B(P)-F : 11,2 BM(P)-F : 7,8						
BK : ISO / JIS standaardgrootte De lengte van pakkingcircuit naar eindcontact bedraagt 50,5 mm.								N		Speciale massa-elektrode		-S		Speciale dichtring	
								P		Platina elektrode Enkele massa-elektrode Meerdere massa-elektrodes van dubbel platina: Enkel platina in middenelektrode		-E		Speciale weerstand	
										Q		4-massa-elektrodes		-IX-P	Iridium MAX-bougie
										S		Standaard type		LPG 1-8	LaserLine bougieassortiment voor gebruik in gasmotoren
										T		3-massa-elektrodes			
										U		Type halfglijvonk			
										Y		Middenelektrode met V-inkepin			
										Z		Speciale constructie			



Hoe moet ons onderdeelnummer worden gelezen: Bougies

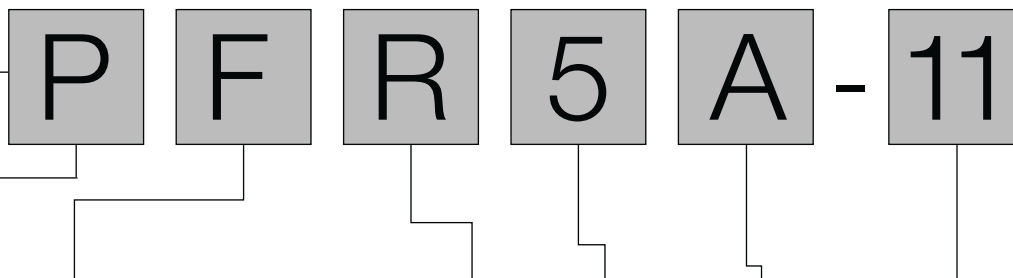
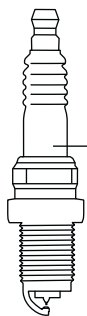

Eenheid: mm

P		F				R	5		A		-11				
Bougie Type		Schroefdraad-diameter	Schroef-draadlengte	Zitting-configuratie	Zeskant	Ontstortingsweer-stand	Warmtewaarde		Constructie		Elektrodeafstand				
DI	Extremе ontbrandbaarheid, dubbel uitgevoerde, fijne elektroden	F	∅ 14,0	19,0	Dichtring	Hex 16,0	R	Résistance	2		A,B,C... Suffix code	leer	Motorrijwiel : 0,7-0,8		
		FE	∅ 14,0	19,0	Dichtring	Hex 16,0			4				Auto : 0,8-0,9		
I	Dubbel iridium bougie	G	∅ 14,0	19,0	Dichtring	Hex 20,8			5				-7	0,7	
L	Bijzonder lange schroefdraad 26,5mm	J	∅ 12,0	19,0	Dichtring	Hex 18,0			6				-9	0,9	
P	Dubbel platina bougie	K	∅ 12,0	19,0	Dichtring	Hex 16,0			7			I	Middenelektrode van iridium	-10	1,0
S	Hoog ontvlambare bougie: type dun vierkant uiteinde	KA	∅ 12,0	19,0	Dichtring	Hex 14,0			8			IX	Iridium bougie	-11	1,1
Z	Uitstekende elektrode	KB	∅ 12,0	19,0	Conische zitting	Bi-Hex 14,0 (Dubbele zeskant *)			9			P	Middenelektrode van platina	-13	1,3
		KE	∅ 12,0	19,0	Dichtring	Hex 16,0			10					-15	1,5
		KF	∅ 12,0	19,0	Dichtring	Hex 14,0									
		KG	∅ 12,0	19,0	Dichtring	Bi-Hex 14,0 (Dubbele zeskant *)									
		L	∅ 10,0	12,7	Dichtring	Hex 16,0									
		M	∅ 10,0	19,0	Dichtring	Hex 16,0									
		MA	∅ 10,0	19,0	Dichtring	Hex 14,0									
		MF	∅ 10,0	19,0	Dichtring	Hex 14,0									
		NA	∅ 12,0	17,5	Conische zitting	Hex 14,0									
		T	∅ 14,0	17,5	Conische zitting	Hex 16,0									
		U	∅ 14,0	11,2	Conische zitting	Hex 16,0									
		W	∅ 18,0	10,9	Conische zitting	Hex 20,8									
		X	∅ 14,0	9,5	Dichtring	Hex 20,8									
		Y	∅ 14,0	11,2	Conische zitting	Hex 16,0									
Hierboven genoemde kenmerken kunnen gecombineerd optreden, <Voorbeeld>ILFR..., PLZFR... Wanneer „L“ is inbegrepen, wordt in de draadlengte prioriteit aan „L“ (lang bereik) gegeven. <Voorbeeld> *Bougie met dichtring FR5AP : draadlengte 19,0mm ↓ LFR5AP-11 : draadlengte 26,5mm *Bougie met conische zitting PTR5C-13 : draadlengte 17,5mm ↓ PLTR6A-10G : draadlengte 25,0mm		* Uitzondering TR5A-10, TR5A-13, TR5B-13, TR6B-10, TR6B-13, PTR5A-10, PTR5A-13 : Draadlengte 25,0 mm * Dubbele zeskantdop is nodig. * FE, KE, KF, KG, MF: Type grotere onbeschermdе isolatorlengte		<p>Zeskant</p>				* Wanneer „I“ of „P“ aan het begin van het onderdeelnummer staat („I“ of „P“ na warmtegraad wordt suffixcode.) <Voorbeeld> IZFR6P8 is iridium bougie I: Iridium P: Suffixcode * <Uitzondering> ZFR6P-G is bougie van nikkel		-A Geen dichtring -D Metalen behuizing: vernikkeld -E Speciale weerstand -G Massa-elektrode met koperen kern -H Speciale schroefdraad -J 2 massa-elektroden -K Trilbestendige massa-elektrode -N Speciale massa-elektrode -Q 4 massa-elektroden -S Speciale dichtring -T 3 massa-elektroden -U Type halfglijvonkntsteking IX-P Iridium MAX-bougie LPG 1-8 LaserLine bougieassortiment voor gasmotoren					

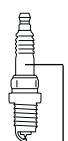

RE		7	C		-L		
Bougie Type		Warmtewaarde		Constructie		Elektrodeafstand	
RE	Bougie voor rotatiemotoren	5		A,B,C... Suffix code		-L	Geleidende zijde
SD	Bougie voor rotatiemotoren (Opening halfglijvonkntsteking)	6				-T	Uitwisselende zijde
		7					
		8					
		9					
		10					
		11					

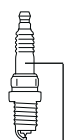

HB		6	A				IX	-11		P	
Bougie Type		Warmtewaarde		Schroefdraad-diameter	Schroefdraad-lengte	Zitting-configuratie	Zeskant	Elektrodeafstand			
HB	HYBD (3-massa-elektrode hybride type)	4		A	∅ 14,0	20,5	Joint	Hex 16,0	IX	-8	0,8
		5		B	∅ 14,0	19,0	Joint	Hex 16,0		-9	0,9
		6								-10	1,0
		7								-11	1,1
		8								-13	1,3

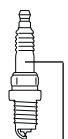

DF		6	H				-11		A	
Bougie Type		Warmtewaarde		Schroefdraad-diameter	Schroefdraad-lengte	Zitting-configuratie	Zeskant	Elektrodeafstand		
DF	Hoog ontvlambare bougie (Dubbele fijne elektrodes)	4		A	∅ 14,0	19,0	Joint	Hex 16,0	-8	0,8
		5		B	∅ 14,0	26,5	Joint	Hex 16,0	-9	0,9
DFH	Hoog ontvlambare bougie (DF + hybride type)	6		C	∅ 12,0	26,5	Joint	Hex 14,0	-10	1,0
		7		*DF6H-11A : Schroefdraadlengte 28,0 mm				-11	1,1	
		8						-13	1,3	
		9					-15	1,5		

Como ler o nosso número de peça: Velas de ignição

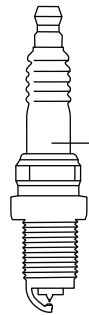

B P R 5 E S - 11

Unidade : mm

B		P		R		5		E		S		-11			
Tamanho da rosca	Tamanho do hexágono	Estrutura		Construçã		Número de potência térmica		Alcance da rosca		Características construtivas		Espaço da vela (mm)			
A	∅ 18,0	Hex 25,4	P	Isolador projetado	R	Resistência	2	<p>Mais quente</p> <p>Mais frio</p>	E	19,0	B	Porca SAE fixa (CR8EB)	Vazio	Mota: 0,7 - 0,8 mm	
B	∅ 14,0	Hex 20,8	M	Vela compacta (Bantam)	Z	Resistência indutiva	4		EF	17,5	CM	Eléctrodo de terra oblíquo Tipo compacto (Comprimento do isolador exposto: 18,5)		Carro: 0,8 - 0,9 mm	
BC	∅ 14,0	Hex 16,0	U	Descarga superficial ou semi-surface			5		EH	19,0 executado até à metade	CS	Eléctrodo de terra oblíquo	-8	0,8	
BK	∅ 14,0	Hex 16,0					6		H	12,7	G,GV	Vela de competição	-9	0,9	
C	∅ 10,0	Hex 16,0					7		L	11,2	I	Eléctrodo central de irídio	-10	1,0	
D	∅ 12,0	Hex 18,0					8		IX	Vela de irídio	-11	1,1			
DC	∅ 12,0	Hex 16,0					9		J	2 eléctrodos de terra projetores	-13	1,3			
E	∅ 8,0	Hex 13,0					10		K	2 eléctrodos de terra	-15	1,5			
*Exceção B(P)M-A,Y : ∅ 14,0, Hex 19,0 P(P)-(E)F : ∅ 14,0, Hex 16,0 CM-6 : ∅ 10,0, Hex 14,0		BC : Antigo JIS tamanho padrão O comprimento do circuito da junta ao contacto terminal é de 53,0 mm.							Vazio		Assento cónico A(P)-F : 10,9 B(P)-F : 11,2 BM(P)-F : 7,8				
		BK : ISO / JIS tamanho padrão O comprimento do circuito da junta ao contacto terminal é de 50,5mm.							Ficha de tipo pequeno B(P)M- : 9,5 B-LM : 9,5 CM- : 9,5 CM-6 : 8,6 C-50 : 8,5		-LM		Tipo compacto (Comprimento isolador: 14,5mm)		
										N		Eléctrodo de massa especial		-S	Anel de vedação especial
										P		Eléctrodo de platina Eléctrodo de terra simples: Dupla platina		-E	Resistência especial
												Eléctrodo de multi-terra: Platina simples em eléctrodo central		IX-P	Ficha MAX de Iridio
										Q		4 eléctrodos de terra		LPG 1-8	LGamma de vela de ignição LaserLine para uso em motor a gás
										S		Tipo padrão			
										T		3 eléctrodos de terra			
										U		Tipo faísca semi-deslizante			
										Y		Eléctrodo central com corte em V			
										Z		Construção especial			



Como ler o nosso número de peça: Velas de ignição

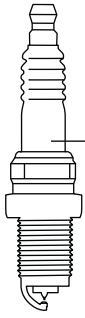

P F R 5 A - 11

Unidade : mm

P		F				R		5		A		-11		
Tipo de vela		Tamanho da rosca	Tamanho da rosca	Configuração do assento	Tamanho do hexágono	Construção		Número de potência térmica	Construção		Espaço da vela			
DI	Ignibilidade especialmente alta, eléctrodos finos de execução dupla	F	Ø 14,0	19,0	Junta circular	Hex 16,0	R	Resistência	2		A,B,C... Código sufixo	vacio	Mota: 0,7-0,8 Carro: 0,8-0,9	
I	Vela de ignição de irídio duplo	FE	Ø 14,0	19,0	Junta circular	Hex 16,0		4				-7	0,7	
L	Rosca especialmente longa	G	Ø 14,0	19,0	Junta circular	Hex 20,8		5				-9	0,9	
P	Vela de ignição de platina dupla	J	Ø 12,0	19,0	Junta circular	Hex 18,0		6				-10	1,0	
S	Ficha de alta inflamabilidade: tipo ponta quadrada fina	K	Ø 12,0	19,0	Junta circular	Hex 16,0		7			I	Eléctrodo central de irídio	-11	1,1
Z	Ponta de ignição projetada	KA	Ø 12,0	19,0	Junta circular	Hex 14,0		8			IX	Vela de irídio	-13	1,3
		KB	Ø 12,0	19,0	Junta circular	Bi-Hex 14,0 (Bi-sextavado *)		9			P	Eléctrodo central de platina	-15	1,5
		KE	Ø 12,0	19,0	Junta circular	Hex 16,0		10						
		KF	Ø 12,0	19,0	Junta circular	Hex 14,0								
		KG	Ø 12,0	19,0	Junta circular	Bi-Hex 14,0 (Bi-sextavado *)								
		L	Ø 10,0	12,7	Junta circular	Hex 16,0								
		M	Ø 10,0	19,0	Junta circular	Hex 16,0								
		MA	Ø 10,0	19,0	Junta circular	Hex 14,0								
		MF	Ø 10,0	19,0	Junta circular	Hex 14,0								
		NA	Ø 12,0	17,5	Assento cónico	Hex 14,0								
		T	Ø 14,0	17,5	Assento cónico	Hex 16,0								
		U	Ø 14,0	11,2	Assento cónico	Hex 16,0								
		W	Ø 18,0	10,9	Assento cónico	Hex 20,8								
		X	Ø 14,0	9,5	Junta circular	Hex 20,8								
		Y	Ø 14,0	11,2	Assento cónico	Hex 16,0								
						Bi-sextavado								
						Sextavado								

Os códigos acima indicados podem aparecer em combinação, <Exemplo>ILFR..., PLZFR...
Quando „L“ é incluído, a prioridade é dada a „L“ (longo alcance)* em comprimento do fio.
<Exemplo>
*Vela com junta circular
FR5AP-11; comprimento da rosca 19,0 mm
↓
LFR5AP-11; comprimento da rosca 26,5mm
*Vela com assento cónico
PTR5C-13; comprimento da rosca 17,5 mm
↓
PLTR6A-10G; comprimento da rosca 25,0 mm

* Exceção TR5A-10, TR5A-13, TR5B-13, TR6B-10, TR6B-13, PTR5A-10, PTR5A-13: Comprimento do fio de 25,0 mm
* O perno bi-sextavado é necessário.
* FE, KE, KF, KG, MF : Tipo de comprimento de isolador mais tempo exposto

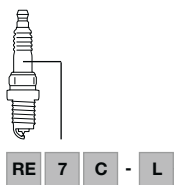

RE		7		C		-L	
Tipo de vela		Número de potência térmica		Construção		Espaço da vela	
RE	Vela para motores rotativos	5		A,B,C... Código sufixo		-L	Lado de liderança
SD	Vela para motores rotativos (Espaço de descarga de semi-superfície)	6				-T	Lado de mudança
		7					
		8					
		9					
		10					
		11					

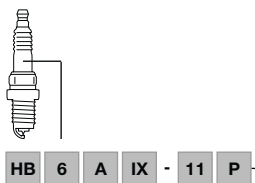

HB		6		A				IX		-11		P	
Tipo de vela		Número de potência térmica		Tamanho da rosca	Tamanho da rosca	Configuração do assento	Tamanho do hexágono	Espaço da vela					
HB	HYBD (3 eléctrodos de terra tipo híbrido)	4		A	Ø 14,0	20,5	Con Junta	Hex 16,0	IX	-8	0,8		
		5		B	Ø 14,0	19,0	Con Junta	Hex 16,0		-9	0,9		
		6								-10	1,0		
		7								-11	1,1		
		8							-13	1,3			

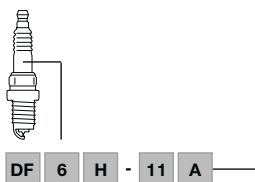

DF		6		H				-11		A	
Tipo de vela		Número de potência térmica		Tamanho da rosca	Tamanho da rosca	Configuração do assento	Tamanho do hexágono	Espaço da vela			
DF	Vela de alta inflamabilidade (eléctrodos finos duplos)	4		A	Ø 14,0	19,0	Con Junta	Hex 16,0	-8	0,8	A,B,C... Código sufixo
		5		B	Ø 14,0	26,5	Con Junta	Hex 16,0	-9	0,9	
DFH	Vela de alta inflamabilidade (DF + Tipo híbrido)	6		C	Ø 12,0	26,5	Con Junta	Hex 14,0	-10	1,0	
		7		*DF6H-11A : Tamanho da rosca 28,0 mm				-11	1,1		
		8						-13	1,3		
		9					-15	1,5			

Πώς να ερμηνεύετε τους κωδικούς μας: Μπουζί

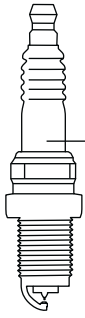

B P R 5 E S - 11

Μονάδα: mm

B		P		R		5		E		S		-11			
Διάμετρος σπειρώματος	εξάγωνο	Δομή	Αντιπαρασπτική αντίσταση	Τιμή θερμότητας	Μήκος σπειρώματος	Χαρακτηριστικά κατασκευής	Διάκενο ηλεκτροδίου								
A	φ 18,0	Hex 25,4	P	προωθημένο άκρο μονωτήρα	R	Αντίσταση	2	θερμός τύπος	E	19,0	B	σταθερό παξιμάδι σύνδεσης SAE (CR8EB)	κενό	Μοτοσικλέτα: 0,7~0,8	
B	φ 14,0	Hex 20,8	M	Συμπαγές μπουζί	Z	επαγωγική αντίσταση	4		EF	17,5	CM	Ηλεκτρόδιο γείωσης Συμπαγούς τύπου (Μήκος εκτεθειμένου μονωτή: 18,5)	κενό	Αυτοκίνητο: 0,8~0,9	
BC	φ 14,0	Hex 16,0					5		EH	19,0 μισή εκτέλεση					
BK	φ 14,0	Hex 16,0	6	H	12,7										
C	φ 12,0	Hex 16,0	U	Τύπος ολισθαίνοντα σπινθήρα ή πρόσθετης διαδρομής σπινθήρα	7	L	11,2		κενό	Κωνική στεγανή εφαρμογή A(P)-F : 10,9 B(P)-F : 11,2 BM(P)-F : 7,8	G,GV	Αγωνιστικό μπουζί	-8	0,8	
D	φ 10,0	Hex 18,0			8	κενό	Μπουζί μικρού τύπου B(P)M- : 9,5 B-LM : 9,5 CM- : 9,5 CM-6 : 8,6 C-50 : 8,5								I
DC	φ 12,0	Hex 16,0			9				κενό	IX	Μπουζί ιριδίου	-10	1,0		
E	φ 8,0	Hex 13,0			10	ψυχροί τύποι	J							Ηλεκτρόδια που προεξέχουν από το έδαφος	-11
* Εξάφαιση B(P)M-A,Y : φ 14,0, Hex 19,0 P(P)-(E)F : φ 14,0, Hex 16,0 CM-6 : φ 10,0, Hex 14,0		BC : Παλιό JIS κανονικό μέγεθος Το μήκος από το κύκλωμα φλάντζας ως την επαφή θερματικού είναι 53,0mm.		BK : ISO / JIS κανονικό μέγεθος 50,5mm. Το μήκος από το κύκλωμα φλάντζας ως την επαφή θερματικού είναι 50,5mm.					-13		1,3	-15	1,5	-S	
									K						2 ηλεκτρόδια γείωσης
									-LM		Συμπαγείς τύποι(Μήκος μονωτήρα: 14,5 mm)	-15	1,5	-S	
								N		ειδικό ηλεκτρόδιο γείωσης	-15				1,5
								P		Ηλεκτρόδιο πλατίνια Απλό ηλεκτρόδιο γείωσης: Διπλή πλατίνια Πολλαπλό ηλεκτρόδιο γείωσης: Μονή πλατίνια σε κεντρικό ηλεκτρόδιο		-15	1,5	-S	
								Q		Τετραπλά ηλεκτρόδια γείωσης	-15				1,5
								S		Στάνταρ τύπος		-15	1,5	-S	
								T		Τριπλά ηλεκτρόδια γείωσης	-15				1,5
								U		Τύπος σπινθήρα μισής ολισθησης		-15	1,5	-S	
								Y		Μεσαίο ηλεκτρόδιο με εγκοπή V	-15				1,5
								Z		ειδική κατασκευή		-15	1,5	-S	



Πώς να ερμηνεύετε τους κωδικούς μας: Μπουζί

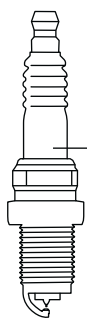

P F R 5 A - 11

Μονάδα: mm

P		F				R		5		A		-11		
Τύπος		Διάμετρος σπειρώματος	Μήκος σπειρώματος	Διαμόρφωση θέσης	εξάγωνο	Αντιπαρασκή αντίσταση		Τιμή θερμότητας		Κατασκευή	Διάκενο ηλεκτροδίου			
DI	ιδιαίτερα ψηλή ικανότητα ανάφλεξης, λεπτά ηλεκτρόδια διπλής εκτέλεσης	F	φ 14,0	19,0	Στεγανοποιητικός δακτύλιος	Hex 16,0	R	Αντίσταση	2	<p>θερμός τύπος</p> <p>ψυχροί τύποι</p>	A,B,C... Suffix code	κενό	Μοτοσικλέτα: 0,7-0,8 Αυτοκίνητο: 0,8-0,9	
I	Διπλό μπουζί ιριδίου	FE	φ 14,0	19,0	Στεγανοποιητικός δακτύλιος	Hex 16,0		4				-7	0,7	
L	ιδιαίτερα μακρύ σπείρωμα	G	φ 14,0	19,0	Στεγανοποιητικός δακτύλιος	Hex 20,8		5				-9	0,9	
P	Διπλό μπουζί πλατινίας	J	φ 12,0	19,0	Στεγανοποιητικός δακτύλιος	Hex 18,0		6				-10	1,0	
S	Μπουζί υψηλής αναφλεξιμότητας: τύπος λεπτής τετράγωνης άκρης	K	φ 12,0	19,0	Στεγανοποιητικός δακτύλιος	Hex 16,0		7			I	Κεντρικό ηλεκτρόδιο ιριδίου	-11	1,1
Z	Προβλεπόμενη θέση πυρόδότησης	KA	φ 12,0	19,0	Στεγανοποιητικός δακτύλιος	Hex 14,0		8			IX	Μπουζί ιριδίου	-13	1,3
		KB	φ 12,0	19,0	Στεγανοποιητικός δακτύλιος	Bi-Hex 14,0 (Διπλή εξαγωνική *)		9			P	Κεντρικό ηλεκτρόδιο πλατινίας	-15	1,5
		KE	φ 12,0	19,0	Στεγανοποιητικός δακτύλιος	Hex 16,0		10						
		KF	φ 12,0	19,0	Στεγανοποιητικός δακτύλιος	Hex 14,0								
		KG	φ 12,0	19,0	Στεγανοποιητικός δακτύλιος	Bi-Hex 14,0 (Διπλή εξαγωνική *)								
		L	φ 10,0	12,7	Στεγανοποιητικός δακτύλιος	Hex 16,0								
		M	φ 10,0	19,0	Στεγανοποιητικός δακτύλιος	Hex 16,0								
		MA	φ 10,0	19,0	Στεγανοποιητικός δακτύλιος	Hex 14,0								
		MF	φ 10,0	19,0	Στεγανοποιητικός δακτύλιος	Hex 14,0								
		NA	φ 12,0	17,5	Κωνική στεγανή εφαρμογή	Hex 14,0								
		T	φ 14,0	17,5	Κωνική στεγανή εφαρμογή	Hex 16,0								
		U	φ 14,0	11,2	Κωνική στεγανή εφαρμογή	Hex 16,0								
		W	φ 18,0	10,9	Κωνική στεγανή εφαρμογή	Hex 20,8								
		X	φ 14,0	9,5	Στεγανοποιητικός δακτύλιος	Hex 20,8								
		Y	φ 14,0	11,2	Κωνική στεγανή εφαρμογή	Hex 16,0								
						Διπλή εξαγωνική								
						Εξαγωνική								

Τα παραπάνω αναφερόμενα χαρακτηριστικά μπορεί να παρουσιάσουν συνδυασμένα, <Παράδειγμα> ILFR..., PLZFR..., Όταν συμπεριλαμβάνεται „L“, δίνεται προτεραιότητα στο „L“ (μεγάλη εμβέλεια) στο μήκος σπειρώματος.

<Παράδειγμα>
* Μπουζί με στεγανοποιητικό δακτύλιο
FR5AP : μήκος σπειρώματος 19,0mm
LFR5AP-11 : μήκος σπειρώματος 26,5mm
* μπουζί με κωνική στεγανή εφαρμογή
PTR5C-13 : μήκος σπειρώματος 17,5mm
PLTR6A-10G : μήκος σπειρώματος 25,0mm

* Εξαιρέση TR5A-10, TR5A-13, TR5B-13, TR6B-10, TR6B-13, PTR5A-10, PTR5A-13 : μήκος σπειρώματος 25,0mm
* Απαιτείται διπλή εξαγωνική υποδοχή.
* FE, KE, KF, KG, MF : Τύπος μήκους μακρύτερου εκτεθειμένου μονωτή

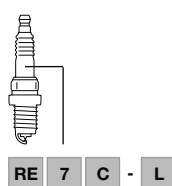

RE		7		C		-L		
Τύπος		Τιμή θερμότητας		Κατασκευή		Διάκενο ηλεκτροδίου		
RE	Μπουζί για περιστροφικούς κινητήρες	5	<p>θερμός τύπος</p> <p>ψυχροί τύποι</p>	A,B,C... Suffix code		-L	Μπροσινή πλευρά	
SD	Μπουζί για περιστροφικούς κινητήρες (Διάκενο εκκένωσης ημι-επιφάνειας)	6					-T	Πλευρά σύνδεσης
		7						
		8						
		9						
		10						
		11						

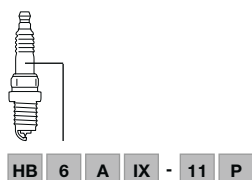

HB		6		A				IX		-11		P		
Τύπος		Τιμή θερμότητας		Διάμετρος σπειρώματος	Μήκος σπειρώματος	Διαμόρφωση θέσης	εξάγωνο			Διάκενο ηλεκτροδίου				
HB	HYBD (τριπλό ηλεκτρόδιο γείωσης υβριδικού τύπου)	4	<p>θερμός τύπος</p> <p>ψυχροί τύποι</p>	A	φ 14,0	20,5	Στεγανοποιητικός δακτύλιος	Hex 16,0	IX	-8	0,8			
		5			B	φ 14,0	19,0	Στεγανοποιητικός δακτύλιος	Hex 16,0		-9	0,9		
		6									-10	1,0		
		7									-11	1,1		
		8								-13	1,3			

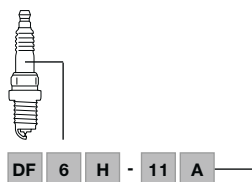

DF		6		H				-11		A			
Τύπος		Τιμή θερμότητας		Διάμετρος σπειρώματος	Μήκος σπειρώματος	Διαμόρφωση θέσης	εξάγωνο			Διάκενο ηλεκτροδίου			
DF	Μπουζί υψηλής αναφλεξιμότητας (Διπλά λεπτά ηλεκτρόδια)	4	<p>θερμός τύπος</p> <p>ψυχροί τύποι</p>	A	φ 14,0	19,0	Στεγανοποιητικός δακτύλιος	Hex 16,0		-8	0,8	A,B,C... Suffix code	
DFH	Μπουζί υψηλής αναφλεξιμότητας (DF + Υβριδικού τύπου)	5			B	φ 14,0	26,5	Στεγανοποιητικός δακτύλιος	Hex 16,0		-9	0,9	
		6			C	φ 12,0	26,5	Στεγανοποιητικός δακτύλιος	Hex 14,0		-10	1,0	
		7			* DF6H-11A : Μήκος σπειρώματος 28,0mm						-11	1,1	
		8									-13	1,3	
		9								-15	1,5		

Parça numaramızın okunma şekli: Ateşleme Bujileri

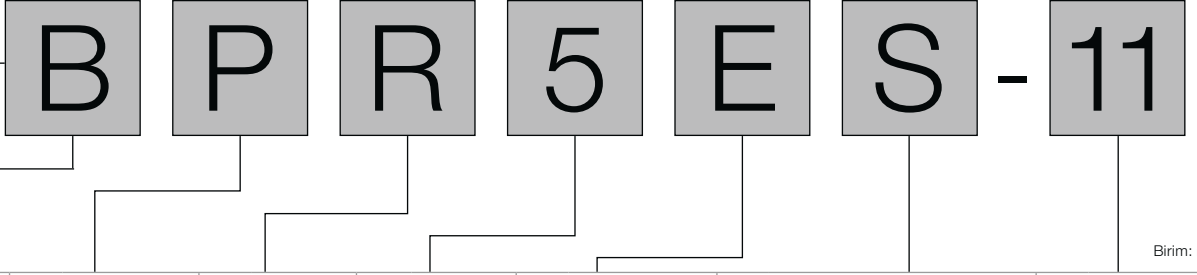
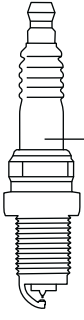

Birim: mm

B			P		R		5		E		S		-11	
	Diş çapı	altı köşeli	Yapı	Parazit giderme direnci	Isı değeri		Diş uzunluğu		Konstrüksiyon özellikleri		Elektrot mesafesi			
A	ø 18,0	Hex 25,4	P	Öne itilmiş izolatör ucu	R	Direnç	2		E	19,0	B	sabit SAE-bağlantı somunu (CR8EB)	boş	Motosiklet: 0,7~0,8
B	ø 14,0	Hex 20,8		Z	indüktif direnç	4	EF		17,5	CM	Eğri şasi elektrodu Kompakt tip (Açıktaki izolasyon uzunluğu: 18,5)		Araba: 0,8~0,9	
BC	ø 14,0	Hex 16,0	M	Kompakt buji		5	EH		19,0 yarım yapılmış	CS	Eğri şasi elektrodu	-8	0,8	
BK	ø 14,0	Hex 16,0				6	H		12,7	G,GV	Yarış bujisi	-9	0,9	
C	ø 10,0	Hex 16,0	U	Kayar kıvılcım tipi veya Kayar kıvılcım tipi veya		7	L		11,2	I	İridiyum çekirdekli elektrot	-10	1,0	
D	ø 12,0	Hex 18,0				8				IX	İridiyum buji	-11	1,1	
DC	ø 12,0	Hex 16,0				9	boş		Konik sızdırmaz valf A(P)-F : 10,9 B(P)-F : 11,2 BM(P)-F : 7,8	J	2 çıkıntılı şasi elektrodu	-13	1,3	
E	ø 8,0	Hex 13,0				10			Küçük tipte buji B(P)M : 9,5 B-LM : 9,5 CM : 9,5 CM-6 : 8,6 C-50 : 8,5	K	2 şasi elektrodu	-15	1,5	
*İstisna B(P)M-A,Y : ø 14,0, Hex 19,0 P(P)-(E)F : ø 14,0, Hex 16,0 CM-6 : ø 10,0, Hex 14,0										-LM	Kompakt tip (izolatör uzunluğu: 14,5mm)			
BC : Eski JIS standart boyut Conta devresinden terminal kantağına kadar uzunluk 53,0 mm'dir.										N	özel toprak elektrodu	-S	özel conta	
BK : ISO / JIS standart boyut Conta devresinden terminal kantağına kadar uzunluk 50,5 mm'dir.									P	Platin elektrodu Tekli şasi elektrodu: Çift platinyum Çoklu şasi elektrodu: Tekli platinyum çekirdekli elektrot	-E	özel direnç		
									Q	4 şasi elektrodu			IX-P	İridiyum MAKS buji
									S	Standart tip			LPG 1-8	Gazlı motorda kullanım için Laser Line kızdırma bujisi
									T	3 şasi elektrodu				
									U	Yarım kayar kıvılcım tipi				
									Y	V-çentikli orta elektrot				
									Z	özel tasarım				



Parça numaramızın okunma şekli: Ateşleme Bujileri

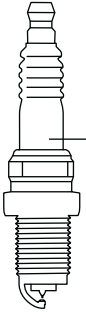

P F R 5 A - 11

Birim: mm

P		F				R		5		A		-11		
Bujisi tipi		Diş çapı	Diş uzunluğu	Koltuk konfigürasyonu	altı köşeli	Gürültü direnci		Isı değeri		Konstrüksiyon		Elektrot aralığı		
DI	daha yüksek ateşleme kapasitesi, çift tasarımı, ince elektrotlar	F	ø 14,0	19,0	Conta	Hex 16,0	R	Direnç	2	<p>sıcak tip buji</p> <p>soğuk tip buji</p>	A,B,C... Suffix code	boş	Motosiklet: 0,7-0,8 Otomobil: 0,8-0,9	
I	İkili iridyum kızdırma bujisi	FE	ø 14,0	19,0	Conta	Hex 16,0		4				-7	0,7	
L	daha uzun vidalama	G	ø 14,0	19,0	Conta	Hex 20,8		5				-9	0,9	
P	İkili platinyum kızdırma bujisi	J	ø 12,0	19,0	Conta	Hex 18,0		6				-10	1,0	
S	Yüksek yanmalı buji: ince kare uçlu tip	K	ø 12,0	19,0	Conta	Hex 16,0		7			I	İridiyum çekirdekli elektrot	-11	1,1
Z	Korunmalı ateşleme ucu	KA	ø 12,0	19,0	Conta	Hex 14,0		8			IX	İridiyum buji	-13	1,3
		KB	ø 12,0	19,0	Conta	Bi-Hex 14,0 (İkili altıgen *)		9			P	Platinyum çekirdekli elektrot	-15	1,5
		KE	ø 12,0	19,0	Conta	Hex 16,0		10						
		KF	ø 12,0	19,0	Conta	Hex 14,0								
		KG	ø 12,0	19,0	Conta	Bi-Hex 14,0 (İkili altıgen *)								
		L	ø 10,0	12,7	Conta	Hex 16,0								
		M	ø 10,0	19,0	Conta	Hex 16,0								
		MA	ø 10,0	19,0	Conta	Hex 14,0								
		MF	ø 10,0	19,0	Conta	Hex 14,0								
		NA	ø 12,0	17,5	Konik sızdırmaz	Hex 14,0								
		T	ø 14,0	17,5	Konik sızdırmaz	Hex 16,0								
		U	ø 14,0	11,2	Konik sızdırmaz	Hex 16,0								
		W	ø 18,0	10,9	Konik sızdırmaz	Hex 20,8								
		X	ø 14,0	9,5	Conta	Hex 20,8								
		Y	ø 14,0	11,2	Konik sızdırmaz	Hex 16,0								
						İkili altıgen								
						Altıgen								

Yukarıda belirtilen işaretler kombine şekilde görülebilirler,
<Örnek>ILFR..., PLZFR...,
„L“ eklendiğinde, diş uzunluğunda „L“ (uzun) boyutuna öncelik verilir.
<Örnek>
*Contalı buji
FR5AP : vidalama uzunluğu 19,0mm
↓
LFR5AP-11 : vidalama uzunluğu 26,5mm
*Konik sızdırmaz valfli buji
PTR5C-13 : vidalama uzunluğu 17,5mm
↓
PLTR6A-10G : vidalama uzunluğu 25,0mm

* İstisna TR5A-10, TR5A-13, TR5B-13, TR6B-10, TR6B-13, PTR5A-10, PTR5A-13 : Diş uzunluğu 25,0mm
* İkili altıgen soket gereklidir.
* FE, KE, KF, KG, MF: Daha fazla açıkta kalan izolasyon tipi

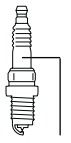

RE 7 C - L

RE		7		C		-L	
Bujisi tipi		Isı değeri		Konstrüksiyon		Elektrot aralığı	
RE	Dönen motorlar için buji	5	<p>sıcak tip buji</p> <p>soğuk tip buji</p>	A,B,C... Suffix code		-L	Önde gelen taraf
SD	Dönen motorlar için buji (Yarı yüzeyli deşarj boşluğu)	6				-T	İzleyen taraf
		7					
		8					
		9					
		10					
		11					

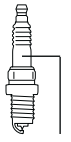

HB 6 A IX - 11 P

HB		6		A				IX		-11		P		
Bujisi tipi		Isı değeri		Diş çapı	Diş uzunluğu	Koltuk konfigürasyonu	altı köşeli			Elektrot aralığı				
HB	HYBD (3 şasi elektrodu hibrit tipi)	4	<p>sıcak tip buji</p> <p>soğuk tip buji</p>	A	ø 14,0	20,5	Conta	Hex 16,0	IX	-8	0,8			
		5			B	ø 14,0	19,0	Conta	Hex 16,0		-9	0,9		
		6									-10	1,0		
		7									-11	1,1		
		8									-13	1,3		

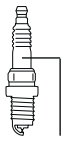

DF 6 H - 11 A

DF		6		H				-11		A		
Bujisi tipi		Isı değeri		Diş çapı	Diş uzunluğu	Koltuk konfigürasyonu	altı köşeli	Elektrot aralığı				
DF	Yüksek yanmalı buji (İkili hassas elektrot)	4	<p>sıcak tip buji</p> <p>soğuk tip buji</p>	A	ø 14,0	19,0	Conta	Hex 16,0	-8	0,8	A,B,C... Suffix code	
		5			B	ø 14,0	26,5	Conta	Hex 16,0	-9	0,9	
		6			C	ø 12,0	26,5	Conta	Hex 14,0	-10	1,0	
		7			*DF6H-11A : Diş uzunluğu 28,0mm				-11	1,1		
		8								-13	1,3	
		9								-15	1,5	

Jak odczytać numer części: Świece zapłonowe

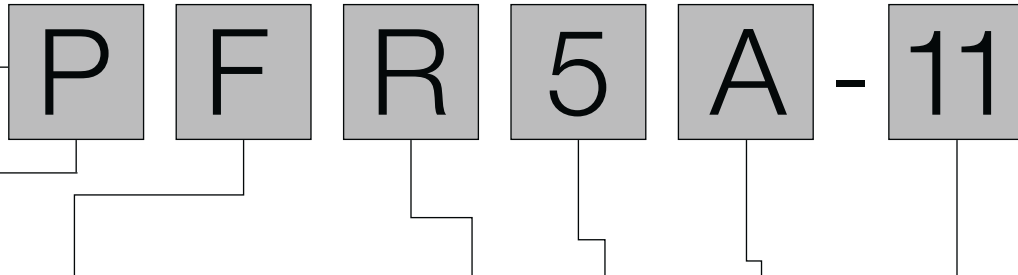
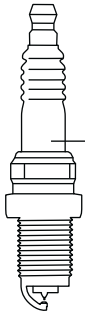

Jednostka: mm

P		F				R		5		A		-11					
Typ świecy		Średnica gwintu	Długość gwintu	Konfiguracja gniazda	rozwartość klucza sześciokątnego	Opornik przeciwzakłóceniu		Wartość cieplna		Konstrukcja		Odstęp elektrod					
DI	Wysoka zdolność zapłonu, Podwójne, cienkie elektrody	F	∅ 14,0	19,0	Pierścień uszczelniający	Hex 16,0	R	Opornik		A,B,C... kod przyrostka		leer Motocykl: 0,7-0,8 Samochód: 0,8-0,9					
		FE	∅ 14,0	19,0	Pierścień uszczelniający	Hex 16,0											
I	Podwójna irydowa świeca zapłonowa	G	∅ 14,0	19,0	Pierścień uszczelniający	Hex 20,8	4	I Irydowa elektroda centralna IX Elektroda irydowa - typ IX P Platynowa elektroda centralna						-7	0,7		
L	Długi gwint	J	∅ 12,0	19,0	Pierścień uszczelniający	Hex 18,0	5							-9	0,9		
							6							-10	1,0		
P	Podwójna platynowa świeca zapłonowa	K	∅ 12,0	19,0	Pierścień uszczelniający	Hex 16,0	7							-11	1,1		
S	Świeca o dużej zapłonowości: typ z wąską końcówką kwadratową	KA	∅ 12,0	19,0	Pierścień uszczelniający	Hex 14,0	8							IX Elektroda irydowa - typ IX P Platynowa elektroda centralna	-13	1,3	
							KB								∅ 12,0	19,0	Pierścień uszczelniający
Z	Wysunięta końcówka z elektrodami	KE	∅ 12,0	19,0	Pierścień uszczelniający	Hex 16,0	9								* Jeśli numer części zaczyna się od liter „I” lub „P” (litery „I” lub „P” po oznaczeniu wartości temperatury są kodem sufiksu). <Przykład> IZFR6P8 jest irydową świecą zapłonową I: Iryd P: Kod sufiksu * <Wyjątek> ZFR0P-G jest niklową świecą zapłonową	-A	brak pierścienia uszczelniającego
Powyższe oznaczenia mogą być łączone <Przykład>ILFR..., PLZFR..., Jeśli dodano „L”, priorytet ma długość Gwintu („L” (długi zasięg)). <Przykład> * świeca z pierścieniem uszczelniającym FR5AP : długość gwintu 19,0mm ↓ LFR5AP-11 : długość gwintu 26,5mm * świeca ze szczelnym gniazdem stożkowym PTR5C-13 : długość gwintu 17,5mm ↓ PLTR6A-10G : długość gwintu 25,0mm	KF	∅ 12,0	19,0	Pierścień uszczelniający	Hex 14,0	10	-J									Gwint specjalny	
	KG	∅ 12,0	19,0	Pierścień uszczelniający	Bi-Hex 14,0 (Dwunastokątne *)	11	-K		2 elektrody masy								
	L	∅ 10,0	12,7	Pierścień uszczelniający	Hex 16,0	12	-L		Elektroda odporna na wibrację, uziemiona								
	M	∅ 10,0	19,0	Pierścień uszczelniający	Hex 16,0	13	-N	Specjalna elektroda masy									
	MA	∅ 10,0	19,0	Pierścień uszczelniający	Hex 14,0	14	-Q	4 elektrody masowe									
	MF	∅ 10,0	19,0	Pierścień uszczelniający	Hex 14,0	15	-S	Specjalny pierścień uszczelniający									
	NA	∅ 12,0	17,5	Szczelne gniazdo stożkowe	Hex 14,0	16	-T	3 elektrody masy									
	T	∅ 14,0	17,5	Szczelne gniazdo stożkowe	Hex 16,0	17	-U	Półpowierzchniowy rodzaj wyładowania									
	U	∅ 14,0	11,2	Szczelne gniazdo stożkowe	Hex 16,0	18	IX-P	Świeca irydowa MAX									
	W	∅ 18,0	10,9	Szczelne gniazdo stożkowe	Hex 20,8	19	LPG 1-8	Oferta świec zapłonowych LaserLine do silników benzynowych									
X	∅ 14,0	9,5	Pierścień uszczelniający	Hex 20,8	20												
Y	∅ 14,0	11,2	Szczelne gniazdo stożkowe	Hex 16,0	21												
* Wyjątek TR5A-10, TR5A-13, TR5B-13, TR6B-10, TR6B-13, PTR5A-10, PTR5A-13: Długość gwintu 25,0mm					Dwunastokątne												
* Wymaga gniazda dwunastokątnego.					Sześciokątne												
* FE, KE, KF, KG, MF: Typ większej długości otwartego izolatora																	

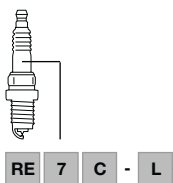

RE		7		C		-L	
Typ świecy		Wartość cieplna		Konstrukcja		Odstęp elektrod	
RE	Świeca do silników rotacyjnych	5		A,B,C... kod przyrostka		-L Dolna strona -T Górna strona	
SD	Świeca do silników rotacyjnych (przerwa wyładowania półpowierzchniowego)	6					
		7					
		8					
		9					
		10					
11							

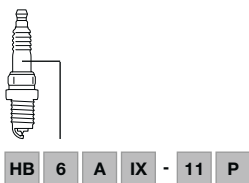

HB		6		A		IX		-11		P	
Typ świecy		Wartość cieplna		Średnica gwintu	Długość gwintu	Konfiguracja gniazda	rozwartość klucza sześciokątnego	Odstęp elektrod			
HB	HYBD (typ hybrydowy z 3 elektrodami uziemionymi)	4		A	∅ 14,0	20,5	Pierścień uszczelniający	Hex 16,0	IX	-8	0,8
		5		B	∅ 14,0	19,0	Pierścień uszczelniający	Hex 16,0		-9	0,9
		6		-10	1,0						
		7		-11	1,1						
		8		-13	1,3						

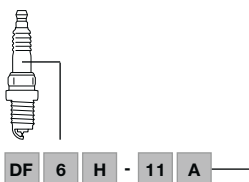

DF		6		H		-11		A				
Typ świecy		Wartość cieplna		Średnica gwintu	Długość gwintu	Konfiguracja gniazda	Sechskant	Odstęp elektrod				
DF	Świeca o dużej zapłonowości (podwójne, cienkie elektrody)	4		A	∅ 14,0	19,0	Pierścień uszczelniający	Hex 16,0	-8	0,8		
		5		B	∅ 14,0	26,5	Pierścień uszczelniający	Hex 16,0			-9	0,9
DFH	Świeca o dużej zapłonowości (Typ DF + hybrydowy)	6		C	∅ 12,0	26,5	Pierścień uszczelniający	Hex 14,0			-10	1,0
		7		* DF6H-11A : Długość gwintu 28,0mm		-11	1,1					
		8		-13	1,3							
9	-15	1,5										

Jak číst naše číslo dílu: Zapalovací svíčky

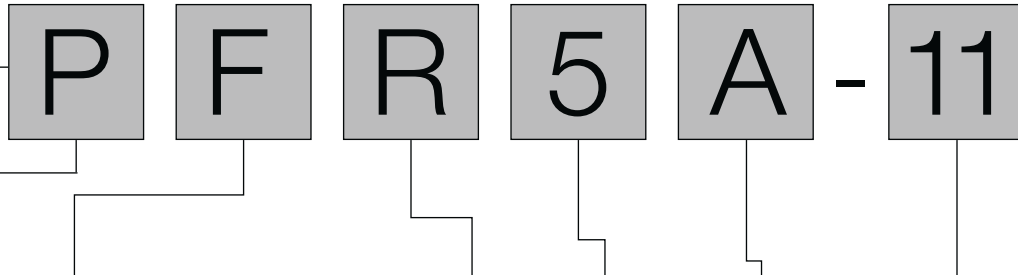
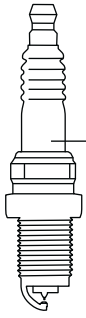

Jednotky: mm

P		F				R		5		A		-11	
Zapalovací typ		Průměr	Délka závitu	Nastavení objímky	šestihran	Odrůsovací odpor		Teplotná hodnota		Konstrukce		Vzdálenost elektrod	
DI	mimořádně vysoká schopnost zapálení, dvojité provedení, jemné elektrody	F	ø 14,0	19,0	Těsnící kroužek	Hex 16,0	R	Odpor	2		A,B,C... kód přípony	prázdné	Motorcykl: 0,7-0,8 Auto: 0,8-0,9
I	Dvojitá iridiová zapalovací svíčka	FE	ø 14,0	19,0	Těsnící kroužek	Hex 16,0		4					
L	mimořádně dlouhý závit	G	ø 14,0	19,0	Těsnící kroužek	Hex 20,8		5					
P	Dvojitá platinová zapalovací svíčka	J	ø 12,0	19,0	Těsnící kroužek	Hex 18,0		6					
S	Svíčka s mimořádně vysokou schopností zapálení: čtvercový platinový čip	K	ø 12,0	19,0	Těsnící kroužek	Hex 16,0		7					
		KA	ø 12,0	19,0	Těsnící kroužek	Hex 14,0		8					
		KB	ø 12,0	19,0	Těsnící kroužek	Bi-Hex 14,0 (Dvojitý šestihřanný *)		9					
								10					
Z	Předsunutá jiskřičtě	KE	ø 12,0	19,0	Těsnící kroužek	Hex 16,0							
		KF	ø 12,0	19,0	Těsnící kroužek	Hex 14,0							
		KG	ø 12,0	19,0	Těsnící kroužek	Bi-Hex 14,0 (Dvojitý šestihřanný *)							
		L	ø 10,0	12,7	Těsnící kroužek	Hex 16,0							
		M	ø 10,0	19,0	Těsnící kroužek	Hex 16,0							
		MA	ø 10,0	19,0	Těsnící kroužek	Hex 14,0							
		MF	ø 10,0	19,0	Těsnící kroužek	Hex 14,0							
		NA	ø 12,0	17,5	Kuželové těsnící sedlo	Hex 14,0							
		T	ø 14,0	17,5	Kuželové těsnící sedlo	Hex 16,0							
		U	ø 14,0	11,2	Kuželové těsnící sedlo	Hex 16,0							
		W	ø 18,0	10,9	Kuželové těsnící sedlo	Hex 20,8							
		X	ø 14,0	9,5	Těsnící kroužek	Hex 20,8							
		Y	ø 14,0	11,2	Kuželové těsnící sedlo	Hex 16,0							
Výše uvedená označení se mohou vyskytovat kombinovaně, <Příklad> IZFR-, PLZFR-, pokud je v kódu „L“, pro mimořádně dlouhý závit stojí „L“ před všemi ostatními písmeny délkového označení. <Příklad> *svíčka s těsnícím kroužkem FR5AP : délka závitu 19,0mm ↓ LFR5AP-11 : délka závitu 26,5mm *svíčka s kuželovým těsnícím sedlem PTR5C-13 : délka závitu 17,5mm ↓ PLTR6A-10G : délka závitu 25,0mm						* Kromě TR5A-10, TR5A-13, TR5B-13, TR6B-10, TR6B-13, PTR5A-10, PTR5A-13: Délka závitu 25,0mm * Je potřeba dvojitý šestihřanný patice * FE, KE, KF, KG, MF: Typ s prodlouženou délkou izolátoru							

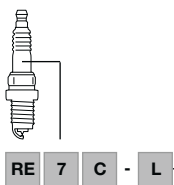

RE		7		C		-L	
Zapalovací typ		Teplotná hodnota		Konstrukce		Vzdálenost elektrod	
RE	Svíčka pro rotační motory	5		A,B,C... kód přípony		-L	Strana předstihu
SD	Svíčka pro rotační motory (Poloviční s klouzavou jiskrou)	6					
		7					
		8					
		9					
		10					
		11				-T	Pracovní strana

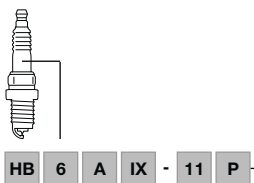

HB		6		A				IX		-11		P	
Zapalovací typ		Teplotná hodnota		Průměr	Délka závitu	Nastavení objímky	šestihran			Vzdálenost elektrod			
HB	HYBD (hybridní typ s 3 zemnicími elektrodami)	4		A	ø 14,0	20,5	Těsnící kroužek	Hex 16,0	IX	-8	0,8		
		5		B	ø 14,0	19,0	Těsnící kroužek	Hex 16,0		-9	0,9		
		6								-10	1,0		
		7								-11	1,1		
		8							-13	1,3			

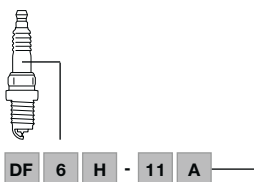

DF		6		H				-11		A		
Zapalovací typ		Teplotná hodnota		Průměr	Délka závitu	Nastavení objímky	šestihran	Vzdálenost elektrod				
DF	Svíčka s mimořádně vysokou schopností zapálení (Dvojitá přesná elektroda)	4		A	ø 14,0	19,0	Těsnící kroužek	Hex 16,0	-8	0,8	A,B,C... kód přípony	
DFH	Svíčka s mimořádně vysokou schopností zapálení (DF + hybridní typ)	5		B	ø 14,0	26,5	Těsnící kroužek	Hex 16,0	-9	0,9		
		6		C	ø 12,0	26,5	Těsnící kroužek	Hex 14,0	-10	1,0		
		7		* DF6H-11A : Délka závitu 28,0mm				-11	1,1			
		8						-13	1,3			
		9					-15	1,5				

Hogyan kell leolvasni a cikkszámot: Gyújtógyertyák

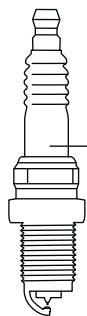

B P R 5 E S - 11

Egység: mm

B		P		R		5		E		S		-11				
Menet átmérő	hatlap	Struktúra	Zavarszűrő ellenállás	Hőérték	Menethossz	Konstrukciós jellemzők		Elektroddahézag								
A	∅ 18,0	Hex 25,4	P	előretolt szigetelőcsúcs	R	Ellenállás	2	<p>meleg típus</p>	E	19,0	B	rögített SAE csatlakozó anyja (CR8EB)	üres	Motorkerékpár: 0,7~0,8 Autó: 0,8~0,9		
B	∅ 14,0	Hex 20,8	M	Kompakt gyertya	Z	induktív ellenállás	4		EF	17,5	CM	Ferde testelektródaKompakt kivétel (Kített szigetelési hossz: 18,5)				
BC	∅ 14,0	Hex 16,0	U	Siklószikrás típus vagy kiegészítő szikraút			5		EH	19,0 félig kivezetett	IX	Ferde testelektróda	-8	0,8		
BK	∅ 14,0	Hex 16,0					6		H	12,7			G,GV	Versenyygyertya	-9	0,9
C	∅ 10,0	Hex 16,0					7		L	11,2			I	Iridium közpételektróda	-10	1,0
D	∅ 12,0	Hex 18,0					8		üres	Kúpos tömítő ülék A(P)-F : 10,9 B(P)-F : 11,2 BM(P)-F : 7,8			IX	iridium gyújtógyertya	-11	1,1
DC	∅ 12,0	Hex 16,0					9								J	2 vetített testelektróda
E	∅ 8,0	Hex 13,0					10		hideg típus	Kis dugó típus B(P)M- : 9,5 B-LM : 9,5 CM- : 9,5 CM-6 : 8,6 C-50 : 8,5			K	2 testelektróda	-15	1,5
*Kivétel B(P)M-A,Y : ∅ 14,0, Hex 19,0 P(P)-(E)F : ∅ 14,0, Hex 16,0 CM-6 : ∅ 10,0, Hex 14,0		BC : Régi JIS szabvány méret A tömítés és a csatlakozás közötti távolság 53,0mm.					BK : ISO / JIS szabvány méret A tömítés és a csatlakozás közötti távolság 50,5mm.		-LM						Kompakt típus (szigetelőhossz: 14,5 mm)	-S
									N	speciális testelektróda			-E	speciális ellenállás		
						P	platina elektróda Egyetlen platina Dupla platina	IX-P	Iridium MAX gyertya							
							Multi testelektróda: Egyetlen platina középelektródában	LPG 1-8	Laserline gyújtógyertya tartomány gázmotor használatra							
						Q	4 testelektróda									
						S	Normál típus									
						T	3 testelektróda									
						U	Félig siklószikrás típus									
						Y	középelektróda V horonnyal									
						Z	speciális kialakítás									



Hogyan kell leolvasni a cikkszámot: Gyújtógyertyák

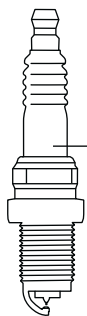

P F R 5 A - 11

Egység: mm

P		F				R		5		A		-11			
Gyertyatípus		Menet átmérő	Menethossz	Fenek konfiguráció	hatlap	Zavarszűrő ellenállás		Hőérték		Konstrukció		Elektrodahézag			
DI	különösen magas gyújtóképesség, duplán kivezetett, finom elektrodák	F	∅ 14,0	19,0	Tömítés	Hex 16,0	R	Ellenállás	2		A,B,C... Suffix code	üres	Motorkerékpár: 0,7-0,8 Autó: 0,8-0,9		
		FE	∅ 14,0	19,0	Tömítés	Hex 16,0			4				-7	0,7	
I	Dupla irídium gyújtógyertya	G	∅ 14,0	19,0	Tömítés	Hex 20,8			5				-9	0,9	
L	különösen hosszú menet	J	∅ 12,0	19,0	Tömítés	Hex 18,0			6				-10	1,0	
P	Dupla paltina gyújtógyertya	K	∅ 12,0	19,0	Tömítés	Hex 16,0			7			I	Iridium középelektroda	-11	1,1
S	Magas hőértékű gyertya: vékony négyzetes hegy típus	KA	∅ 12,0	19,0	Tömítés	Hex 14,0			8			IX	irídium gyújtógyertya	-13	1,3
KB			∅ 12,0	19,0	Tömítés	Bi-Hex 14,0 (Kettős hatszögletű *)			9			P	Platina középelektroda	-15	1,5
Z	Tervezett gyújtógyertya vég								10		hideg típus				
A fent felsorolt jelölések kombinációként is előfordulhatnak. <Példa>ILFR..., PLZFR..., Amikor „L” szerepel, prioritást kap az „L” (hosszú menet) a menethosszban. <Példa> *gyertya tömítéssel FR5AP : menethossz ↓ 19,0mm LFR5AP-11 : menethossz 26,5mm *gyertya kúpos tömítő ülékkel PTR5C-13 : menethossz ↓ 17,5mm PLTR6A-10G : menethossz 25,0mm		KE	∅ 12,0	19,0	Tömítés	Hex 16,0								-A	nincs tömítőgyűrű
		KF	∅ 12,0	19,0	Tömítés	Hex 14,0								-D	Fém persely: galvanizált
		KG	∅ 12,0	19,0	Tömítés	Hex 14,0 (Kettős hatszögletű *)							-E	speciális ellenállás	
		L	∅ 10,0	12,7	Tömítés	Hex 16,0							-G	Rézmagos testelektroda	
		M	∅ 10,0	19,0	Tömítés	Hex 16,0							-H	speciális menet	
		MA	∅ 10,0	19,0	Tömítés	Hex 14,0							-J	2 testelektroda	
		MF	∅ 10,0	19,0	Tömítés	Hex 14,0							-K	Testelektroda rezgéssel szembeni ellenállása	
		NA	∅ 12,0	17,5	Kúpos tömítő ülék	Hex 14,0							-N	speciális testelektroda	
		T	∅ 14,0	17,5	Kúpos tömítő ülék	Hex 16,0							-Q	4 testelektroda	
		U	∅ 14,0	11,2	Kúpos tömítő ülék	Hex 16,0							-S	speciális tömítőgyűrű	
		W	∅ 18,0	10,9	Kúpos tömítő ülék	Hex 20,8							-T	3 testelektroda	
		X	∅ 14,0	9,5	Tömítés	Hex 20,8							-U	Fél kúpszószikrás típus	
		Y	∅ 14,0	11,2	Kúpos tömítő ülék	Hex 16,0							IX-P	Iridium MAX gyertya	
		* Kivétel TR5A-10, TR5A-13, TR5B-13, TR6B-10, TR6B-13, PTR5A-10, PTR5A-13 : Menethossz 25,0mm				Kettős hatszögletű								LPG 1-8	Lasertline gyújtógyertya tartomány gázmotor használatra
		** Kettős hatszögletű aljzat szükséges.				Hatszögletű									
		* FE, KE, KF, KG, MF : Hosszabban kitétt szigetelés hossz típus													

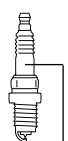

RE 7 C - L

RE		7		C		-L	
Gyertyatípus		Hőérték		Konstrukció		Elektrodahézag	
RE	Forgódugattyús motor gyertya	5		A,B,C... Suffix code		-L	Leading oldal
SD	Forgódugattyús motor gyertya (Fél kúpszószikrás hézag)	6				-T	Trading oldal
		7					
		8					
		9					
		10					
		11	hideg típus				

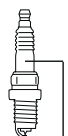

HB 6 A IX - 11 P

HB		6		A				IX		-11		P	
Gyertyatípus		Hőérték		Menet átmérő	Menethossz	Fenek konfiguráció	hatlap			Elektrodahézag			
HB	HYBD (3 testelektroda hibrid típus)	4		A	∅ 14,0	20,5	Tömítés	Hex 16,0	IX	-8	0,8		
		5		B	∅ 14,0	19,0	Tömítés	Hex 16,0		-9	0,9		
		6								-10	1,0		
		7								-11	1,1		
		8	hideg típus						-13	1,3			

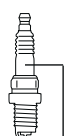

DF 6 H - 11 A

DF		6		H				-11		A	
Gyertyatípus		Hőérték		Menet átmérő	Menethossz	Fenek konfiguráció	hatlap	Elektrodahézag			
DF	Nagy hőértékű gyertya (dupla finom elektrodák)	4		A	∅ 14,0	19,0	Tömítés	Hex 16,0	-8	0,8	A,B,C... Suffix code
		5		B	∅ 14,0	26,5	Tömítés	Hex 16,0	-9	0,9	
DFH	Nagy hőértékű gyertya (DF + hibrid típus)	6		C	∅ 12,0	26,5	Tömítés	Hex 14,0	-10	1,0	
		7		* DF6H-11A : Menethossz 28,0mm					-11	1,1	
		8							-13	1,3	
		9	hideg típus					-15	1,5		

Что означает код детали: Свечи накаливания

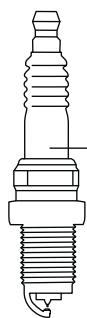

B P R 5 E S - 11

Единица измерения : мм

B		P		R		5		E		S		-11					
Диаметр резьбы	Шестигранник	Структура	Помехоподавляющий резистор	Калильное число	Длина резьбы	Конструктивные особенности		Межэлектродный зазор									
A	∅ 18,0	Hex 25,4	P с выступающим изолятором	R с резистором	2		E	19,0	B	Неподвижная контактная гайка SAE (CR8EB)	leer	Мотоцикл: 0,7~0,8 Автомобиль: 0,8~0,9					
B	∅ 14,0	Hex 20,8	M	Z с индуктивным резистором	4		EF	17,5	CM	Наклонный боковой электрод Компактный тип (длина выступающего изолятора: 18,5)							
BC	∅ 14,0	Hex 16,0	U Тип с поверхностным разрядом или дополнительным искровым зазором		5		EH	19,0 с частично нарезанной резьбой, длина резьбы 12,7mm	CS	Наклонный боковой электрод	-8	0,8					
BK	∅ 14,0	Hex 16,0			6		H	12,7	GV	Гоночная свеча зажигания	-9	0,9					
C	∅ 10,0	Hex 16,0			7		L	11,2	I	Иридиевый центральный электрод	-10	1,0					
D	∅ 12,0	Hex 18,0			8		пустой	Коническая плотная посадка A(P)-F : 10,9 V(P)-F : 11,2 VM(P)-F : 7,8 Компактная свеча V(P)M- : 9,5 V-LM- : 9,5 CM- : 9,5 CM-6 : 8,6 C-50 : 8,5	J	2 удлиненных боковых электрода	-11	1,1					
DC	∅ 12,0	Hex 16,0			9				K	2 боковых электрода	-13	1,3					
E	∅ 8,0	Hex 13,0			10				LM	Компактный тип (Длина изолятора: 14,5 мм)	-15	1,5					
*Исключения B(P)M-A,Y : ∅ 14,0, Hex 19,0 P(P)-(E)F : ∅ 14,0, Hex 16,0 CM-6 : ∅ 10,0, Hex 14,0		BC : Устаревший размер по японским промышленным стандартам JIS Расстояние от уплотняющей прокладки до контактного вывода составляет 53,0 мм.			BK : Стандартный размер ISO/JIS Расстояние от уплотняющей прокладки до контактного вывода составляет 50,5 мм.				P		Платиновый электрод Один боковой электрод : двойной платиновый Несколько боковых электродов: Одинарный платиновый центральный электрод	-S	Специальное уплотнительное кольцо	-E	Специальное сопротивление		
									Q		4 боковых электрода	IX-P	Свеча Iridium MAX	LPG 1-8	Свеча зажигания LaserLine для использования в газовых двигателях		
									S		Стандартный тип						
									T		3 боковых электрода						
						U			Тип с полуповерхностным разрядом								
						Y			Центральный электрод с V-образной насечкой								
						Z			Специальная конструкция								



Что означает код детали: Свечи накаливания

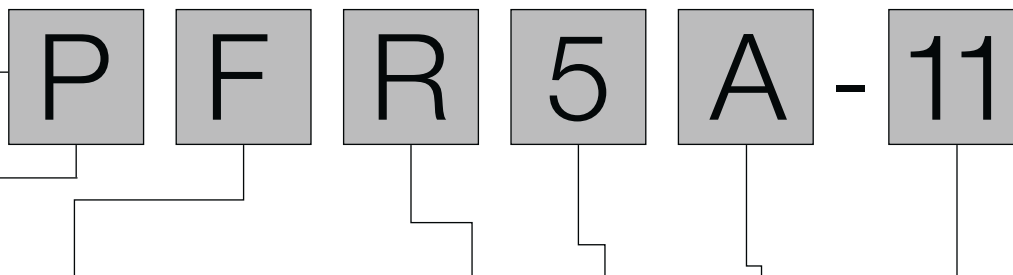
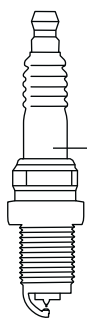

Единица измерения : мм

P		F				R	5	A	-11				
Типы свечей зажигания		Диаметр резьбы	Длина резьбы	Тип основания	Длина резьбы	Помехоподавляющий резистор	Калильное число	Конструкция	Межэлектродный зазор				
DI	Свеча с повышенной надежностью зажигания, с особо тонким электродом	F	∅ 14,0	19,0	Уплотнительное кольцо	R 10 резистором	2		A,B,C... Suffix код	пустой	Мотоцикл: 0,7-0,8		
		FE	∅ 14,0	19,0	Уплотнительное кольцо		Hex 16,0		4		Автомобиль: 0,8-0,9		
I	Двойная иридиевая свеча зажигания	G	∅ 14,0	19,0	Уплотнительное кольцо		5			I Иридиевый центральный электрод IX Иридиевый электрод (IX) P Платиновый центральный электрод	-7	0,7	
		J	∅ 12,0	19,0	Уплотнительное кольцо		Hex 18,0					-9	0,9
L	Удлиненная резьбовая часть	K	∅ 12,0	19,0	Уплотнительное кольцо		Hex 16,0				7	-10	1,0
P	Двойная платиновая свеча зажигания	KA	∅ 12,0	19,0	Уплотнительное кольцо		Hex 14,0				8	-11	1,1
		KB	∅ 12,0	19,0	Уплотнительное кольцо		Bi-Hex 14,0 (Bi-hexagonal *)				9	-13	1,3
S	Свеча с повышенной надежностью зажигания : тонкая квадратная платиновая вставка	KE	∅ 12,0	19,0	Уплотнительное кольцо		Hex 16,0				10	-15	1,5
Z	выступающий запальный конец	KF	∅ 12,0	19,0	Уплотнительное кольцо		Hex 14,0				* При наличии индекса «I» или «P» в начале номера детали («I» или «P» после калильного числа становятся кодовым индексом.) <Пример> IZFR6P8 – иридиевая свеча зажигания I : Иридиевая P : Кодовый индекс * <Исключение> ZFR0P-G – никелевая свеча зажигания	-A	без уплотнительного кольца
Указанные выше обозначения могут быть комбинированными, <Пример>ILFR..., PLZFR..., При наличии индекса «L», приоритетным в определении длины резьбы является индекс «L» (длинная резьбовая часть). <Пример> * Свеча с уплотнительным кольцом FR5AP : длина резьбы 19,0мм ↓ LFR5AP-11 : длина резьбы 26,5мм * Свеча с конической плотной посадкой PTR5C-13 : длина резьбы 17,5мм ↓ PLTR6A-10G : длина резьбы 25,0мм		KG	∅ 12,0	19,0	Уплотнительное кольцо		Hex 14,0 (Bi-hexagonal *)					-D	Никелевое покрытие металлического корпуса
L	∅ 10,0	12,7	Уплотнительное кольцо	Hex 16,0	-E	Специальное сопротивление							
M	∅ 10,0	19,0	Уплотнительное кольцо	Hex 16,0	-G	Боковой электрод с медным сердечником							
MA	∅ 10,0	19,0	Уплотнительное кольцо	Hex 14,0	-H	Специальная резьба							
MF	∅ 10,0	19,0	Уплотнительное кольцо	Hex 14,0	-J	2 боковых электрода							
NA	∅ 12,0	17,5	Коническая плотная посадка	Hex 14,0	-K	Вибростойкий боковой электрод							
T	∅ 14,0	17,5	Коническая плотная посадка	Hex 16,0	-N	Специальный боковой электрод							
U	∅ 14,0	11,2	Коническая плотная посадка	Hex 16,0	-Q	4 боковых электрода							
W	∅ 18,0	10,9	Коническая плотная посадка	Hex 20,8	-S	Специальное уплотнительное кольцо							
X	∅ 14,0	9,5	Уплотнительное кольцо	Hex 20,8	-T	3 боковых электрода							
Y	∅ 14,0	11,2	Коническая плотная посадка	Hex 16,0	-U	Тип с полуповерхностным разрядом							
				* Исключения TR5A-10, TR5A-13, TR5B-13, TR6B-10, TR6B-13, PTR5A-10, PTR5A-13 : Длина резьбы 25,0мм		Двойной шестигранник		IX-P	Свеча Iridium MAX				
				* Необходима головка с двойным шестигранником.		Шестигранник		LPG 1-8	Свечи зажигания LaserLine для газовых двигателей for gas engines				
				* FE, KE, KF, KG, MF : Увеличенная длина выступающего изолятора									

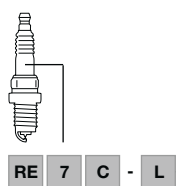

RE		7	C	-L		
Типы свечей зажигания		Калильное число	Конструкция	Межэлектродный зазор		
RE	Свеча для роторных двигателей	5	A,B,C... Suffix код	-L	Ведущая сторона	
SD	Свеча для роторных двигателей (полуповерхностный разряд и дополнительный зазор)	6			-T	Ведомая сторона
		7				
		8				
		9				
		10				
11						

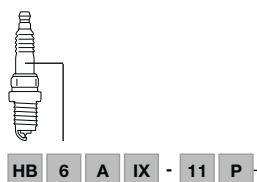

NB		6	A			IX	-11	P	
Типы свечей зажигания		Калильное число	Диаметр резьбы	Длина резьбы	Тип основания	Шестигранник	Межэлектродный зазор		
NB	HYBD (гибридный тип с 3 боковыми электродами)	4	A ∅ 14,0	20,5	Уплотнительное кольцо	Hex 16,0	IX	-8	0,8
		5	B ∅ 14,0	19,0	Уплотнительное кольцо	Hex 16,0		-9	0,9
		6					-10	1,0	
		7					-11	1,1	
		8					-13	1,3	

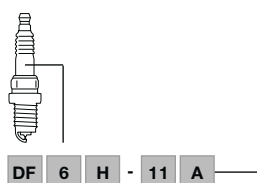

DF		6	H			-11	A	
Типы свечей зажигания		Калильное число	Диаметр резьбы	Длина резьбы	Тип основания	Шестигранник	Межэлектродный зазор	
DF	Свеча с повышенной надежностью зажигания (двойные тонкие электроды)	4	A ∅ 14,0	19,0	Уплотнительное кольцо	Hex 16,0	A,B,C... Suffix код	
DFH	Свеча с повышенной надежностью зажигания (DF + гибридный тип)	5	B ∅ 14,0	26,5	Уплотнительное кольцо	Hex 16,0		-8
		6	C ∅ 12,0	26,5	Уплотнительное кольцо	Hex 14,0	-9	0,9
		7	* DF6H-11A : Длина резьбы 28,0мм				-10	1,0
		8					-11	1,1
		9					-13	1,3
							-15	1,5

How to read our part number: Metal Glow Plugs

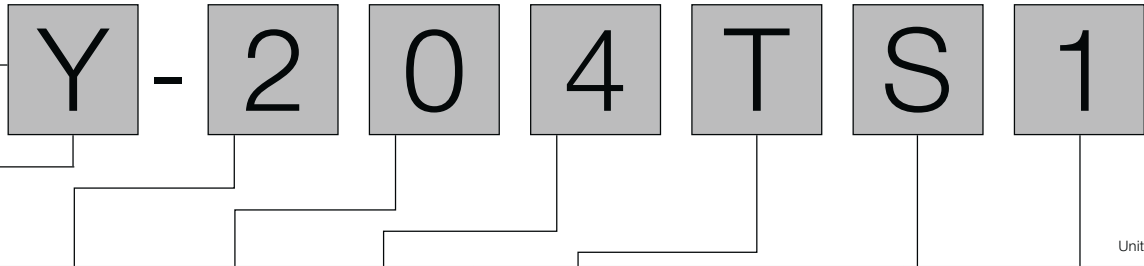

Unit : mm

Y		- 2		0		4		T		S		1	
	Model / Type	Thread size		Battery Voltage		Serial Number		Heating Characteristics		Glow tube material		Modification no.	
Y/YS	Sheathed type	1	10 mm	0-4	12 V	this figure is the serial number		A	AQGS type	S	Special		
YD	Sheathed, with double insulators	2	12 mm	5-9	24 V			J	SRM type	None	Standard		
		3	10 mm					K or no letter	Standard type				
		4	14 mm					R, M, U	QGS type				
		5	10 mm					T, V	Fast heating type				
		6	10 mm					Note: Y-7XXR, Y-9XXR are SRM Types					
		7	10 mm					Declaration					
		8	18 mm					AQGS Advanced Quick Glow System					
		9	12 mm					SRM Self Regulating Metal Glow Plug					
		*Y-109, Y-159 and Y-171 for Caterpillar Mitsubishi have a thread size of 3/8" (~9.5mm).						QGS Quick Glow System					

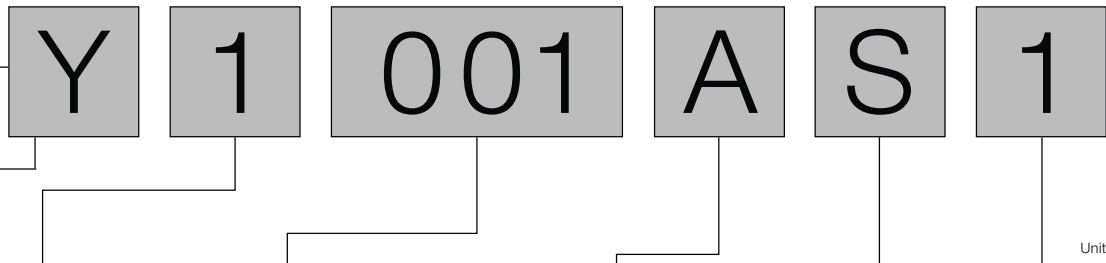

Unit : mm

Y		1		001		A		S		1	
	Model / Type	Thread size		Serial Number / Battery Voltage		Heating Characteristics		Glow tube material		Modification no.	
Y	Sheathed type	1	10 mm	001-899	12 V	A	AQGS type	S	Special		
		2	12 mm	900-999	24 V	J	SRM type	None	Standard		
		4	14 mm			K or no letter	Standard type				
		8	8 mm			R, M, U	QGS type				
		9	9 mm			T, V	Fast heating type				
						Declaration					
						AQGS Advanced Quick Glow System					
						SRM Self Regulating Metal Glow Plug					
						QGS Quick Glow System					

How to read our part number: Metal Glow Plugs

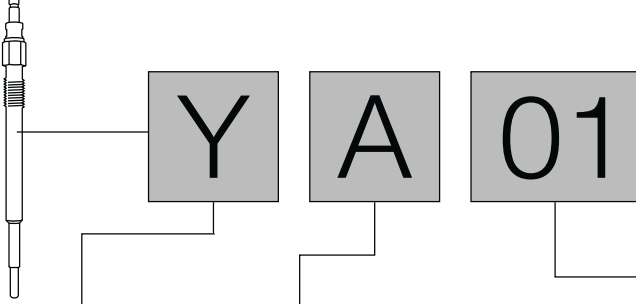

Unit : mm

Y	A	01
Model / Type	Heating Characteristics	Serial Number
Sheathed type Thread size: 8mm or 9mm	A Standard type	
	E QGS type or SRM type	

How to read our part number: Ceramic Glow Plugs

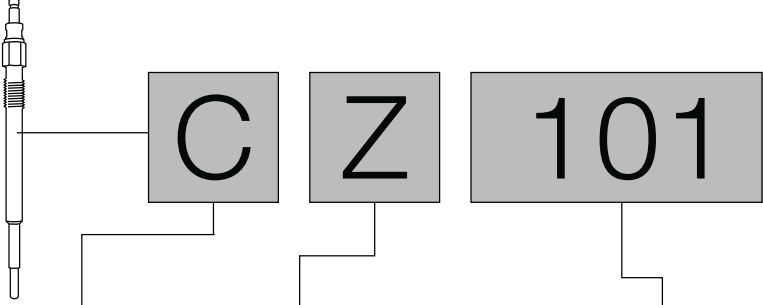

Unit : mm

C	Z	101
Model / Type	Heating Characteristics	Serial Number
Ceramic Glow Plug	X QGS Type Quick Glow System	
	Y SRC Type / HTC Self Regulating Ceramic Glow Plug	
	Z NHTC Type Quick Glow System	

Notes about the table

- △ = only for automobiles with immobilizer
- ◆ = only for automobiles without immobilizer

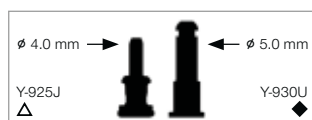

So lesen Sie unsere Teilenummer: Metall-Glühkerzen

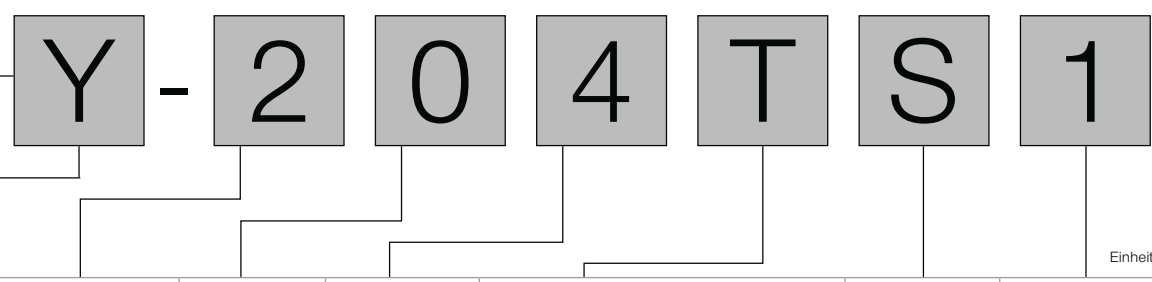

Einheit: mm

Y		-2		0		4		T		S		1	
Ausführung / Type		Gewindedurchmesser		Batteriespannung		Seriennummer		Glühcharakteristik		Glühstabmaterial		Modifikationsnummer	
Y/YS	Stabglühkerze	1	10 mm	0-4	12 V	Diese Ziffer ist die Seriennummer		A	AQGS Type	S	Spezial		
YD	Stabglühkerze mit doppeltem Isolato	2	12 mm	5-9	24 V			J	SRM Type	Keine	Standard		
		3	10 mm					K oder kein Buchstabe	Standard Type				
		4	14 mm					R, M, U	QGS Type				
		5	10 mm					T, V	Schnellstart Type				
		6	10 mm					Hinweis: Y-7XXR, Y-9XXR sind SRM Typen					
		7	10 mm					Erklärung					
		8	18 mm					AQGS Advanced Quick Glow System (Weiterentwickelte Schnellstartglühkerze)					
		9	12 mm					SRM Self Regulating metal Glow Plug (selbstregulierende Metall-Glühkerze)					
		*Y-109, Y-159, Y-171 für Caterpillar / Mitsubishi haben einen Gewindedurchmesser von 3/8" (ca. 9.5 mm)						QGS Quick Glow System (Schnellstartglühkerze)					

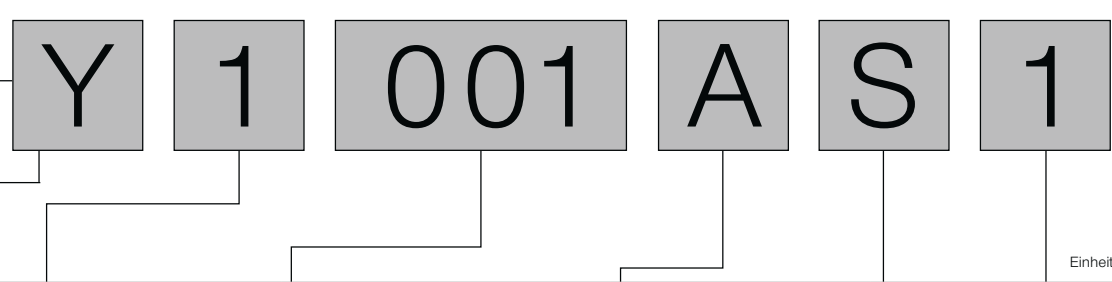

Einheit: mm

Y		1		001		A		S		1	
Ausführung / Type		Gewindedurchmesser		Seriennummer / Batteriespannung		Glühcharakteristik		Glühstabmaterial		Modifikationsnummer	
Y	Stabglühkerze	1	10 mm	001-899	12 V	A	AQGS Type	S	Spezial		
		2	12 mm	900-999	24 V	J	SRM Type	Keine	Standard		
		4	14 mm					K oder kein Buchstabe	Standard Type		
		8	8 mm					R, M, U	QGS Type		
		9	9 mm					T, V	Schnellstart Type		
								Erklärung			
								AQGS Advanced Quick Glow System (Weiterentwickelte Schnellstartglühkerze)			
								SRM Self Regulating metal Glow Plug (selbstregulierende Metall-Glühkerze)			
								QGS Quick Glow System (Schnellstartglühkerze)			

So lesen Sie unsere Teilenummer: Metall-Glühkerzen

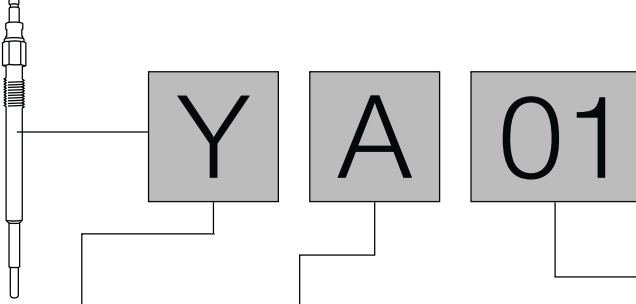

Einheit: mm

Y	A	01
Ausführung / Type	Glühcharakteristik	Seriennummer
Stabglühkerze Gewindedurchmesser: 8 mm oder 9 mm	A Standard Type	
	E QGS Type oder SRM Type	

So lesen Sie unsere Teilenummer: Keramik-Glühkerzen

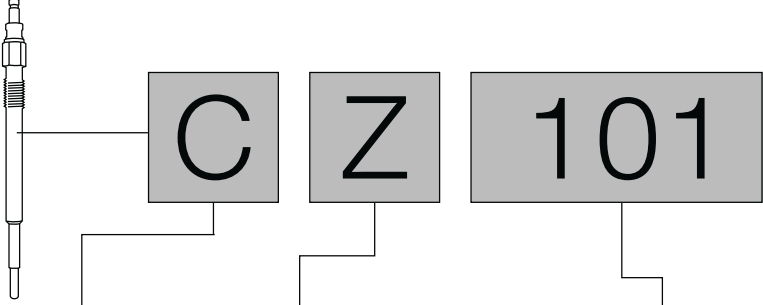

Einheit: mm

C	Z	101
Ausführung / Type	Glühcharakteristik	Seriennummer
Keramikglühkerze	X QGS Type Quick Glow System (Schnellglühsystem)	
	Y SRC Type / HTC Self Regulating Ceramic Glow Plug (selbstregulierende Keramik-Glühkerze)	
	Z NHTC Type Quick Glow System (Schnellglühsystem)	

Anmerkungen zur Tabelle

- △ = nur für Fahrzeuge mit Wegfahrsperre
- ◆ = nur für Fahrzeuge ohne Wegfahrsperre

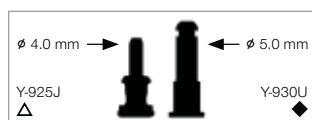

Comment lire notre numéro de pièce: Bougies de préchauffage en métal



Y - 2 0 4 T S 1

Unité : mm

Y		-2		0		4		T		S		1			
	Modèle / Type	Diamètre de filetage		Tension de batterie		Numéro de série		Caractéristique thermique		Type de matériau		Indice d'évolution			
Y/YS	Bougie de préchauffage à masse par le culot (Unipôle)	1	10 mm	0-4	12 V	Ce chiffre est le numéro de série		A	Type AQGS	S	Spécial				
		2	12 mm	5-9	24 V			J	Type SRM	Aucun	Standard				
		3	10 mm					K ou pas de lettre		Type standard					
		4	14 mm					R, M, U		Type QGS					
YD	Bougie de préchauffage isolée (dipôle)	5	10 mm					T, V		Type démarrage rapide					
		6	10 mm												
		7	10 mm												
		8	18 mm												
		9	12 mm												
		*Y-109, Y-159, Y-171 pour Caterpillar / Mitsubishi ont un diamètre de filetage de 3/8" (environ 9.5 mm)						Remarque : Y-7XXR et Y-9XXR sont des types SRM							
								Explication AQGS Advanced Quick Glow System (système de préchauffage rapide avancé) SRM Self Regulating Metal Glow Plug (bougie de préchauffage auto-régulante) QGS Quick Glow System (système de préchauffage rapide)							



Y 1 001 A S 1

Unité : mm

Y		1		001		A		S		1			
	Modèle / Type	Diamètre de filetage		Numéro de série / Tension de batterie		Caractéristique thermique		Type de matériau		Indice d'évolution			
Y	Bougie de préchauffage à masse par le culot	1	10 mm	001-899	12 V	A	Type AQGS	S	Spécial				
		2	12 mm	900-999	24 V	J	Type SRM	Aucun	Standard				
		4	14 mm			K ou pas de lettre		Type standard					
		8	8 mm			R, M, U		Type QGS					
		9	9 mm			T, V		Type démarrage rapide					
								Explication AQGS Advanced Quick Glow System (système de préchauffage rapide avancé) SRM Self Regulating Metal Glow Plug (bougie de préchauffage auto-régulante) QGS Quick Glow System (système de préchauffage rapide)					

Comment lire notre numéro de pièce: Bougies de préchauffage en métal



Y A 01

Unité : mm

Y	A	01
Modèle / Type	Caractéristique thermique	Numéro de série
Bougie de préchauffage à masse par le culot Thread size: 8mm or 9mm	A Type standard E Type QGS Type SRM	

Comment lire notre numéro de pièce: Bougies de préchauffage en céramique



C Z 101

Unité : mm

C	Z	101
Modèle / Type	Caractéristique thermique	Numéro de série
Bougie de préchauffage céramique	X QGS Type Quick Glow System (Système Quick Glow) Y SRC Type / HTC Self Regulating Ceramic Glow Plug (Bougie de préchauffage en céramique auto-régulatrice) Z NHTC Type Quick Glow System (Système Quick Glow)	

Remarques concernant le tableau

- △ = uniquement pour les véhicules avec anti-démarrage
- ◆ = uniquement pour les véhicules sans anti-démarrage

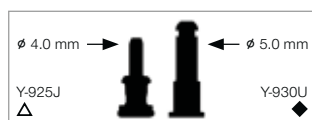

Come leggere il nostro numero del pezzo: candelette con bulbo metallico

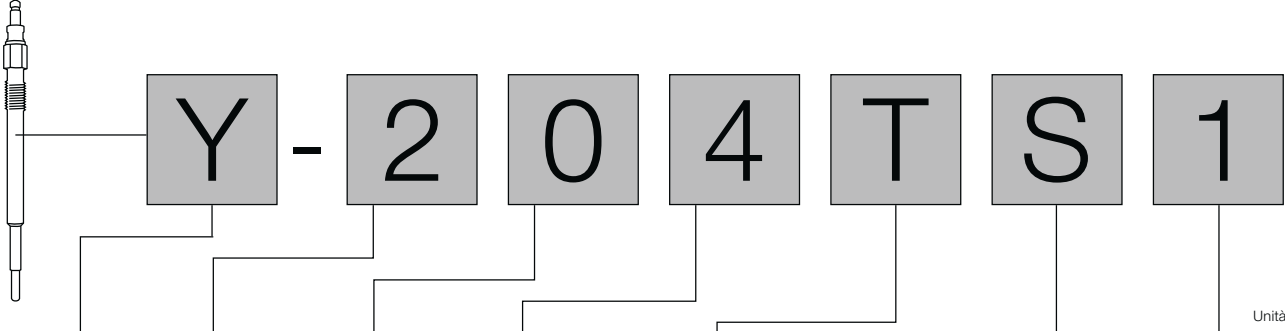

Unità: mm

Y		-2		0		4		T		S		1			
	Versione / Tipo	Diametro filettatura		Voltaggio		Numero di serie		Caratteristica di temperatura		Materiale del bulbo		Codice modifica			
Y/YS	Candeletta a bulbo metallico	1	10 mm	0-4	12 V	Questa cifra è il numero di serie		A	Tipo AQGS	S	Speciale				
		2	12 mm	5-9	24 V			J	Tipo SRM	Nessuno	Standard				
YD	Candeletta a bulbo metallico con doppio isolatore	3	10 mm					K o nessuna lettera							
		4	14 mm					R, M, U						Tipo QGS	
		5	10 mm					T, V						Tipo ad riscaldamento rapido	
		6	10 mm					Nota: I tipi Y-7XXR e Y-9XXR sono SRM							
		7	10 mm					Spiegazione							
		8	18 mm					AQGS						Advanced Quick Glow System	
		9	12 mm					SRM						Self Regulating Metal Glow Plug	
		*Y-109, Y-159, Y-171 per Caterpillar / Mitsubishi hanno un diametro della filettatura di 3/8" (circa 9,5 mm)		QGS		Quick Glow System									

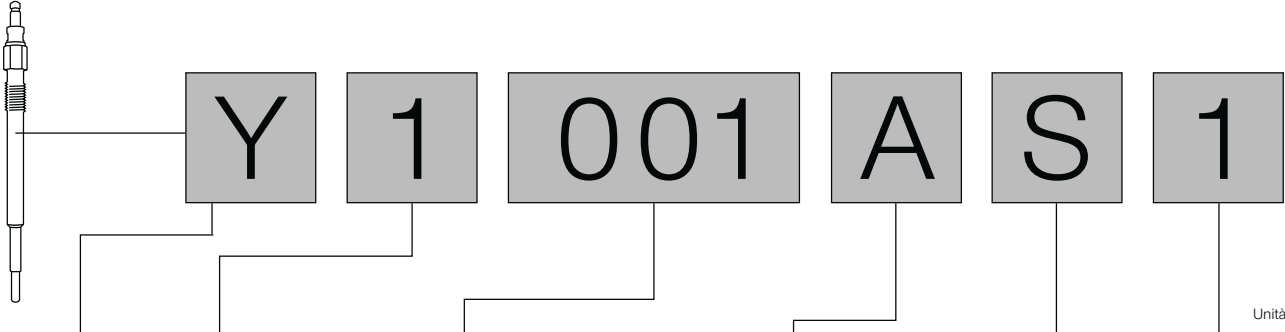

Unità: mm

Y		1		001		A		S		1			
	Versione / Tipo	Diametro filettatura		Numero di serie Tensione batteria		Caratteristica di temperatura		Materiale del bulbo		Codice modifica			
Y	Candeletta a spirale singola	1	10 mm	001-899	12 V	A	Tipo AQGS	S	Speciale				
		2	12 mm	900-999	24 V	J	Tipo SRM	Nessuno	Standard				
		4	14 mm			K o nessuna lettera							
		8	8 mm			R, M, U						Tipo QGS	
		9	9 mm			T, V						Tipo ad riscaldamento rapido	
						Spiegazione							
				AQGS		Advanced Quick Glow System							
				SRM		Self Regulating Metal Glow Plug							
				QGS		Quick Glow System							

Come leggere il nostro numero del pezzo: candelette con bulbo metallico



Unità: mm

Y	A	01
Versione / Tipo	Caratteristica di temperatura	Numero di serie
Candeletta a spirale singola Diametro filettatura: 8 mm o 9 mm	A Tipo standard	
	E Tipo QGS o tipo SRM	

Come leggere il nostro numero del pezzo: candelette con bulbo ceramico

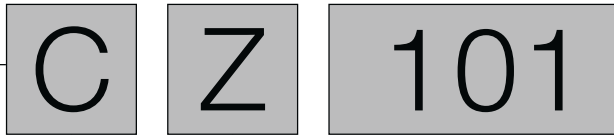

Unità: mm

C	Z	101
Versione / Tipo	Caratteristica di temperatura	Numero di serie
Candeletta con bulbo ceramico	X QGS Type Quick Glow System (Sistema a riscaldamento rapido)	
	Y SRC Type / HTC Self Regulating Ceramic Glow Plug (Candelette ceramiche autoregolanti)	
	Z NHTC Type Quick Glow System (Sistema a riscaldamento rapido)	

Note sulla tabella

- △ = solo per veicoli con immobilizer
- ◆ = solo per veicoli senza immobilizer

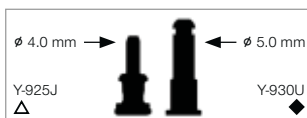

Cómo leer nuestros números de pieza: Calentadores metálicos



Y - 2 0 4 T S 1

Unidad: mm

Y		- 2		0		4		T		S		1	
	Modelo / Tipo	Diámetro de la rosca		Tensión de la batería		Número de serie		Características de incandescencia		Material de la varilla		Número de modificación	
Y/YS	Calentador Metálico	1	10 mm	0-4	12 V	Esta cifra indica el número de serie		A	Tipo AQGS	S	Especial		
		2	12 mm	5-9	24 V			J	Tipo SRM	Ninguno	Estándar		
YD	Calentador con doble aislador	3	10 mm					K o ninguna letra	Tipo estándar				
		4	14 mm										
		5	10 mm										
		6	10 mm										
		7	10 mm										
		8	18 mm										
		9	12 mm										
		*Y-109, Y-159, Y-171 para Caterpillar / Mitsubishi tienen un diámetro de rosca de 3/8" (aprox. 9.5 mm)						<p>Explicación</p> <p>AQGS Calentamiento inmediato, sistema avanzado</p> <p>SRM Metálico auto regulado</p> <p>QGS Calentamiento inmediato</p>					



Y 1 001 A S 1

Unidad: mm

Y		1		001		A		S		1	
	Modelo / Tipo	Diámetro de la rosca		Número de serie / Tensión de la batería		Características de incandescencia		Material de la varilla		Número de modificación	
Y	Calentador metálico	1	10 mm	001-899	12 V	A	Tipo AQGS	S	Especial		
		2	12 mm	900-999	24 V	J	Tipo SRM	Ninguno	Estándar		
		4	14 mm					K o ninguna letra	Tipo estándar		
		8	8 mm								
		9	9 mm								
								<p>Explicación</p> <p>AQGS Calentamiento inmediato, sistema avanzado</p> <p>SRM Metálico auto regulado</p> <p>QGS Calentamiento inmediato</p>			

Cómo leer nuestros números de pieza: Calentadores metálicos



Y A 01

Unidad: mm

Y	A	01
Modelo / Tipo	Características de incandescencia	Número de serie
Calentador Metálico Diámetro de la rosca: 8 mm o 9 mm	A Tipo estándar	
	E Tipo QGS otipo SRM	

Cómo leer nuestros números de pieza: Calentadores cerámicos



C Z 101

Unidad: mm

C	Z	101
Modelo / Tipo	Características de incandescencia	Número de serie
Candeleta con bulbo cerámico	X QGS Type Sistema Quick Glow	
	Y SRC Type / HTC Calentador cerámico autorregulado	
	Z NHTC Type Sistema Quick Glow	

Notas respecto a la tabla

- △ = solo para vehículos con inmovilizador
- ◆ = solo para vehículos sin inmovilizador

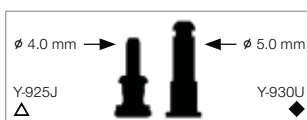

Hoe moet ons onderdeelnummer worden gelezen: Metalen gloeibougies



Eenheid: mm

Y		-2		0		4		T		S		1	
	Uitvoering / Type	Schroefdraaddiameter		Batterijspanning		Serienummer		Gloeikarakteristiek		Gloeistaafmateriaal		Modificatienummer	
Y/YS	Staafgloeibougie	1	10 mm	0-4	12 V	Dit getal is het serienummer		A	AQGS type	S	Speciaal		
YD	Staafgloeibougie met dubbele isolator	2	12 mm	5-9	24 V			J	SRM type	Geen	Standaard		
		3	10 mm					K of geen letter	Standaard type				
		4	14 mm					R, M, U	QGS type				
		5	10 mm					T, V	Snelstart type				
		6	10 mm					Opmerking: Y-7XXR en Y-9XXR zijn SRM- types					
		7	10 mm					Verklaring					
		8	18 mm					AQGS Advanced Quick Glow System					
		9	12 mm					SRM Self Regulating Metal Glow Plug					
		*Y-109, Y-159, Y-171 voor Caterpillar / Mitsubishi hebben een schroefdraaddiameter van 3/8" (ca. 9.5mm)						QGS Quick Glow System					



Eenheid: mm

Y		1		001		A		S		1	
	Uitvoering / Type	Schroefdraaddiameter		Serienummer / Batterijspanning		Gloeikarakteristiek		Gloeistaafmateriaal		Modificatienummer	
Y	Staafgloeibougie	1	10 mm	001-899	12 V	A	AQGS type	S	Speciaal		
		2	12 mm	900-999	24 V	J	SRM type	Geen	Standaard		
		4	14 mm			K of geen letter		Standaard type			
		8	8 mm			R, M, U		QGS type			
		9	9 mm			T, V		Snelstart type			
								Verklaring			
								AQGS Advanced Quick Glow System			
								SRM Self Regulating Metal Glow Plug			
								QGS Quick Glow System			

Hoe moet ons onderdeelnummer worden gelezen: Metalen gloeibougies

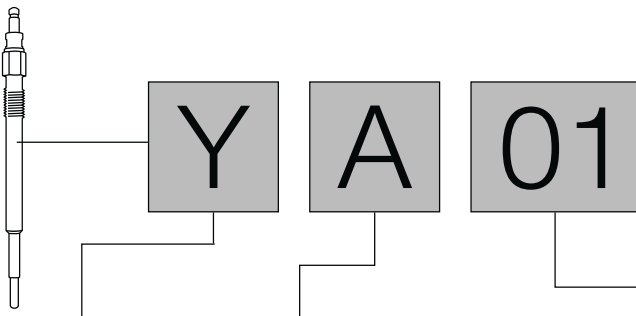

Eenheid: mm

Y	A	01
Uitvoering / Type	Gloeikarakteristiek	Serienummer
Staafgloeibougie Schroefdraaddiameter: 8 mm of 9 mm	A Standaard type	
	E QGS type of SRM type	

Hoe moet ons onderdeelnummer worden gelezen: Keramische gloeibougies

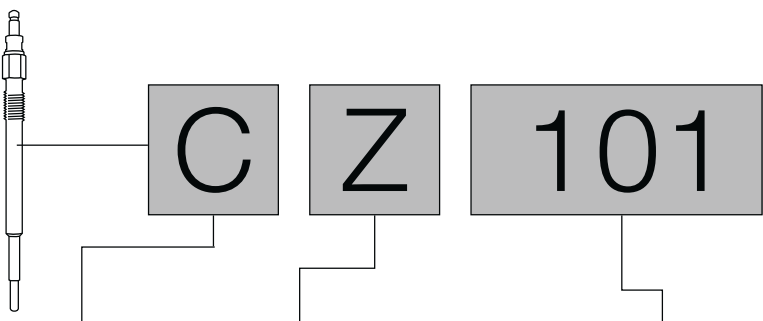

Eenheid: mm

C	Z	101
Uitvoering / Type	Gloeikarakteristiek	Serienummer
Keramische gloeibougies	X QGS Type Quick Glow System	
	Y SRC Type / HTC Self Regulating Ceramic Glow Plug (Zelfregelende keramische gloeibougie)	
	Z NHTC Type Quick Glow System	

Opmerkingen bij de tabel

- △ = uitsluitend voor voertuigen met wegrijbeveiliging
- ◆ = uitsluitend voor voertuigen zonder wegrijbeveiliging

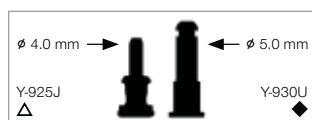

Como ler o nosso número de peça: Vela de Incandescência Metálica



Y - 2 0 4 T S 1

Unidade : mm

Y		-2	0	4	T		S		1
Acabamento / Tipo	Tamanho da rosca	Voltagem da bateria		Número de série	Característica de incandescência		Material do tubo		Número de alteração do projecto
Y/YS	Vela incandescente	1	10 mm	0-4	12 V	A	Tipo AQGS	S	Especial
YD	Vela incandescente com isolador duplo	2	12 mm	5-9	24 V	J	Tipo SRM	Nenhum	Padrão
		3	10 mm			K ou nenhum letra	Tipo padrão		
		4	14 mm			R, M, U	Tipo QGS		
		5	10 mm			T, V	Tipo arranque rápido		
		6	10 mm			Nota: Y-7XXR e Y-9XXR são tipos SRM			
		7	10 mm			Explicação			
		8	18 mm			AQGS Advanced Quick Glow System (Sistema avançado de pré-aquecimento rápido)			
		9	12 mm			SRM Self Regulating Metal Glow Plug (Tipo autoregulado)			
		*Y-109, Y-159, Y-171 para Caterpillar / Mitsubishi possuem diâmetro de rosca de 3/8" (aprox. 9,5mm)				QGS Quick Glow System (Sistema de pré-aquecimento rápido)			



Y 1 001 A S 1

Unidade : mm

Y		1	001		A		S		1
Acabamento / Tipo	Tamanho da rosca	Número de série / Voltagem da bateria		Característica de incandescência		Material do tubo		Número de alteração do projecto	
Y	Vela incandescente	1	10 mm	001-899	12 V	A	Tipo AQGS	S	Especial
		2	12 mm	900-999	24 V	J	Tipo SRM	Nenhum	Padrão
		4	14 mm			K ou nenhum letra	Tipo padrão		
		8	8 mm			R, M, U	Tipo QGS		
		9	9 mm			T, V	Tipo arranque rápido		
						Explicação			
						AQGS Advanced Quick Glow System (Sistema avançado de pré-aquecimento rápido)			
						SRM Self Regulating Metal Glow Plug (Tipo autoregulado)			
						QGS Quick Glow System (Sistema de pré-aquecimento rápido)			

Como ler o nosso número de peça: Vela de Incandescência Metálica



Y A 01

Unidade : mm

Y	A	01
Acabamento / Tipo	Característica de incandescência	Número de série
Vela incandescente Diâmetro da rosca: 8mm ou 9mm	A Tipo padrão	
	E Tipo QGS outipo SRM	

Como ler o nosso número de peça: Velas de Incandescência em Cerâmica



C Z 101

Unidade : mm

C	Z	101
Acabamento / Tipo	Característica de incandescência	Número de série
Vela de incandescência cerâmica	X QGS Type Quick Glow System (Sistema de Incandescência Rápida)	
	Y SRC Type / HTC Self Regulating Ceramic Glow Plug (Vela de Incandescência Cerâmica Autorreguladora)	
	Z NHTC Type Quick Glow System (Sistema de Incandescência Rápida)	

Anotações à tabela

- △ = apenas para veículos com imobilizador
- ◆ = apenas para veículos sem imobilizador

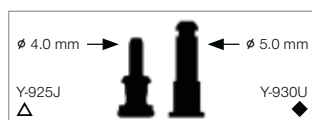

Πώς να ερμηνεύετε τους κωδικούς μας: Μεταλλικοί προθερμαντήρες



Y - 2 0 4 T S 1

Μονάδα: mm

Y		-2		0		4		T		S		1					
Εκτέλεση / Τύπος		Διάμετρος σπειρώματος		Τάση μπαταρίας		Τάση μπαταρίας		Χαρακτηριστικά πυράκτωσης		Υλικό ράβδου πυράκτωσης		Αριθμός Διάμετρος τροποποίησης					
Y/YS	Προθερμαντήρας ράβδου	1	10 mm	0-4	12 V	Αυτό το ψηφίο αποτελεί τον αριθμό σειράς	A	Τύπος AQGS	S	Ειδικός							
		2	12 mm	5-9	24 V		J	Τύπος SRM	Κανένας	Στάνταρ							
YD	Προθερμαντήρας ράβδου με διπλό μονωτήρα	3	10 mm				K ή κανένα γράμμα	Στάνταρ τύπος									
		4	14 mm				R, M, U	Τύπος QGS									
		5	10 mm				T, V	Τύπος γρήγορης εκκίνησης									
		6	10 mm				Σημείωση: Y-7XXR και Y-9XXR αποτελούν τύπους SRM										
		7	10 mm				Επεξήγηση										
		8	18 mm				AQGS Advanced Quick Glow System										
		9	12 mm				SRM Self Regulating Metal Glow Plug										
		*Y-109, Y-159, Y-171 για Caterpillar / Mitsubishi έχουν μία διάμετρος σπειρώματος από 3/8" (περ. 9,5 mm)				QGS Quick Glow System											



Y 1 001 A S 1

Μονάδα: mm

Y		1		001		A		S		1	
Εκτέλεση / Τύπος		Διάμετρος σπειρώματος		Αριθμός σειράς / Τάση μπαταρίας		Χαρακτηριστικά πυράκτωσης		Υλικό ράβδου πυράκτωσης		Αριθμός Διάμετρος τροποποίησης	
Y	Προθερμαντήρας ράβδου	1	10 mm	001-899	12 V	A	Τύπος AQGS	S	Ειδικός		
		2	12 mm	900-999	24 V	J	Τύπος SRM	Κανένας	Στάνταρ		
		4	14 mm			K ή κανένα γράμμα	Στάνταρ τύπος				
		8	8 mm			R, M, U	Τύπος QGS				
		9	9 mm			T, V	Τύπος γρήγορης εκκίνησης				
						Επεξήγηση					
				AQGS Advanced Quick Glow System		SRM Self Regulating Metal Glow Plug		QGS Quick Glow System			

Πώς να ερμηνεύετε τους κωδικούς μας: Μεταλλικοί προθερμαντήρες



Y A 01

Μονάδα: mm

Y	A	01
Εκτέλεση / Τύπος	Χαρακτηριστικά πυράκτωσης	Τάση μπαταρίας
Προθερμαντήρας ράβδου Διάμετρος σπειρώματος: 8 mm ή 9 mm	A Στάνταρ τύπος E Τύπος QGS ή Τύπος SRM	

Πώς να ερμηνεύετε τους κωδικούς μας: Κεραμικοί προθερμαντήρες



C Z 101

Μονάδα: mm

C	Z	101
Εκτέλεση / Τύπος	Χαρακτηριστικά πυράκτωσης	Τάση μπαταρίας
Κεραμικός προθερμαντήρας	X Τύπος QGS Quick Glow System (Σύστημα ταχείας πυράκτωσης) Y Τύπος SRC / HTC Self Regulating Ceramic Glow Plug (Κεραμικός αυτορυθμιζόμενος προθερμαντήρας) Z Τύπος NHTC Quick Glow System (Σύστημα ταχείας πυράκτωσης)	

Παρατηρήσεις για τον πίνακα

- Δ = μόνο για οχήματα με Immobilizer
- ◆ = μόνο για οχήματα χωρίς Immobilizer

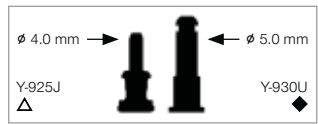

Parça numaramızın okunma şekli: Metal Kızdırma Bujileri

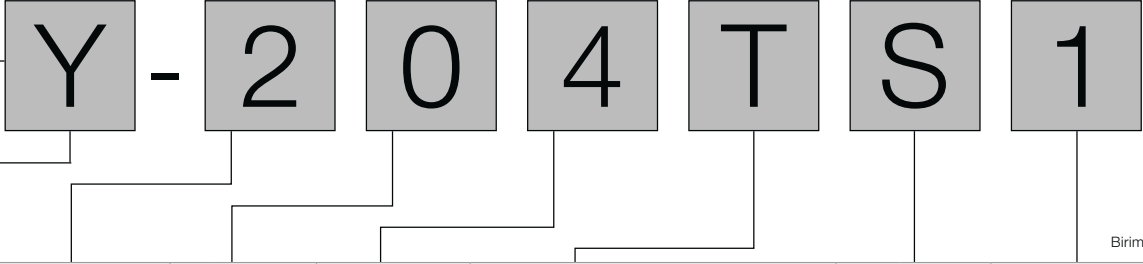

Birim: mm

Y		-2		0		4		T		S		1	
Model / Tip	Diş çapı	Akü gerilimi		Seri numarası		Kızdırma karakteristiği		Kızdırma çubuk materyali		Modifikasyon numarası			
Y/YS	Çubuk tipi	1	10 mm	0-4	12 V	Bu rakam seri numarasıdır		A	AQGS tipi	S	Özel		
	kızdırma bujisi	2	12 mm	5-9	24 V			J	SRM tipi	Yok	Standart		
YD	Çift izolatörlü çubuk tipi kızdırma bujisi	3	10 mm					K veya harfsiz	Standart tip				
		4	14 mm										
		5	10 mm										
		6	10 mm										
		7	10 mm										
		8	18 mm										
		9	12 mm										
*Y-109, Y-159, Y-171 kızdırma bujilerin diş çapı Caterpillar / Mitsubishi için 3/8" (yaklaşık 9,5mm)							Açıklama AQGS Advanced Quick Glow System SRM Self Regulating Metal Glow Plug QGS Quick Glow System						

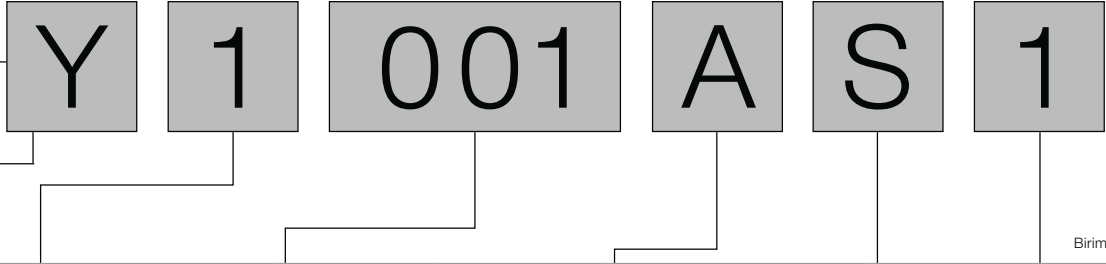

Birim: mm

Y		1		001		A		S		1	
Model / Tip	Diş çapı	Seri numarası / Akü gerilimi		Kızdırma karakteristiği		Kızdırma çubuk materyali		Modifikasyon numarası			
Y	Çubuk tipi	1	10 mm	001-899	12 V	A	AQGS tipi	S	Special		
	kızdırma bujisi	2	12 mm	900-999	24 V	J	SRM tipi	None	Standart		
		4	14 mm					K veya harfsiz	Standart tip		
		8	8 mm								
		9	9 mm								
							Açıklama AQGS Advanced Quick Glow System SRM Self Regulating Metal Glow Plug QGS Quick Glow System				

Parça numaramızın okunma şekli: Metal Kızdırma Bujileri



Y A 01

Birim: mm

Y	A	01
Model / Tip	Kızdırma karakteristiği	Seri numarası
Çubuk tipi kızdırma bujisi Diş çapı: 8mm veya 9mm	A Standart tip	
	E QGS tipi veya SRM tipi	

Parça numaramızın okunma şekli: Seramik Kızdırma Bujileri



C Z 101

Birim: mm

C	Z	101
Model / Tip	Kızdırma karakteristiği	Seri numarası
Seramik kızdırma bujisi	X QGS tipi Quick Glow System (Hızlı Kızdırma Sistemi)	
	Y SRC tipi / HTC Self Regulating Ceramic Glow Plug (Kendi Kendini Ayarlayan Seramik Kızdırma Bujisi)	
	Z NHTC tipi Quick Glow System (Hızlı Kızdırma Sistemi)	

Tablo notu

- △ = sadece Immobilizer'li araçlar için
◆ = sadece Immobilizer'li olmayan araçlar için

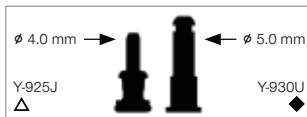

Jak odczytać numer części: Metalowe świece żarowe



Y - 2 0 4 T S 1

Jednostka: mm

Y		-2	0	4	T		S		1
Wykonanie / type	Średnica gwintu	Napięcie robocze		Numer seryjny	Charakterystyka żarzenia		Materiał prełu grzewczego		Numer modyfikacji
Y/YS	Świeca żarowa jednobiegunowa	1 10 mm	0-4 12 V	Ta cyfra oznacza numer seryjny	A	Typ AQGS	S	Specjalne	
		2 12 mm	5-9 24 V		J	Typ SRM	Brak	Standardowe	
YD	Świece żarowe dwubiegunowe	3 10 mm			K lub brak litery	Typ standardowy			
		4 14 mm			R, M, U	Typ QGS			
		5 10 mm			T, V	Typ szybkiego rozruchu			
		6 10 mm			Uwaga: Y-7XXR i Y-9XXR to produkty typu SRM				
		7 10 mm			Objaśnienia:				
		8 18 mm			AQGS Advanced Quick Glow System (Zaawansowany system szybkiego żarzenia)				
		9 12 mm			SRM Self Regulating Metal Glow Plug (Typ samoregulacyjny)				
		*Y-109, Y-159, Y-171 dla Caterpillar/Mitsubishi posiadają średnicę gwintu 3/8" (ok. 9,5mm)				QGS Quick Glow System (System szybkiego żarzenia)			



Y 1 001 A S 1

Jednostka: mm

Y		1	001		A		S		1
Wykonanie / type	Średnica gwintu	Numer seryjny / Napięcie robocze		Charakterystyka żarzenia		Materiał prełu grzewczego		Numer modyfikacji	
Y	Świeca żarowa jednobiegunowa	1 10 mm	001-899	12 V	A	Typ AQGS	S	Specjalne	
		2 12 mm	900-999	24 V	J	Typ SRM	Brak	Standardowe	
	4 14 mm				K lub brak litery	Typ standardowy			
	8 8 mm				R, M, U	Typ QGS			
	9 9 mm				T, V	Typ szybkiego rozruchu			
				Objaśnienia:					
				AQGS Advanced Quick Glow System (Zaawansowany system szybkiego żarzenia)					
				SRM Self Regulating Metal Glow Plug (Typ samoregulacyjny)					
				QGS Quick Glow System (System szybkiego żarzenia)					

Jak odczytać numer części: Metalowe świece żarowe



Y A 01

Jednostka:
mm

Y	A	01
Wykonanie / type	Charakterystyka żarzenia	Numer seryjny
Świeca żarowa jednobiegunowa Średnica gwintu: 8mm lub 9mm	A Typ standardowy	
	E Typ QGS lub typ SRM	

Jak odczytać numer części: Ceramiczne świece żarowe



C Z 101

Jednostka:
mm

C	Z	101
Wykonanie / type	Charakterystyka żarzenia	Numer seryjny
Świece żarowe ceramiczne	X QGS Type Quick Glow System System szybkiego żarzenia (QGS)	
	Y SRC Type / HTC Self Regulating Ceramic Glow Plug (Samoregulująca się ceramiczna świeca żarowa)	
	Z NHTC Type Quick Glow System System szybkiego żarzenia (QGS)	

Uwagi do tabeli

- △ = tylko do pojazdów z blokadą przeciwuruchomienną
- ◆ = tylko do pojazdów bez blokady przeciwuruchomienną

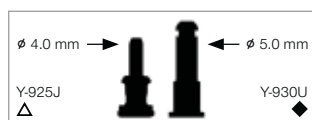

Jak číst naše číslo dílu: Kovové žhavicí svíčky



Y - 2 0 4 T S 1

Jednotky: mm

Y		-2		0		4		T		S		1			
	Provedení / typ	Průměr závitů		Napětí akumulátoru		Sériové číslo		Charakteristika žhavení		Materiál žhavicí tyčky		Číslo modifikace			
Y/YS	Tyčová žhavicí svíčka	1	10 mm	0-4	12 V	Toto číslo je sériové číslo		A	AQGS typ	S	Speciální				
		2	12 mm	5-9	24 V			J	SRM typ	Žádný	Standardní				
YD	Tyčová žhavicí svíčka s dvojitým izolátorem	3	10 mm					K nebo žádné písmeno							
		4	14 mm					Standardní typ							
		5	10 mm					R, M, U						QGS typ	
		6	10 mm					T, V						Typ rychlý start	
		7	10 mm					Poznámka: Y-7XXR a Y-9XXR jsou typy SRM							
		8	18 mm					Vysvětlení							
		9	12 mm					AQGS						Advanced Quick Glow System	
		*Y-109, Y-159, Y-171 pro Caterpillar / Mitsubishi mají průměr závitů 3/8" (cca 9,5mm)		SRM		Self Regulating Metal Glow Plug		QGS		Quick Glow System					



Y 1 001 A S 1

Jednotky: mm

Y		1		001		A		S		1					
	Provedení / typ	Průměr závitů		Sériové číslo / Napětí akumulátoru		Charakteristika žhavení		Materiál žhavicí tyčky		Číslo modifikace					
Y	Tyčová žhavicí svíčka	1	10 mm	001-899	12 V			A	AQGS typ	S	Speciální				
		2	12 mm	900-999	24 V			J	SRM typ	Žádný	Standardní				
		4	14 mm					K nebo žádné písmeno							
		8	8 mm					R, M, U						QGS typ	
		9	9 mm					T, V						Typ rychlý start	
		Vysvětlení						AQGS						Advanced Quick Glow System	
				SRM		Self Regulating Metal Glow Plug		QGS		Quick Glow System					

Jak číst naše číslo dílu: Kovové žhavicí svíčky



Jednotky: mm

Y	A	01
Provedení / typ	Charakteristika žhavení	Sériové číslo
Tyčová žhavicí svíčka Průměr závitu: 8 mm nebo 9 mm	A Standardní typ E QGS typ nebo SRM typ	

Jak číst naše číslo dílu: Keramické žhavicí svíčky

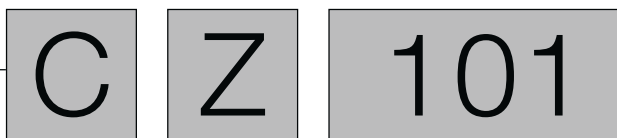

Jednotky: mm

C	Z	101
Provedení / typ	Charakteristika žhavení	Sériové číslo
Keramická žhavicí svíčka	X QGS Type Systém rychlého žhavení Y SRC Type / HTC Samoregulační keramická žhavicí svíčka Z NHTC Type Systém rychlého žhavení	

Poznámky k tabulce

- △ = pouze pro vozidla s imobilizérem
- ◆ = pouze pro vozidla bez imobilizéru

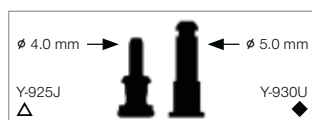

Hogyan kell leolvasni a cikkszámot: Fémházas izzítógyertyák

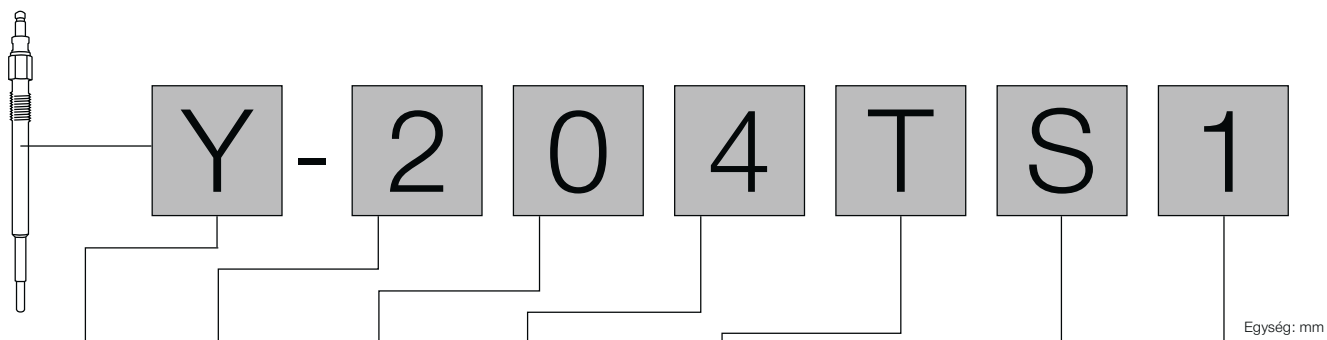

Y		- 2	0	4	T		S		1
	kivitel / típus	menet átmérő	akku feszültség	sorozatszám	izzítási karakterisztika		izzórúd anyaga		változtatási
Y/YS	Rúd izzítógyertya	1 10 mm	0-4 12 V	A szám a sorozatszám	A	AQGS típus	S	Speciális	
YD	Rúd izzítógyertya kettős szigetelével	2 12 mm	5-9 24 V		J	SRM típus	Egyik sem	Standard	
		3 10 mm		K vagy betű nélkül	Normál típus				
		4 14 mm		R, M, U	QGS típus				
		5 10 mm		T, V	Gyorsindító típus				
		6 10 mm		Megjegyzés: Y-7XXR és Y-9XXR SRM típusúak Magyarázat					
		7 10 mm		AQGS	Advanced Quick Glow System				
		8 18 mm		SRM	Self Regulating Metal Glow Plug				
		9 12 mm		QGS	Quick Glow System				
		*Y-109, Y-159, Y-171 Caterpillar / Mitsubishi típusokhoz menetük átmérője 3/8" (kb. 9,5 mm)							

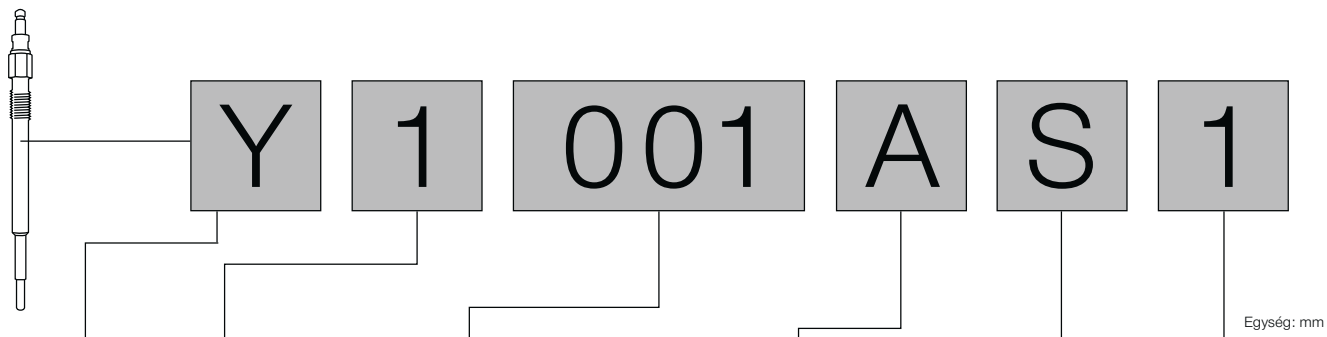

Y		1	001		A		S		1
	kivitel / típus	menet átmérő	sorozatszám / akku feszültség		izzítási karakterisztika		izzórúd anyaga		változtatási
Y	Rúd izzítógyertya	1 10 mm	001-899	12 V	A	AQGS típus	S	Speciális	
		2 12 mm	900-999	24 V	J	SRM típus	Egyik sem	Standard	
		4 14 mm			K vagy betű nélkül	Normál típus			
		8 8 mm			R, M, U	QGS típus			
		9 9 mm			T, V	Gyorsindító típus			
					Magyarázat				
					AQGS	Advanced Quick Glow System			
					SRM	Self Regulating Metal Glow Plug			
					QGS	Quick Glow System			

Hogyan kell leolvasni a cikkszámot: Fémházas izzítógyertyák



Y

A

01

Egység: mm

Y	A	01
kivitel / típus	izzítási karakterisztika	sorozatszám
Rúd izzítógyertya Menet átmérő: 8 vagy 9 mm	A Normál típus	
	E QGS típus vagy SRM típus	

Hogyan kell leolvasni a cikkszámot: Kerámia izzítógyertyák



C

Z

101

Egység: mm

C	Z	101
kivitel / típus	izzítási karakterisztika	sorozatszám
Kerámia izzítógyertya	X QGS típus Quick Glow System (Gyorsizzító rendszer)	
	Y SRC típus / HTC Self Regulating Ceramic Glow Plug (Önszabályozó kerámia izzítógyertya)	
	Z NHTC típus Quick Glow System (Gyorsizzító rendszer)	

Megjegyzések a táblázathoz

- △ = csak immobiliseres autókhoz
- ◆ = csak immobiliser nélküli autókhoz

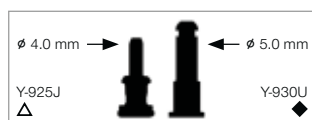

Что означает код детали: Металлические свечи накаливания



Единица измерения : мм

Y		-2		0		4		T		S		1	
Исполнение / Тип		Диаметр резьбы		Напряжение батареи		Номер серии		Характеристика накаливания		Материал штифта накаливания		Номер модификации	
Y/YS	Штифтовая свеча накаливания	1	10 мм	0-4	12 В	Эта цифра является номером серии	A	Тип AQGS	S	Специальная			
		2	12 мм	5-9	24 В		J	Тип SRM	Отсутствует	Стандартная			
		3	10 мм				К или без буквы	Стандартный тип					
YD	Штифтовая свеча накаливания с некорпусным заземлением	4	14 мм				R, M, U	Тип QGS					
		5	10 мм				T, V	Тип с ускоренным нагревом					
		6	10 мм				Примечание: Y-7XXR и Y-9XXR – свечи типа SRM						
		7	10 мм				Пояснение						
		8	18 мм				AQGS Advanced Quick Glow System (Улучшенная система быстрого накаливания)						
		9	12 мм				SRM Self Regulating Metal Glow Plug (Саморегулирующийся тип, металл)						
		*Y-109, Y-159, Y-171 для CATERPILLAR имеют диаметр резьбы 3/8" (ок. 9.5 мм)						QGS Quick Glow System (Система быстрого накаливания)					



Единица измерения : мм

Y		1		001		A		S		1	
Исполнение / Тип		Диаметр резьбы		Номер серии / Напряжение батареи		Характеристика накаливания		Материал штифта накаливания		Номер модификации	
Y	Sheathed type	1	10 мм	001-899	12 В	A	Тип AQGS	S	Специальная		
		2	12 мм	900-999	24 В	J	Тип SRM	Отсутствует	Стандартная		
		4	14 мм			К или без буквы	Стандартный тип				
		8	8 мм			R, M, U	Тип QGS				
		9	9 мм			T, V	Тип с ускоренным нагревом				
						Пояснение					
						AQGS Advanced Quick Glow System (Улучшенная система быстрого накаливания)					
						SRM Self Regulating Metal Glow Plug (Саморегулирующийся тип, металл)					
						QGS Quick Glow System (Система быстрого накаливания)					

Что означает код детали: Металлические свечи накаливания



Y A 01

Единица измерения : мм

Y	A	01
Исполнение / Тип	Характеристика накаливания	Номер серии
Штифтовая свеча накаливания Диаметр резьбы: 8 мм или 9 мм	A Стандартный тип	
	E Тип QGS или Тип SRM	

Что означает код детали: Керамические свечи накаливания



C Z 101

Единица измерения : мм

C	Z	101
Исполнение / Тип	Характеристика накаливания	Номер серии
Керамическая свеча накаливания	X QGS Type Quick Glow System (Система быстрого накаливания)	
	Y SRC Type / HTC Self Regulating Ceramic Glow Plug (Саморегулирующаяся керамическая свеча накаливания)	
	Z NHTC Type Quick Glow System (Система быстрого накаливания)	

Примечания к таблице

- △ = только для автомобилей с иммобилайзером
- ◆ = только для автомобилей без иммобилайзера

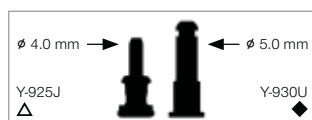



IMPORTANT TIPS FOR THE INSTALLATION OF SPARK PLUGS

A torque wrench is required for the professional installation of a spark plug. Even for professionals the estimation of the tightening torque is nearly impossible. That is because a torque can be calculated from two sizes which are multiplied by one another: the force which is applied to the respective centre of rotation and the length of the

handle. Most spark plug failures can be traced back to an incorrect tightening torque. If it is set too low, there is a risk of compression losses and overheating. A break of the insulator or middle electrode as a result of vibrations is also feasible. If the tightening torque is set too high, the spark plug can snap off. The casing can also expand

or warp. Heat dissipation zones are disrupted, overheating and melting of the electrodes or even engine damage can occur.

Spark plug tightening torques

The required tightening torque depends on seat type, thread diameter and cylinder head material. Please take care of the tightening torques or angles, whenever these are printed on the packaging material!

1 Seat type

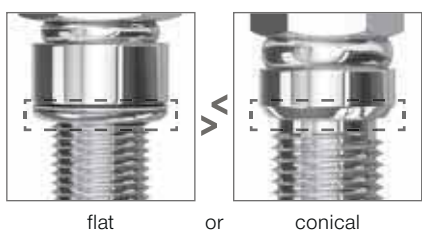

flat or conical

2 Thread diameter



3 Cylinder head material

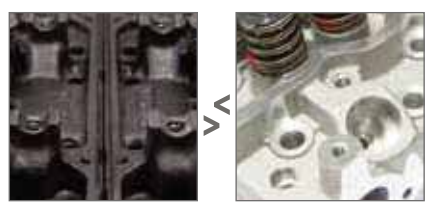

Cast iron or Aluminium

1	Seat type	Spark plug with a flat seat (with seal)				Spark plug with a conical seat	
	2 Thread Ø	10 mm	12 mm	14 mm	18 mm	12/14 mm	18 mm
3	Cast iron head	10-15 Nm	15-25 Nm	25-35 Nm	35-45 Nm	15-25 Nm	20-30 Nm
	Aluminium head	10-12 Nm	15-20 Nm	25-30 Nm	35-40 Nm	10-20 Nm	20-30 Nm

Alternative: Angle of rotation details

The respective angle of rotation can be found on the spark plug packaging. (Exception: racing plugs – only torque method)

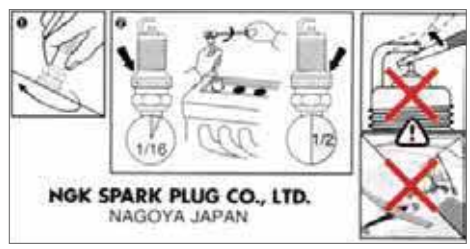



IMPORTANT TIPS FOR THE REMOVAL AND INSTALLATION OF GLOW PLUGS

1 Removal / Breakaway torque



When changing glow plugs you must always use the correct torque, so that the breakaway torque is not exceeded, if not there is danger of tear-off.

Glow plug breakaway torque

Ø Thread	M8	M9	M10	M12
Breakaway torque	20 Nm	30 Nm	40 Nm	50 Nm

Note: Other manufacturers often have, due to the varying thread materials, lower breakaway torque values. For this reason, you should reduce of a further 5 Nm the value, whenever the glow plug manufacturer is unknown.

2 Tips on removal issues

If an immediate removal is not urgent, we suggest proceeding as follows:

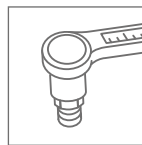
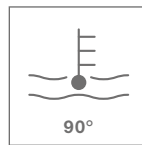

- > Sprinkle the glow plug seat on the transition to the cylinder head with synthetic motor oil.
- > Let absorb for a couple of days and move the vehicle.
- > Remove the glow plugs with the engine at operating temperature paying attention to the breakaway torques using a suitable torque wrench.

3 Cleaning



Before installing new glow plugs oil and soot residue should be removed from the glow plug hole with a greased reamer.

4 Glow plug installation / tightening torques

Metal rod glow plugs						Ceramic glow plugs	
Ø Thread	M8	M9	M10	M12	M14	M8	M10
Tightening torque	8,5Nm	11Nm	15Nm	23Nm	23Nm	10Nm	18Nm
Tolerance in %	+/- 10	+/- 10	+/- 10	+/- 10	+/- 10	+/- 10	+/- 10

Connecting nut		
Ø Thread	M4	M5
Tightening torque	0,8–1,5Nm	3,0–4,0Nm
Tolerance in %	+/- 10	+/- 10

! Please take care of the tightening torques, whenever these are printed on the packaging material! Glow plugs will function properly only when tightened with the correct tightening torque!



WICHTIGE TIPPS ZUM EINBAU VON ZÜNDKERZEN

Für die fachgerechte Montage einer Zündkerze ist ein Drehmomentschlüssel erforderlich. Denn selbst für Werkstattprofis ist das „Schätzen“ des Anzugsdrehmomentes nahezu unmöglich. Das liegt daran, dass sich ein Drehmoment aus zwei Größen errechnet, die miteinander multipliziert werden: der Kraft, die auf den jeweiligen Drehpunkt

einwirkt, und der Länge des Hebels. Die meisten Zündkerzenausfälle gehen auf ein falsches Anzugsdrehmoment zurück. Wird es zu niedrig gewählt, drohen Kompressionsverluste und Überhitzung. Auch ein Bruch von Isolator oder Mittelelektrode infolge von Vibrationen ist denkbar. Wird das Drehmoment zu hoch gewählt, kann es zum Abreißen

der Zündkerze führen. Auch kann das Gehäuse sich dehnen oder verdrehen. Die Wärmeabflusszonen werden gestört, es drohen Überhitzung und Verschmelzung der Elektroden bis hin zum Motorschaden.

Anzugsdrehmomente Zündkerzen

Das erforderliche Anzugsdrehmoment ist abhängig vom Sitztyp, Gewindedurchmesser und dem Zylinderkopfmaterial. Bitte beachten Sie die Anzugsdrehmomente oder -Winkel, wenn diese auf der Verpackung angegeben sind!

1 Sitztyp

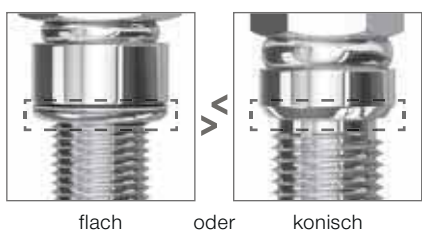

flach oder konisch

2 Gewindedurchmesser



3 Zylinderkopfmaterial

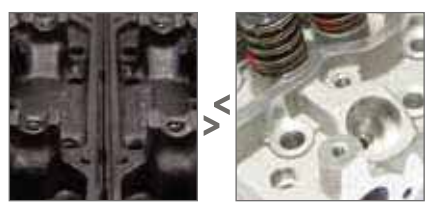

Gusseisen oder Aluminium

1	Sitztyp	Zündkerze mit flachem Sitz (mit Dichtung)				Zündkerze mit konischem Sitz	
	Gewinde Ø	10 mm	12 mm	14 mm	18 mm	12/14 mm	18 mm
3	Gusseisenkopf	10-15 Nm	15-25 Nm	25-35 Nm	35-45 Nm	15-25 Nm	20-30 Nm
	Aluminiumkopf	10-12 Nm	15-20 Nm	25-30 Nm	35-40 Nm	10-20 Nm	20-30 Nm

Alternativ: Drehwinkel-Angaben

Der jeweilige Drehwinkel ist auf der Zündkerzenverpackung zu finden. (Ausnahme: Rennzündkerzen - nur Drehmomentmethode)

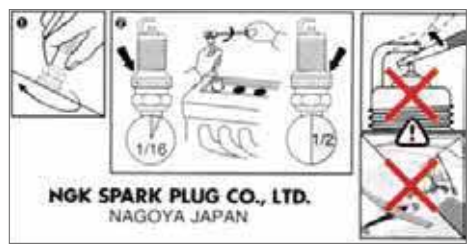



WICHTIGE TIPPS ZUM AUS- UND EINBAU VON GLÜHKERZEN

1 Ausbau / Abreissmomente



Beim Glühkerzenwechsel muss immer ein geeigneter Drehmomentschlüssel verwendet werden, damit das Abreissmoment nicht überschritten wird – ansonsten droht der Abriss.

Glühkerzen Abreißmomente				
Ø Gewinde	M8	M9	M10	M12
Abreißmomente	20Nm	30Nm	40Nm	50Nm

Achtung: Andere Hersteller haben aufgrund unterschiedlicher Gewindematerialien oft geringere Abreißmomente. Daher sollten Sie den Wert um 5 Nm verringern, sofern der Glühkerzenhersteller nicht bekannt ist.

2 Tipps bei Ausbau-Problemen

Ist ein sofortiger Ausbau nicht dringend notwendig, empfehlen wir folgende Vorgehensweise:

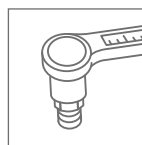
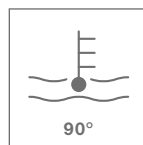

- > Glühkerzensitz am Übergang zum Zylinderkopf mit Synthetikmotoröl beträufeln.
- > Einige Tage einwirken lassen und Fahrzeug bewegen.
- > Glühkerze bei betriebswarmem Motor unter Beachtung der Abreißmomente mittels geeignetem Drehmomentschlüssel ausbauen.

3 Reinigung



Vor dem Einbau neuer Glühkerzen sollten die Ölkohle- und Rußrückstände mit einer eingefetteten Reibahle aus der Glühkerzenbohrung entfernt werden.

4 Einbau / Anzugsdrehmomente Glühkerzen

Gewinde Ø	Metallstabglühkerze					Keramische Glühkerze	
	M8	M9	M10	M12	M14	M8	M10
Anzugsdrehmoment	8,5Nm	11Nm	15Nm	23Nm	23Nm	10Nm	18Nm
Toleranz in %	+/- 10	+/- 10	+/- 10	+/- 10	+/- 10	+/- 10	+/- 10

Anschlussmutter		
Gewinde Ø	M4	M5
Anzugsdrehmoment	0,8–1,5 Nm	3,0–4,0 Nm
Toleranz in %	+/- 10	+/- 10

! Bitte beachten Sie die Anzugsdrehmomente, sofern diese auf der Verpackung angegeben sind! Nur wenn Glühkerzen mit den richtigen Drehmomenten eingeschraubt werden, funktionieren sie einwandfrei!



CONSEILS IMPORTANTS POUR LE MONTAGE DE BOUGIES

Une clé dynamométrique est obligatoire pour monter correctement une bougie d'allumage. Même pour un réparateur confirmé, il est pratiquement impossible d'estimer précisément un couple de serrage. Le couple de serrage est à deux composantes : La force au point de rotation et la longueur du levier. Ce qui rend son estimation

difficile. La majorité des pannes liées aux bougies d'allumage sont dues à un couple de serrage incorrect. S'il est trop faible, la perte de compression peut générer une surchauffe et les vibrations peuvent créer une rupture de l'isolant ou de l'électrode centrale. A contrario, s'il est trop élevé, il peut provoquer un arrachage du filetage de

la bougie d'allumage. Le culot peut également se serrer dans la culasse. Les zones d'évacuation de chaleur peuvent se détruire, ce qui peut provoquer une surchauffe et une fonte des électrodes voire même une panne du moteur.

Couples de serrage des bougies

Le couple de serrage nécessaire dépend du type de siège, du diamètre du filetage et du matériau de culasse. Veuillez respecter les couples ou bien les angles de serrage lorsque ceux-ci sont indiqués sur l'emballage !

1 Type de siège

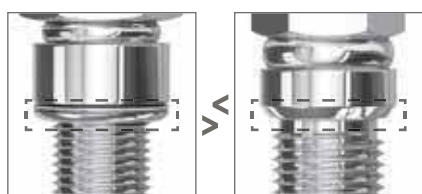

Plat ou conique

2 Diamètre du filetage



3 Matériau de la culasse

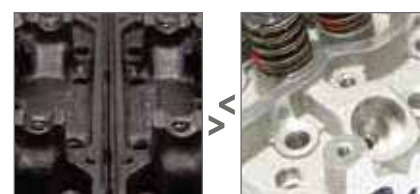

Fonte ou aluminium

1	Type de siège	Bougie avec siège plat (avec joint)				Bougie avec siège conique	
	2 Ø du filetage	10 mm	12 mm	14 mm	18 mm	12/14 mm	18 mm
3	Culasse en fonte	10-15 Nm	15-25 Nm	25-35 Nm	35-45 Nm	15-25 Nm	20-30 Nm
	Culasse en aluminium	10-12 Nm	15-20 Nm	25-30 Nm	35-40 Nm	10-20 Nm	20-30 Nm

Alternative : indications d'angle de rotation (s'applique aux nouvelles bougies)

L'angle de serrage se trouve sur la boîte de la bougie d'allumage (Exception : bougies Racing - méthode du couple uniquement)

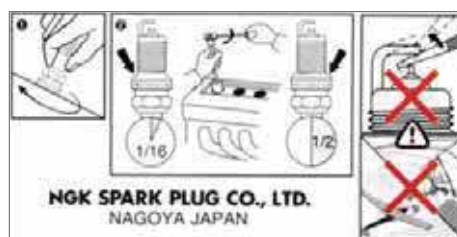



CONSEILS IMPORTANTS POUR LE MONTAGE ET LE DÉMONTAGE DE BOUGIES DE PRÉCHAUFFAGE

1 Démontage



Le démontage des bougies de préchauffage est souvent difficile et entraîne la casse de la bougie. Les couples de cisaillement (voir 2) ne doivent pas être dépassés lors du dévissage.

Couples de cisaillement				
Ø de filetage	M8	M9	M10	M12
Couples de cisaillement	20 Nm	30 Nm	40 Nm	50 Nm

Attention : d'autres fabricants, du fait de matériaux différents des filetages, ont souvent des couples de cisaillement plus faibles. C'est pour cette raison que vous devez réduire la valeur de 5 Nm si vous ne connaissez pas le fabricant de la bougie de préchauffage.

2 Conseils en cas de problème de démontage

Si un démontage immédiat n'est pas urgent, nous vous recommandons de suivre les étapes suivantes :

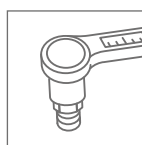
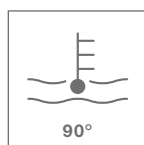

- > Arrosez le puits de la bougie de préchauffage avec de l'huile moteur synthétique.
- > Laissez agir quelques jours et déplacez le véhicule.
- > Démontez la bougie de préchauffage avec le moteur assez chaud pour son fonctionnement, en respectant les couples de cisaillement à l'aide de la clé dynamométrique adaptée.

3 Nettoyage



Avant le montage de nouvelles bougies de préchauffage, il faut que les résidus de calamine et de rouille soient retirés à l'aide d'un alésoir graissé pour les retirer de l'orifice de la bougie de préchauffage.

4 Couples de serrage des bougies de préchauffage

Ø de filetage	Bougies de préchauffage métalliques					céramique	
	M8	M9	M10	M12	M14	M8	M10
Couple de serrage	8,5Nm	11Nm	15Nm	23Nm	23Nm	10Nm	18Nm
Tolérance en %	+/- 10	+/- 10	+/- 10	+/- 10	+/- 10	+/- 10	+/- 10

Écrou de raccordement		
Ø de filetage	M4	M5
Couple de serrage	0,8–1,5Nm	3,0–4,0Nm
Tolérance en %	+/- 10	+/- 10

 Veuillez respecter les couples ou bien les angles de serrage dans la mesure où ceux-ci sont indiqués sur l'emballage ! Les bougies ne fonctionneront sans problème que si elles sont vissées avec le couple de serrage correct !



CONSIGLI IMPORTANTI PER L'INSTALLAZIONE DELLE CANDELE

Per installare a regola d'arte una candela di accensione è necessario utilizzare una chiave dinamometrica. La coppia di serraggio è data dal prodotto tra la forza applicata per il serraggio e la lunghezza del braccio della chiave (leva). Molti degli inconvenienti riscontrabili sulle candele sono riconducibili ad una coppia di

serraggio errata. Se la coppia risulta troppo bassa potrebbe verificarsi una rottura dell'isolatore o dell'elettrodo centrale in conseguenza delle vibrazioni. Se la coppia di serraggio risulta troppo elevata, il corpo metallico della candela potrebbe subire deformazioni a tal punto da compromettere l'efficienza dello scambio termico della candela.

Naturale conseguenza sono fenomeni di surriscaldamento e danni al motore.

Coppie di serraggio delle candele

La coppia di serraggio necessaria dipende dal tipo di sede, dal diametro del filetto e dal materiale della testata. Se le coppie o gli angoli di serraggio sono indicati sulla confezione, atteniti a quanto indicato!

1 Tipo di sede

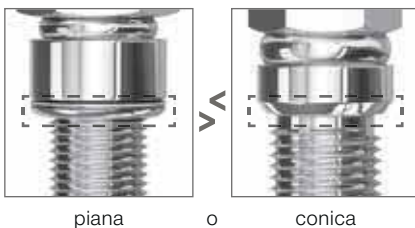

piana o conica

2 ø della filettatura



3 Materiale della testata

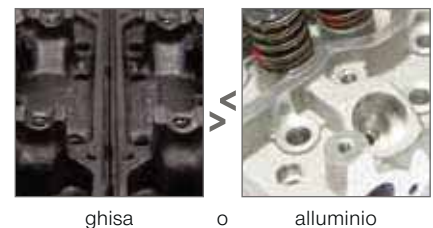

ghisa o alluminio

1	Tipo di sede	Candela a sede piana (con guarnizione)				sede conica	
		10 mm	12 mm	14 mm	18 mm	12/14 mm	18 mm
3	Testata in ghisa	10-15 Nm	15-25 Nm	25-35 Nm	35-45 Nm	15-25 Nm	20-30 Nm
	Testata in alluminio	10-12 Nm	15-20 Nm	25-30 Nm	35-40 Nm	10-20 Nm	20-30 Nm

Alternativa: angolo di serraggio (validi per le candele nuove)

Il rispettivo angolo di rotazione può essere trovato sulla scatola della candela. (Eccezione: candele racing - indicata solo coppia di serraggio)

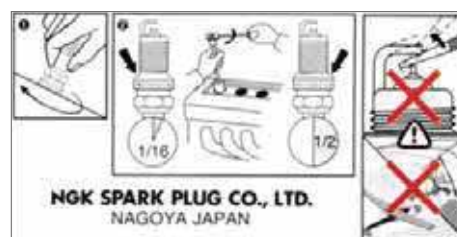



CONSIGLI IMPORTANTI PER LA SOSTITUZIONE DELLE CANDELETTE

1 Smontaggio



Smontare le candele è spesso difficile e comporta il rischio di rottura. Non superare le coppie di rottura (vedere il punto 2) durante lo svitamento.

Coppie di rottura

Ø della filettatura	M8	M9	M10	M12
Coppie di rottura	20 Nm	30 Nm	40 Nm	50 Nm

Attenzione: per via dei diversi materiali del filetto, altri produttori spesso prevedono coppie di rottura inferiori. Se il produttore delle candele non è noto, ridurre il valore di 5 Nm.

2 Consigli in caso di problemi di smontaggio

Se non si ha urgenza di procedere con lo smontaggio, consigliamo di procedere come indicato di seguito:

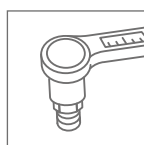
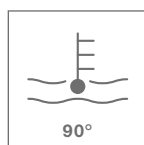

- > Versare dell'olio motore sintetico nel punto di contatto con la testata.
- > Lasciar agire per alcuni giorni utilizzando il veicolo.
- > Servendosi di una chiave dinamometrica adatta, smontare la candele con il motore alla temperatura di esercizio rispettando le coppie di rottura.

3 Pulizia



Prima di montare candele nuove, rimuovere i residui di olio carbonizzato e di fuliggine dal foro delle candele con un alesatore.

4 Coppie di serraggio delle candele

Ø della filettatura	Candele metallica					Candele ceramica	
	M8	M9	M10	M12	M14	M8	M10
Coppia di serraggio	8,5Nm	11Nm	15Nm	23Nm	23Nm	10Nm	18Nm
Tolleranza in %	+/- 10	+/- 10	+/- 10	+/- 10	+/- 10	+/- 10	+/- 10

Ø della filettatura	Dado del terminale	
	M4	M5
Coppia di serraggio	0,8-1,5 Nm	3,0-4,0 Nm
Tolleranza in %	+/- 10	+/- 10



Se le coppie di serraggio sono indicate sulla confezione, atteniti a quanto indicato! Le candele funzionano perfettamente soltanto se sono installate con le coppie di serraggio corrette!



RECOMENDACIONES IMPORTANTES PARA EL MONTAJE DE LAS BUJÍAS

Pares de apriete para montar correctamente una bujía se necesita una llave dinamométrica, puesto que incluso para los técnicos profesionales de los talleres resulta casi imposible calcular el par de apriete correcto. Esto se debe a que los pares de apriete se calculan multiplicando dos dimensiones: la fuerza que se aplica sobre el punto de giro

correspondiente y la longitud de la palanca. La mayoría de los fallos que se producen en las bujías se deben a que el par de apriete es incorrecto. Si es demasiado bajo, las pérdidas de compresión podrían provocar un sobrecalentamiento. También se podría romper el aislador o el electrodo central a consecuencia de las vibraciones. Si el

par de apriete es demasiado alto, la bujía se podría romper. También la caja podría expandirse o torcerse. Las zonas de salida del calor se estropearían, los electrodos podrían sufrir sobrecalentamiento o fundirse y provocar una avería en el motor.

Pares de apriete de las bujías

El par de apriete necesario depende del tipo de asiento, el diámetro de la rosca y el material de la culata. Observe el par o el ángulo de apriete cuando estos se indiquen en el embalaje.

1 Tipo de asiento

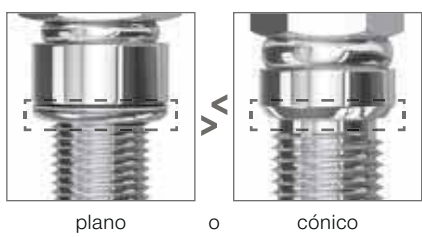

2 Diámetro de la rosca



3 Material de la culata

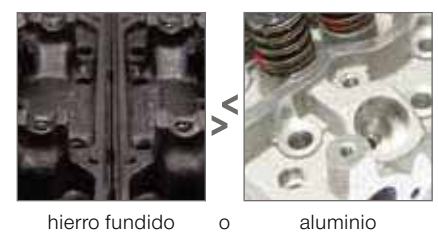

1	Tipo de asiento	Bujía con asiento plano (con junta)				Bujía con asiento cónico	
2	Ø de la rosca	10 mm	12 mm	14 mm	18 mm	12/14 mm	18 mm
3	Culata de hierro fundido	10-15 Nm	15-25 Nm	25-35 Nm	35-45 Nm	15-25 Nm	20-30 Nm
	Culata de aluminio	10-12 Nm	15-20 Nm	25-30 Nm	35-40 Nm	10-20 Nm	20-30 Nm

Alternativa: Datos del ángulo de apriete

El ángulo de rotación respectivo se puede encontrar en el embalaje de la bujía. (Excepción: pipas de competición: solo método de torsión)

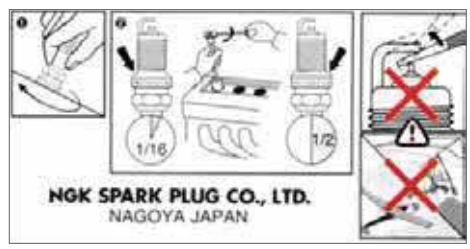



RECOMENDACIONES IMPORTANTES PARA EL DESMONTAJE Y EL MONTAJE DE LOS CALENTADORES

1 Pares de desmontaje/rotura



Para cambiar los calentadores se debe utilizar siempre una llave dinamo-métrica adecuada para no superar el par de rotura, porque de lo contrario existe el riesgo de que se rompan.

Pares de rotura de los calentadores

Ø de la rosca	M8	M9	M10	M12
Par de rotura	20 Nm	30 Nm	40 Nm	50 Nm

Advertencia: es frecuente que los pares de apriete de otros fabricantes sean menores porque utilizan otros materiales para la rosca. Por lo tanto, el valor debe reducirse 5 Nm si no se conoce el fabricante del calentador.

2 Recomendaciones para los problemas de desmontaje

Si no es necesario realizar el desmontaje de forma inmediata, le recomendamos lo siguiente:

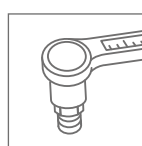
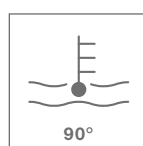

- > Impregnar con aceite de motor sintético el área de transición entre el asiento del calentador y la culata.
- > Dejarlo actuar unos días y mover el vehículo.
- > Desmontar el calentador con el motor a temperatura de funcionamiento y observando los pares de rotura con una llave dinamo-métrica adecuada.

3 Limpieza



Antes de montar calentadores nuevos se deben retirar los restos de carbonilla y hollín con un escariador engrasado del orificio del calentador.

4 Montaje/pares de apriete de los calentadores

Ø de la rosca	Calentadores metálicos					Calentadores cerámicos	
	M8	M9	M10	M12	M14	M8	M10
Par de apriete	8,5Nm	11Nm	15Nm	23Nm	23Nm	10Nm	18Nm
Tolerancia en %	+/- 10	+/- 10	+/- 10	+/- 10	+/- 10	+/- 10	+/- 10

Ø de la rosca	Tuerca de unión	
	M4	M5
Par de apriete	0,8-1,5Nm	3,0-4,0Nm
Tolerancia en %	+/- 10	+/- 10

 Observe el par de apriete cuando este se indique en el embalaje. Los calentadores solo funcionan correctamente cuando se enroscan con el par de apriete correcto.



BELANGRIJKE TIPS VOOR DE INBOUW VAN BOUGIES

Voor de vakkundige montage van een bougie is een draaimomentsleutel noodzakelijk. Want zelfs voor vakmensen uit een garage is het vrijwel onmogelijk om het aandraaimoment te schatten. Dat komt doordat een aandraaimoment berekend wordt door twee grootheden met elkaar te vermenigvuldigen: de kracht, die op het betreffende draaipunt

inwerkt en de lengte van de hendel. Als een bougie uitvalt, is een verkeerd aandraaimoment meestal de oorzaak hiervan. Als het aandraaimoment te laag is, bestaat gevaar voor compressieverlies en oververhitting. Ook is een breuk van de isolator of de middenelektrode denkbaar als gevolg van trillingen. Als het aandraaimoment

te hoog is, kan de bougie afbreken. Ook kan de behuizing uitzetten of zich verdraaien. De zones voor de warmteafleiding worden vernield, er bestaat gevaar voor oververhitting, samensmelten van de elektroden en zelfs motorschade.

Aandraaimomenten bougies

Het vereiste aandraaimoment is afhankelijk van de zitting, het schroefdraad diameter en het materiaal van de cilinderkop. Houd rekening met de aandraaimomenten of -hoeken als deze op de verpakking staan aangeduid!

1 Zitting

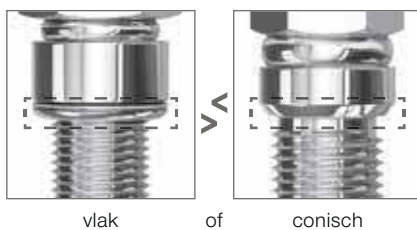

vlak of conisch

2 Schroefdraad diameter



3 Materiaal cilinderkop

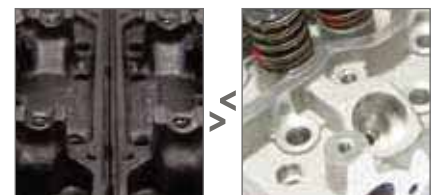

gietijzer of aluminium

1 Zitting	Bougie met vlakke zitting (met pakking)				Bougie met conische zitting		
	10 mm	12 mm	14 mm	18 mm	12/14 mm	18 mm	
2 Schroefdraad Ø							
3	gietijzeren kop	10-15 Nm	15-25 Nm	25-35 Nm	35-45 Nm	15-25 Nm	20-30 Nm
	aluminium kop	10-12 Nm	15-20 Nm	25-30 Nm	35-40 Nm	10-20 Nm	20-30 Nm

Alternatief: Specificaties voor verdraaiingshoek

De betreffende aanhaalhoek staat op de bougieverpakking. (Uitzondering: race bougies - alleen aanhaalmoment)

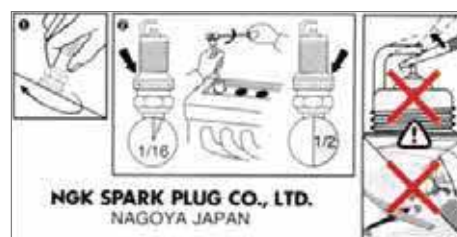



BELANGRIJKE TIPS VOOR INBOUWEN EN VERWIJDEREN VAN GLOEIBOUGIES

1 Demontage- / afbrekmomenten



Tijdens de vervanging van gloeibougies moet altijd een geschikte momentsleutel worden gebruikt, zodat het afbrekmoment niet wordt overschreden – met een mogelijke breuk als gevolg.

Gloeibougies afbrekmomenten				
Ø schroefdraad	M8	M9	M10	M12
Afbrekmoment	20 Nm	30 Nm	40 Nm	50 Nm

Let op: Andere fabrikanten hebben op basis van uiteenlopend schroefdraadmateriaal vaak lagere afbrekmomenten. Daarom adviseren wij u een waarde van 5 Nm minder te nemen, als de fabrikant van de gloeibougie onbekend is.

2 Tips voor als er problemen bij de verwijdering zijn

Als een onmiddellijke demontage niet dringend noodzakelijk is, raden wij de volgende aanpak aan:

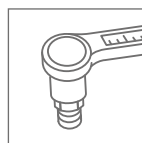
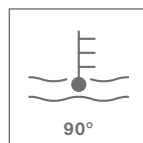

- > De zitting van de gloeibougie bij de overgang naar de cilinderkop met synthetische motorolie bedruppelen.
- > Enkele dagen laten inwerken en het voertuig gebruiken.
- > Gloeibougie bij warme motor met een geschikte momentsleutel demonteren, rekening houdend met het afbrekmoment.

3 Reiniging



Voor de montage van nieuwe gloeibougies moeten de kool- en roetresten met een ingevette ruimer uit de gloeibougie-kanalen worden verwijderd.

4 Inbouw / aanhaalmoment gloeibougies

Ø schroefdraad	Metalen bougies					Keramische gloeibougies	
	M8	M9	M10	M12	M14	M8	M10
Aanhaalmoment	8,5Nm	11Nm	15Nm	23Nm	23Nm	10Nm	18Nm
Tolerantie in %	+/- 10	+/- 10	+/- 10	+/- 10	+/- 10	+/- 10	+/- 10

Vleugelmoer		
Ø schroefdraad	M4	M5
Aanhaalmoment	0,8–1,5 Nm	3,0–4,0 Nm
Tolerantie in %	+/- 10	+/- 10

 Houd rekening met de aandraaimomenten voor zover deze op de verpakking staan aangeduid! Alleen wanneer gloeibougies met de juiste draaimomenten worden gemonteerd, functioneren ze probleemloos!



DICAS IMPORTANTES PARA A MONTAGEM DE VELAS DE IGNIÇÃO

O torque de aperto correcto para velas de ignição para a montagem correcta de uma vela de ignição é necessário usar uma chave dinamométrica. Porque mesmo o mecânico mais experiente é incapaz de “estimar” o torque de aperto. Isto se explica pelo fato do binário para ser calculado a partir de dois valores que são multiplicados: A força,

que actua no respectivo ponto rotativo, e o comprimento da alavanca. A maior parte das falhas das velas de ignição resultam de um torque de aperto errado. Se este for demasiado baixo, existe o risco de perdas de compressão e de sobreaquecimento. Também é possível que aconteça uma quebra do isolador ou do eléctrodo central por

causa das vibrações. Por outro lado, ao escolher um binário demasiado alto, isto pode levar à ruptura da vela de ignição. A carcaça além disso pode ficar dilatada ou distorcida. As zonas de dissipação de calor ficam danificadas, existe o risco de fundição dos eléctrodos e, inclusive, de gripar o motor.

Torques de aperto das velas de ignição

O torque de aperto necessário depende do tipo de assento, do diâmetro da rosca e do material do cabeçote do cilindro. Por favor observe os torques ou ângulos de aperto, caso os mesmos sejam indicados na embalagem!

1 Tipo de assento

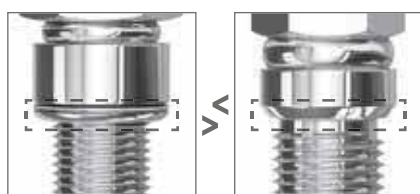

plano ou cônico

2 Diâmetro da rosca



3 Material do cabeçote do cilindro



ferro fundido ou alumínio

1	Tipo de assento	Vela de ignição com assento plano (com gaxeta)				Vela de ignição com assento cônico	
		10 mm	12 mm	14 mm	18 mm	12/14 mm	18 mm
3	Cabeçote de ferro fundido	10-15 Nm	15-25 Nm	25-35 Nm	35-45 Nm	15-25 Nm	20-30 Nm
	Cabeçote de alumínio	10-12 Nm	15-20 Nm	25-30 Nm	35-40 Nm	10-20 Nm	20-30 Nm

Alternativa: Dados sobre o ângulo de rotação

O respectivo ângulo de rotação pode ser encontrado na embalagem da vela de ignição (exceção: cachimbo de competição: só método de torque)

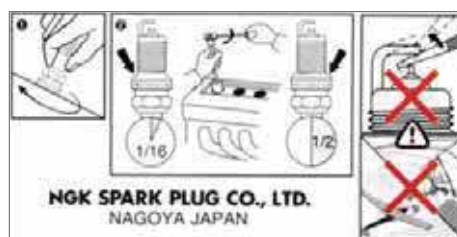



DICAS IMPORTANTES PARA A DESMONTAGEM E MONTAGEM DE VELAS AQUECEDORAS

1 Desmontagem / momentos de ruptura



Quando é feita a troca das velas aquecedoras é necessário usar sempre uma chave dinamométrica apropriada para evitar que o momento de ruptura seja ultrapassado, caso contrário, existe o perigo de uma ruptura.

Momentos de ruptura das velas aquecedoras

Ø rosca	M8	M9	M10	M12
Momento de ruptura	20Nm	30Nm	40Nm	50Nm

Atenção: Os outros fabricantes têm frequentemente momentos de ruptura mais reduzidos devido a materiais de rosca diferentes. Por essa razão, você deve reduzir o valor em 5 Nm, se o fabricante da vela aquecedora não for conhecido.

2 Dicas em caso de problemas na desmontagem

Se não for necessário efetuar a desmontagem imediata, recomendamos o seguinte procedimento:

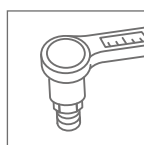
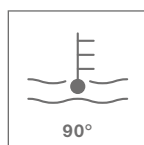

- > Salpicar o assento da vela aquecedora na passagem para o cabeçote do cilindro com óleo sintético para motores.
- > Deixar atuar durante alguns dias e movimentar o veículo.
- > Desmontar a vela aquecedora com motor quente, mediante uma chave dinamométrica apropriada, observando os momentos de ruptura.

3 Limpeza



Antes de serem montadas novas velas aquecedoras, é necessário remover os resíduos de carvão de óleo e fuligem do furo das velas aquecedoras, mediante um alargador.

4 Montagem / torques de aperto das velas aquecedoras

Vela aquecedora de haste metálica						Vela aquecedora cerâmica	
Ø rosca	M8	M9	M10	M12	M14	M8	M10
Torque de aperto	8,5Nm	11Nm	15Nm	23Nm	23Nm	10Nm	18Nm
Tolerância em %	+/- 10	+/- 10	+/- 10	+/- 10	+/- 10	+/- 10	+/- 10

Porca de conexão		
Ø rosca	M4	M5
Torque de aperto	0,8–1,5Nm	3,0–4,0Nm
Tolerância em %	+/- 10	+/- 10

 Por favor observe os torques de aperto, caso os mesmos sejam indicados na embalagem! As velas aquecedoras só funcionam perfeitamente, se as mesmas forem aparafusadas com o torque de aperto correto!



ΧΡΗΣΙΜΕΣ ΣΥΜΒΟΥΛΕΣ ΓΙΑ ΤΗΝ ΤΟΠΟΘΕΤΗΣΗ ΤΩΝ ΜΠΟΥΖΙ

Για την τοποθέτηση ενός μπουζί σύμφωνα με τους κανόνες, απαιτείται η χρήση ενός ροπόκλειδου. Ακόμη και για τους επαγγελματίες των συνεργείων η „εκτίμηση“ της ορθής ροπής σύσφιξης είναι σχεδόν αδύνατη. Αυτό έγκειται στο ότι η ροπή σύσφιξης υπολογίζεται από δύο μεγέθη, τα οποία πολλαπλασιάζονται μεταξύ τους: από τη δύναμη, η οποία

επενεργεί στο αντίστοιχο σημείο περιστροφής και το μήκος του μοχλού. Οι περισσότερες δυσλειτουργίες των μπουζί οφείλονται στη λανθασμένη ροπή σύσφιξης. Εάν επιλεγεί πολύ μικρή, υπάρχει ο κίνδυνος απώλειας συμπίεσης και υπερθέρμανσης. Είναι πιθανή, ακόμη και η ρήξη του μονωτήρα ή του κεντρικού ηλεκτροδίου, λόγω των κραδασμών.

Εφόσον η ροπή σύσφιξης είναι πολύ ψηλή, μπορεί να προκληθεί αποκοπή του μπουζί. Ακόμη ενδέχεται να διασταλεί το περίβλημα ή να συστραφεί. Οι ζώνες απαγωγής θερμότητας διαταράσσονται, παρουσιάζεται η απειλή υπερθέρμανσης και τήξης των ηλεκτροδίων, μέχρι και η πρόκληση ζημιάς στον κινητήρα.

Ροπή σύσφιξης μπουζί

Η απαιτούμενη ροπή σύσφιξης καθορίζεται από τον τύπο έδρας του μπουζί, τη διάμετρο του σπειρώματος και το υλικό της κυλινδροκεφαλής. Εάν στη συσκευασία αναγράφεται η ροπή ή η γωνία σύσφιξης, ακολουθήστε τις οδηγίες!

1 Τύπος έδρας

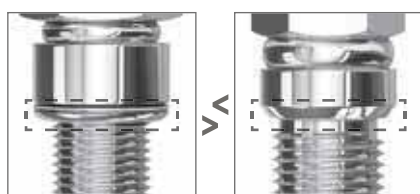

επίπεδη ή κωνική

2 Διάμετρος σπειρώματος



3 Υλικό κυλινδροκεφαλής

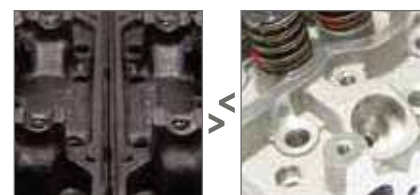

χυτοσίδηρος ή αλουμίνιο

1	Τύπος έδρας	Μπουζί με επίπεδη έδρα (με ροδέλα)				Μπουζί με κωνική έδρα	
2	Σπειρώμα Ø	10 mm	12 mm	14 mm	18 mm	12/14 mm	18 mm
3	κυλινδροκεφαλή από χυτοσίδηρο	10-15 Nm	15-25 Nm	25-35 Nm	35-45 Nm	15-25 Nm	20-30 Nm
	κυλινδροκεφαλή από αλουμίνιο	10-12 Nm	15-20 Nm	25-30 Nm	35-40 Nm	10-20 Nm	20-30 Nm

Εναλλακτικά: Γωνία σύσφιξης-στοιχεία

Η αντίστοιχη γωνία περιστροφής μπορεί να βρεθεί στη συσκευασία μπουζί. (Εξαιρέση: αγώνιστικά μπουζί - ροπόκλειδο μόνο)

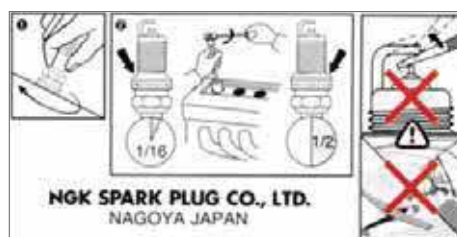



ΧΡΗΣΙΜΕΣ ΣΥΜΒΟΥΛΕΣ ΓΙΑ ΤΗΝ ΑΦΑΙΡΕΣΗ ΚΑΙ ΤΗΝ ΤΟΠΟΘΕΤΗΣΗ ΤΩΝ ΠΡΟΘΕΡΜΑΝΤΗΡΩΝ

1 Αφαίρεση / Ροπή θραύσης



Κατά την αλλαγή των προθερμαντήρων είναι απαραίτητη η χρήση του κατάλληλου ροπόκλειδου για την αποφυγή της θραύσης τους.

Προθερμαντήρες - Ροπή θραύσης				
Ø Σπείρωμα	M8	M9	M10	M12
Ροπή σύσφιξης	20 Nm	30 Nm	40 Nm	50 Nm

Προσοχή: Άλλοι κατασκευαστές διαθέτουν μικρότερες ροπές θραύσης λόγω των διαφορετικών υλικών των σπειρωμάτων. Σε περίπτωση που ο κατασκευαστής δεν είναι γνωστός, μειώστε τη ροπή σύσφιξης κατά 5 Nm.

2 Συμβουλές για την αποφυγή προβλημάτων κατά την αφαίρεση

Εάν δεν απαιτείται άμεση αφαίρεση, συνιστάται η ακόλουθη διαδικασία:

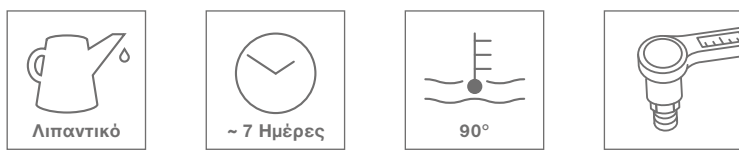

- > Λίπανση με συνθετικό λιπαντικό στο σημείο μεταξύ της βάσεως του προθερμαντήρα και της κυλινδροκεφαλής.
- > Αφήστε να δράσει μερικές μέρες κυκλοφορώντας το αυτοκίνητο.
- > Αφαιρέστε τον προθερμαντήρα με κατάλληλο ροπόκλειδο και την κατάλληλη ροπή εφόσον ο κινητήρας έχει προθερμανθεί.

3 Καθαρισμός



Πριν την τοποθέτηση νέων προθερμαντήρων αφαιρέστε με τη βοήθεια ενός ειδικού αλεξουάρ τα υπολείμματα λιπαντικού και αιθάλης από την οπή του προθερμαντήρα.

4 Τοποθέτηση / Ροπή σύσφιξης προθερμαντήρων

Μεταλλικοί προθερμαντήρες						Κεραμικοί προθερμαντήρες	
Σπείρωμα Ø	M8	M9	M10	M12	M14	M8	M10
Ροπή σύσφιξης	8,5Nm	11Nm	15Nm	23Nm	23Nm	10Nm	18Nm
Ανοχή %	+/- 10	+/- 10	+/- 10	+/- 10	+/- 10	+/- 10	+/- 10

παξιμάδι ακροδέκτη		
Σπείρωμα Ø	M4	M5
Ροπή σύσφιξης	0,8–1,5 Nm	3,0–4,0 Nm
Ανοχή %	+/- 10	+/- 10

! Εάν στη συσκευασία αναγράφεται η ροπή σύσφιξης, ακολουθήστε τις οδηγίες! Μόνο εφόσον χρησιμοποιηθεί η σωστή ροπή σύσφιξης, οι προθερμαντήρες λειτουργούν άψογα!



ATEŞLEME BUJİLERİNİN KURULUMU İÇİN ÖNEMLİ İPUÇLARI

Bir bujinin usule uygun montajı için ayarlı tork anahtarı gereklidir. Çünkü usta oto servisçiler için bile sıkma torkunu tahmin etmek neredeyse imkansızdır. Bunun nedeni, sıkma torkunun birbiriyle çarpılan iki parametreden hesaplanmasıdır: ilgili döndürme noktasına etki eden kuvvet ve manivela kolunun uzunluğu. Buji

arızalarının çoğu yanlış sıkma torkundan kaynaklanır. Sıkma torku fazla küçük seçilirse sıkışma kayıpları ve aşırı hararet tehlikesi vardır. Ayrıca titreşimler sonucunda izolatörün ya da orta elektrodun kırılması da akla gelebilecek ihtimallerdir. Sıkma torku fazla büyük seçilirse, bu durum bujinin kopmasına yol açabilir. Ayrıca gövde genleşebilir

ya da burulabilir. Isı iletim bölgeleri zedelenir, aşırı hararet ve elektrotların erimesi ve hatta motorun hasar görmesi tehlikesi vardır.

Kızdırma bujisi sıkma torqları

Gerekten sıkma torku; oturma türüne, dış çapına ve silindir başlığının malzemesine bağlıdır. Ambalajın üzerinde yazıyorsa lütfen sıkma torqlarına veya açılara dikkat edin!

1 Oturma Tipi

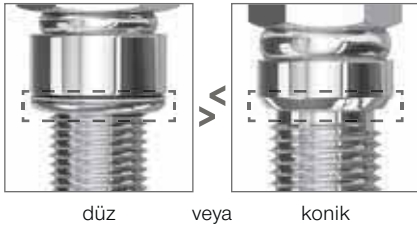

düz veya konik

2 Dış çapı



3 Silindir başlığı malzemesi

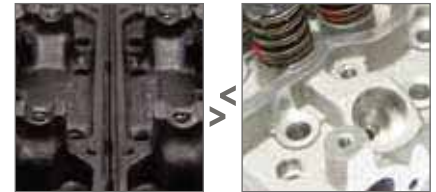

Dökme demir veya Alüminyum

1	Oturma tipi	Düz yataklı ateşleme bujisi (contalı)				Konik yataklı ateşleme bujisi	
		10 mm	12 mm	14 mm	18 mm	12/14 mm	18 mm
3	Dökme demir başlığı	10-15 Nm	15-25 Nm	25-35 Nm	35-45 Nm	15-25 Nm	20-30 Nm
	Alüminyum başlık	10-12 Nm	15-20 Nm	25-30 Nm	35-40 Nm	10-20 Nm	20-30 Nm

Alternatif: Dönüş açısı ayrıntıları

İlgili dönme açısı buji ambalajı üzerinde bulunmaktadır. (İstisna: yarış bujileri - sadece tork yöntemi)

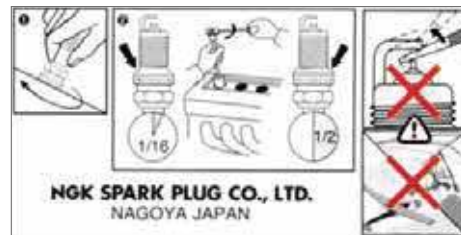



KIZDIRMA BUJİLERİNİN SÖKMEK VE TAKMAK İÇİN ÖNEMLİ İPUÇLARI

1 Sökme / Kopma Torku



Kızdırma bujilerini değiştirirken kopma torku aşılmayacak biçimde daima doğru torku kullanmanız gerekir. Aksi takdirde parçanın kopup fırlama tehlikesi vardır.

Kızdırma bujisi kopma torku

Dis Ø	M8	M9	M10	M12
Kopma torku	20 Nm	30 Nm	40 Nm	50 Nm

Not: Diğer üreticilerin değişen diş malzemelerinden dolayı daha düşük kopma torkları vardır. Bu nedenle, kızdırma bujisi üreticisi bilinmiyorsa değeri 5 Nm daha düşürmeniz gerekir.

2 Sökme sorunlarıyla ilgili ipuçları

Hemen sökme aciliyetiniz yoksa, şu şekilde devam etmenizi öneririz:

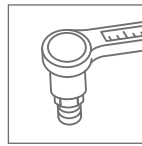
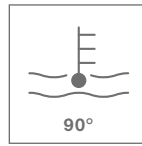

- > Kızdırma bujisi yatağının silindir başlığına geçtiği yere sentetik motor yağı püskürtün.
- > Birkaç gün bu yağı emmesini bekleyin ve aracı sürün.
- > Kızdırma bujilerini motorun çalışma sıcaklığında uygun bir tork anahtarı kullanarak sökün. Kopma torkuna dikkat edin.

3 Temizleme



Yeni kızdırma bujilerini takmadan önce yağ ve kurum atıkları yağlı bir rayba kullanılarak kızdırma bujisi deliğinden temizlenmelidir.

4 Kızdırma bujisini takma / sıkma torkları

Metal çubuklu kızdırma bujileri						Seramik kızdırma bujileri	
Dis Ø	M8	M9	M10	M12	M14	M8	M10
Sıkma torku	8,5Nm	11Nm	15Nm	23Nm	23Nm	10Nm	18Nm
% olarak tolerans	+/- 10	+/- 10	+/- 10	+/- 10	+/- 10	+/- 10	+/- 10

Bağlantı somunu		
Dis Ø	M4	M5
Sıkma torku	0,8–1,5Nm	3,0–4,0Nm
% olarak tolerans	+/- 10	+/- 10



Ambalajın üzerinde yazıyorsa lütfen sıkma torklarına dikkat edin! Kızdırma bujileri yalnızca sıkma torkları doğru olduğunda düzgün çalışır!



WAŻNE WSKAZÓWKI DOTYCZĄCE MONTAŻU ŚWIEC ZAPŁONOWYCH

Momenty dokręcenia: Do fachowego montażu świecy zapłonowej konieczny jest klucz dynamometryczny, ponieważ nawet sami mechanicy nie są w stanie dokładnie określić momentu dokręcenia. Wynika to z tego, że moment dokręcenia oblicza się mnożąc przez siebie dwie wielkości: siłę, która działa w danym punkcie obrotu

oraz długość dźwigni. Większość uszkodzeń świec zapłonowych spowodowanych jest błędnym momentem dokręcenia. Jeśli wybierze się zbyt mały moment dokręcenia, może nastąpić utrata sprężenia i przegrzanie. Możliwe jest również pęknięcie izolatora lub elektrody środkowej na skutek drgań. Jeśli

moment dokręcenia będzie za duży, może dojść do zerwania świecy zapłonowej. Także korpus nie będzie mógł się rozciągnąć ani przekręcić. Strefy odpływu ciepła będą zakłócone, a wtedy istnieje niebezpieczeństwo przegrzania i stopienia elektrod aż do uszkodzenia silnika.

Momenty dokręcenia świec zapłonowych

Wymagany moment dokręcenia zależy od typu gniazda, średnicy gwintu oraz materiału głowicy cylindrowej. Należy przestrzegać momentów lub kątów dokręcenia, jeśli są one podane na opakowaniu!

1 Typ gniazda

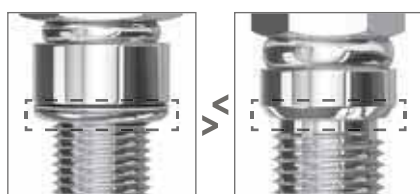

płaskie lub stożkowe

2 Średnica gwintu



3 Materiał głowicy cylindrowej

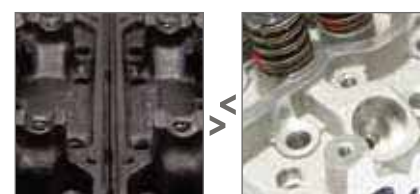

żeliwo lub aluminium

1	Typ gniazda	Świeca zapłonowa z płaskim gniazdem (z uszczelką)				Świeca zapłonowa ze stożkowym gniazdem	
	Średnica gwintu	10 mm	12 mm	14 mm	18 mm	12/14 mm	18 mm
3	głowica żeliwna	10-15 Nm	15-25 Nm	25-35 Nm	35-45 Nm	15-25 Nm	20-30 Nm
	głowica aluminiowa	10-12 Nm	15-20 Nm	25-30 Nm	35-40 Nm	10-20 Nm	20-30 Nm

Alternatywnie: Dane dotyczące momentu dokręcenia

Odpowiedni kąt dokręcenia podany jest na opakowaniu świecy zapłonowej (wyjątek: świece sportowe - tylko momenty dokręcenia)

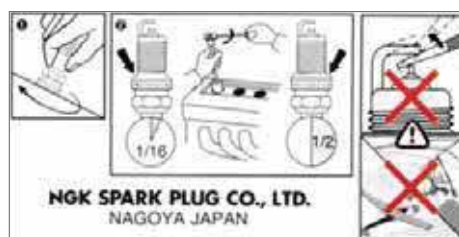



WAŻNE WSKAZÓWKI DOTYCZĄCE DEMONTAŻU I MONTAŻU ŚWIEC ŻAROWYCH

1 Demontaż / momenty zerwania



Podczas wymiany świec żarowych zawsze należy stosować odpowiedni klucz dynamometryczny, aby uniknąć przekroczenia momentu dokręcenia – w przeciwnym razie może dojść do zerwania świecy.

Momenty dokręcenia świec żarowych

Średnica gwintu	M8	M9	M10	M12
Moment dokręcenia	20 Nm	30 Nm	40 Nm	50 Nm

Uwaga: Ze względu na użycie różnych materiałów gwintu, wielu producentów często wyznacza niższe momenty dokręcenia. Jeśli producent świec żarowych nie jest znany, należy zastosować wartość niższą o 5 Nm.

2 Wskazówki zapobiegające problemom z demontażem

Jeśli natychmiastowy demontaż nie jest pilnie wymagany, zalecamy następujący sposób postępowania:

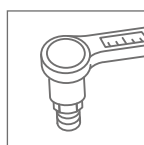
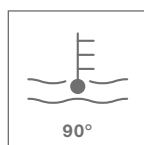

- > Gniazdo świecy żarowej w miejscu przejścia do głowicy cylindrowej posmarować syntetycznym olejem silnikowym.
- > Odczekać kilka dni i przejechać się samochodem.
- > Świecę żarową zdemontować przy pomocy odpowiedniego klucza dynamometrycznego wtedy, gdy silnik jest rozgrzany, z uwzględnieniem momentów dokręcenia.

3 Czyszczenie



Przed montażem nowych świec żarowych należy usunąć z otworów na świece żarowe pozostałości nagaru olejowego i sadzy przy pomocy naoliwionego rozwiertaka.

4 Montaż / momenty dokręcenia świec żarowych

Świece żarowe z metalowym prętym					Ceramiczne świece żarowe		
Średnica gwintu	M8	M9	M10	M12	M14	M8	M10
Moment dokręcenia	8,5Nm	11Nm	15Nm	23Nm	23Nm	10Nm	18Nm
Tolerancja w %	+/- 10	+/- 10	+/- 10	+/- 10	+/- 10	+/- 10	+/- 10

Nakrętka złączowa		
Średnica gwintu	M4	M5
Moment dokręcenia	0,8–1,5 Nm	3,0–4,0 Nm
Tolerancja w %	+/- 10	+/- 10



Należy przestrzegać momentów dokręcenia, jeśli są one podane na opakowaniu! Świece żarowe działają prawidłowo tylko wtedy, gdy są wkręcone z uwzględnieniem odpowiednich momentów dokręcenia!



DŮLEŽITÉ TIPY PRO INSTALACI ZAPALOVACÍCH SVÍČEK

Pro správnou montáž zapalovací svíčky je potřebný momentový klíč. Dokonce i pro profesionála ze servisu je totiž téměř nemožný „odhad“ utahovacího momentu. To je dáno tím, že utahovací moment se vypočítá ze dvou veličin, které se vzájemně násobí: síly, která v daném bodu otáčení působí, a délky páky. Většina výpadků zapalovacích svíček má

příčinu ve špatném utahovacím momentu. Pokud je příliš malý, hrozí ztráty komprese a přehřátí. V důsledku vibrací může dojít i k prasknutí izolátoru nebo střední elektrody. Pokud je utahovací moment příliš velký, může dojít k vytržení zapalovací svíčky. Také může dojít k protažení nebo deformaci korpusu. Dochází k přerušování zón odvodu tepla,

hrozí přehřátí a roztavení elektrod ba dokonce i poškození motoru.

Utahovací momenty zapalovacích svíček

Požadovaný utahovací moment závisí na typu sedla, průměru závitu a materiálu hlavy válce.

Vždy dodržujte utahovací momenty nebo úhly, pokud jsou vytištěné na obalu!

1 Typ sedla

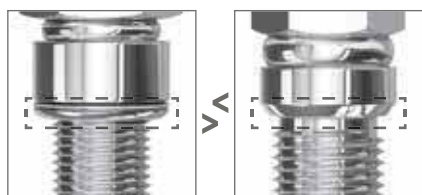

plochý nebo kuželový

2 Průměr závitu



3 Materiál hlavy válce

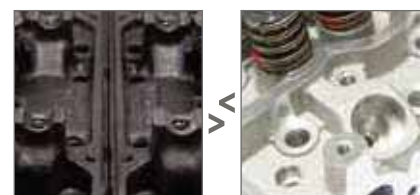

Litina nebo hliník

1	Typ sedla	Zapalovací svíčka s plochým sedlem (s těsněním)				Zapalovací svíčka s kuželovým sedlem	
		10 mm	12 mm	14 mm	18 mm	12/14 mm	18 mm
3	Litinová hlava	10-15 Nm	15-25 Nm	25-35 Nm	35-45 Nm	15-25 Nm	20-30 Nm
	Hliníková hlava	10-12 Nm	15-20 Nm	25-30 Nm	35-40 Nm	10-20 Nm	20-30 Nm

Jiné řešení: Podrobnosti ohledně úhlu otáčení

Příslušný úhel otáčení najdete na obalu zapalovací svíčky.

(Výjimka: závodní zapalovací svíčky – pouze metoda utahovacího momentu)

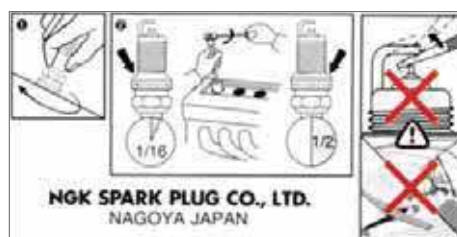



DŮLEŽITÉ TIPY PRO VYJMUTÍ A INSTALACI ŽHAVICÍCH SVÍČEK

1 Vyjmutí / Záběrný moment



Při výměně žhavicích svíček musíte vždy použít správný moment, abyste nepřekročili záběrný moment a nebezpečí utržení.

Záběrný moment u žhavicí svíčky

Ø závitu	M8	M9	M10	M12
Záběrný moment	20 Nm	30 Nm	40 Nm	50 Nm

Poznámka: Jiní výrobci mají kvůli různým materiálům závitu často nižší hodnoty záběrného momentu. Z toho důvodu byste měli snížit jeho hodnotu o 5 Nm, kdykoli neznáte výrobce žhavicích svíček.

2 Tipy pro problémy s vyjímáním svíček

Není-li nutno svíčku okamžitě odstranit, doporučujeme postupovat následovně:

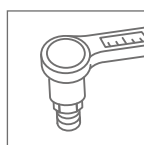
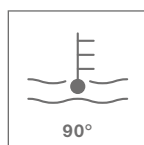

- > Nastříkejte syntetický motorový olej na sedlo žhavicí svíčky v místě přechodu do hlavy válce.
- > Nechte absorbovat několik dní a vozem pohybujte.
- > Vyjměte žhavicí svíčky za provozní teploty motoru a věnujte pozornost záběrnému momentu za použití vhodného momentového klíče.

3 Čištění



Před instalací nových žhavicích svíček odstraňte z otvoru žhavicí svíčky zbytky oleje a sazí pomocí promazaného výstružníku.

4 Instalace / utahovací momenty žhavicích svíček

Žhavicí svíčky s kovovou elektrodou					Keramické žhavicí svíčky		
Ø závitu	M8	M9	M10	M12	M14	M8	M10
Utahovací moment	8,5Nm	11Nm	15Nm	23Nm	23Nm	10Nm	18Nm
Tolerance v %	+/- 10	+/- 10	+/- 10	+/- 10	+/- 10	+/- 10	+/- 10

Spojovací matice		
Ø závitu	M4	M5
Utahovací moment	0,8–1,5 Nm	3,0–4,0 Nm
Tolerance v %	+/- 10	+/- 10



Vždy dodržujte utahovací momenty nebo úhly, pokud jsou vytištěné na obalu! Žhavicí svíčky budou fungovat správně, pouze pokud jsou utaženy správným utahovacím momentem!



FONTOS BESZERELÉSI TANÁCSOK GYÚJTÓGYERTYÁK

A gyújtógyertya szakszerű beszereléséhez ajánlott a nyomatékkulcs használata. A meghúzási nyomaték megbecsülése még a profi szerelők számára is közel lehetetlen. Ez abból adódik, hogy a nyomaték két mennyiség szorzataként adódik: a mindenkori forgásponton

ható erő és az erőkar hossza. A legtöbb gyújtógyertya meghibásodást a hibás meghúzási nyomaték okozza. Ha túl alacsony, kompresszió veszteség és túlhevülés léphet fel. Előfordulhat a szigetelő vagy a középelektroda rezgés okozta törése is. Ha túl magas, a gyertya

elszakadhat. A ház is megnyúlhat ill. elcsavarodhat. Zavar keletkezik a hőelvezetés útjaiban, túlmelegedés és az elektrodák leolvadása fenyeget, ami motorhibát okozhat.

A gyújtógyertya meghúzási nyomatéka

A szükséges meghúzási nyomaték az ülék típusától, a menet átmérőjétől és a hengerfej anyagától függ. Kérjük ügyeljen a meghúzási nyomatékokra, illetve szögekre, amennyiben ezek a csomagoláson feltüntetésre kerültek!

1 A tömítés típusa

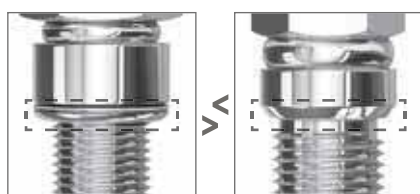

sík vagy kúpos

2 A menet átmérője



3 A hengerfej anyaga



Öntöttvas vagy Alumínium

1	Az ülék típusa	Gyújtógyertya sík ülékkel (tömítéssel)				Gyújtógyertya kúpos ülékkel	
2	Menet Ø	10 mm	12 mm	14 mm	18 mm	12/14 mm	18 mm
3	Vasöntvényből készült fej	10-15 Nm	15-25 Nm	25-35 Nm	35-45 Nm	15-25 Nm	20-30 Nm
	Könnyűfém (alumínium) fej	10-12 Nm	15-20 Nm	25-30 Nm	35-40 Nm	10-20 Nm	20-30 Nm

Alternatíva: Forgási szög részletek

A megfelelő forgásszög található a gyújtógyertya csomagolásán (Kivétel: verseny gyertyák - csak nyomaték módszer)

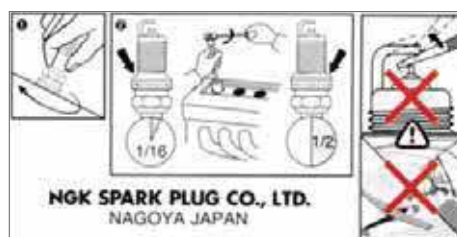



FONTOS ELTÁVOLÍTÁSI ÉS BESZERELÉSI TANÁCSOK IZZÍTÓGYERTYÁK

1 Lazítási / szakítási nyomaték



Az izzítógyertyák eltávolításakor mindig a megfelelő nyomatékot használja, nehogy túllépje a nyírási nyomatékot, így nem kell a letöréstől tartania.

Gyújtógyertya törési nyomaték

Ø Menet	M8	M9	M10	M12
Törési nyomaték	20 Nm	30 Nm	40 Nm	50 Nm

Megjegyzés: Más gyártók, mivel változó anyagú meneteket használnak, gyakran alacsonyabb szakítási nyomaték értékeket adnak meg. Ezért egy további, 5 Nm-rel még le kell csökkentenie ezt az értéket, ha nem ismeri az izzítógyertya gyártóját.

2 Tanácsok az eltávolításhoz

Ha az eltávolítás nem sürgős, javasoljuk, hogy a következők szerint járjon el:

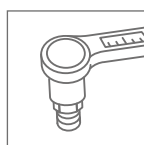
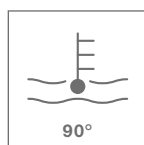

- > Spriccelje be az izzítógyertya ülekét a hengerfejnél szintetikus motorolajjal.
- > Hagyja egy pár napig, hogy az olaj beszívódjon, majd mozgassa meg a járművet.
- > Szerelje ki az izzítógyertyákat mialatt a motor még üzemi hőmérsékleten van ügyelve a törési nyomatékra és a megfelelő nyomaték-kulcsot használatával.

3 Tisztítás



Az új izzítógyertyák beszerelése előtt el kell távolítani az olaj és korom lerakódásokat az izzítógyertya furatából egy bezsírozott dörzsárral.

4 Gyújtógyertya beszerelési / meghúzási nyomatékok

Fémházas gyújtógyertyák						Kerámia gyújtógyertyák	
Ø Menet	M8	M9	M10	M12	M14	M8	M10
Meghúzási nyomaték	8,5Nm	11Nm	15Nm	23Nm	23Nm	10Nm	18Nm
Tűrészatár %-ban	+/- 10	+/- 10	+/- 10	+/- 10	+/- 10	+/- 10	+/- 10

Csatlakozó		
Ø Menet	M4	M5
Meghúzási nyomaték	0,8–1,5 Nm	3,0–4,0 Nm
Tűrészatár %-ban	+/- 10	+/- 10

! Ügyeljen a meghúzási nyomatékokra, ha ezeket a csomagoláson feltüntették! Az izzítógyertyák csak akkor működnek megfelelően, ha a megfelelő meghúzási nyomatékkal rögzítik őket!



ВАЖНЫЕ СОВЕТЫ ПО УСТАНОВКЕ СВЕЧЕЙ ЗАЖИГАНИЯ

Момент затяжки. Для компетентного монтажа свечи зажигания требуется динамометрический ключ, поскольку даже для специалистов почти невозможно оценить момент затяжки. Это связано с тем, что крутящий момент состоит из двух величин, умножаемых друг на друга: силы, воздействующей на соответствующий

центр вращения и длины рукоятки. Большинство поломок свечей зажигания происходит из-за неправильного момента затяжки. Если он будет слишком низким, возникнут потери компрессии и перегрев. Из-за вибрации может также сломаться изолятор или средний электрод. Если крутящий

момент будет слишком высоким, свеча зажигания может оторваться. Также может расширяться или деформироваться корпус. Нарушаются зоны теплоотведения, что чревато перегревом и оплавлением электродов, вплоть до поломки двигателя.

Моменты затяжки свечей зажигания

Требуемый момент затяжки зависит от типа посадки, диаметра резьбы и материала головки блока цилиндров. Соблюдайте моменты или углы затяжки, если они указаны на упаковке!

1 Тип посадки

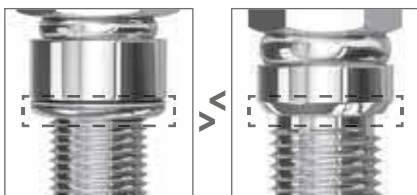

Плоская Или Коническая

2 Диаметр резьбы



3 Материал головки блока цилиндров

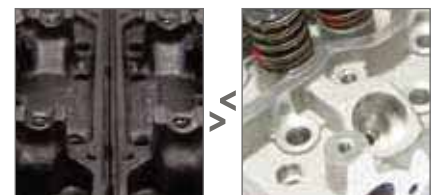

Чугун Или Алюминий

1	Тип посадки	Свеча зажигания с плоской посадкой (с уплотнительным кольцом)				Свеча зажигания с конической посадкой	
		10 мм	12 мм	14 мм	18 мм	12/14 мм	18 мм
2	Ø резьбы						
3	Чугунная головка блока цилиндров	10-15 Нм	15-25 Нм	25-35 Нм	35-45 Нм	15-25 Нм	20-30 Нм
	Алюминиевая головка блока цилиндров	10-12 Нм	15-20 Нм	25-30 Нм	35-40 Нм	10-20 Нм	20-30 Нм

Альтернативно: Данные по углу доворота

Соответствующий угол затяжки указан на упаковке. (Исключение: гоночные свечи - установка только с динамометрическим ключом)

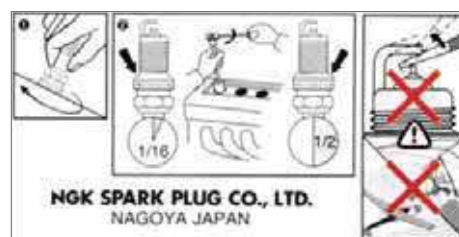



ВАЖНЫЕ УКАЗАНИЯ ПО СНЯТИЮ И УСТАНОВКЕ СВЕЧЕЙ НАКАЛИВАНИЯ

1 Снятие/моменты страгивания



Для замены свечей накаливания всегда нужно использовать подходящий динамометрический ключ, чтобы не превысить момент поломки (среза); в противном случае свеча будет сломана.

Моменты поломки (среза) свечей накаливания

Ø резьбы	M8	M9	M10	M12
Момент поломки (среза)	20 Нм	30 Нм	40 Нм	50 Нм

Внимание: Продукция конкурентов из-за использования других материалов и технологий обычно имеет меньший момент поломки (среза). Поэтому, если изготовитель свечей накаливания неизвестен, то значение нужно уменьшить на 5 Нм.

2 Советы по решению проблем при демонтаже

Если нет срочной необходимости замены, то рекомендуется следующий порядок действий:

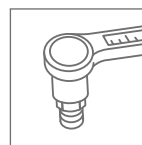
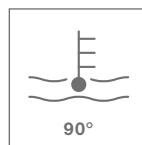

- > Смочить посадку свечи накаливания на переходе к ГБЦ синтетическим моторным маслом.
- > Оставить на несколько дней для просачивания масла в шахту свечи накаливания, эксплуатировать автомобиль как обычно.
- > Демонтировать свечу накаливания на прогревом до рабочей температуры двигателя с помощью подходящего динамометрического ключа.

3 Очистка



Перед установкой новых свечей накаливания с помощью римера (развертки), с нанесённой на него силиконовой смазкой, нужно удалить остатки масляного нагара и сажи из шахты свечи накаливания.

4 Установка/моменты затяжки свечей накаливания

Свеча накаливания с металлическим стержнем	Керамическая свеча накаливания							
	Ø резьбы	M8	M9	M10	M12	M14	M8	M10
Момент затяжки		8,5Нм	11Нм	15Нм	23Нм	23Нм	10Нм	18Нм
Допуск в %		+/- 10	+/- 10	+/- 10	+/- 10	+/- 10	+/- 10	+/- 10

Гайка терминала		
Ø резьбы	M4	M5
Момент затяжки	0,8–1,5Нм	3,0–4,0Нм
Допуск в %	+/- 10	+/- 10

! Соблюдайте моменты или углы затяжки, если они указаны на упаковке! Свечи накаливания работают безотказно, только если они ввернуты с правильным моментом затяжки!

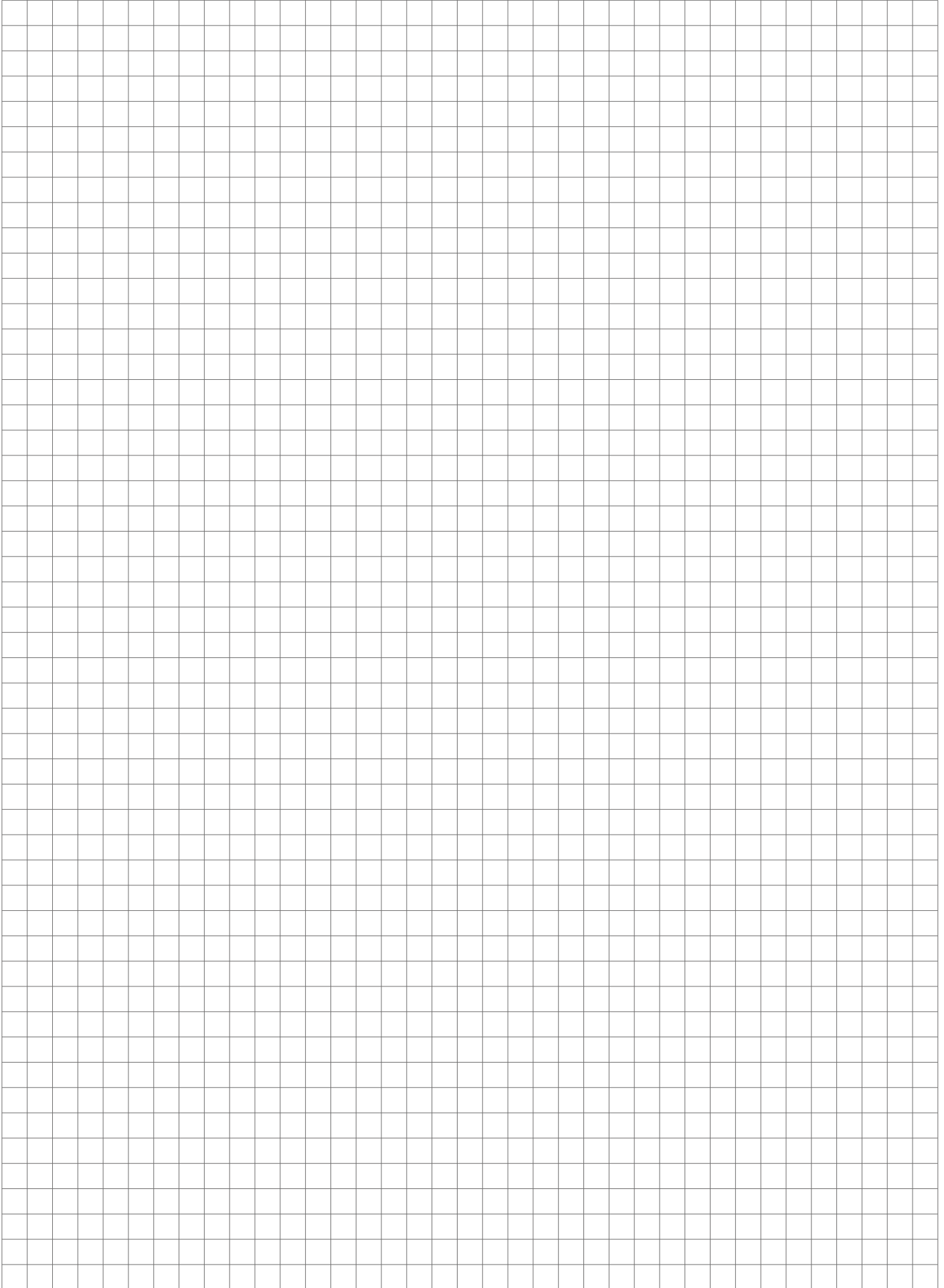

SERIES



IGNITION
PARTS

SERIES OF NGK SPARK PLUGS

NGK ZÜNDKERZEN · SÉRIES DES BOUGIES NGK

SERIES DE BUJÍAS DE ENCENDIDO NGK · TYPBETECKNINGAR FÖR NGK TÄNDSTIFT

STANDARD TYPES

STANDARD AUSFÜHRUNGEN
TIPOS ESTANDARES

TYPES STANDARDS
STANDARDTYPER

	NON-RESISTOR NON-RÉSISTANCE ICKERESISTOR	OHNE WIDERSTAND NO-RESISTOR	RESISTOR RÉSISTANCE RESISTOR	MIT WIDERSTAND RESISTOR
14mm x 9.5mm Hex 20.8mm Fig. ① ①	B-2 B-4 B6S B7S B8S		BR6S	
Fig. ① ③	BP-4 BP5S BP6S			
14mm x 19.0mm Hex 20.8mm Fig. ② ①	B4ES B5ES B6ES,-11 B7ES,-11 B8ES B9ES B10ES		BR4ES BR5ES BR6ES,-11 BR7ES BR8ES,-11 BR9ES BR10ES	
Fig. ② ②			BR6EB-L-11	
Fig. ② ④			BR8EYA BR9EYA BR10EYA	
Fig. ② ③	BP2ES, BP-2E BP4ES,-11 BP5ES,-11,-13 BP6ES,-11 BP7ES,-11 BP8ES BP9ES	BP5ESZ BP6ESZ	BPR2ES, BPR-2E BPR4ES,-11,-13 BPR5ES,-11,-13 BPR6ES,-5,-11 BPR7ES,-11 BPR8ES,-6 BPR9ES	
Fig. ③ ⑤			BPR6EKN BPR7EKN	
Fig. ② ⑥	BP4EY,-11 BP5EY,-11 BP6EY,-11 BP7EY		BPR4EY,-11 BPR5EY,-11 BPR6EY,-11 BPR7EY-11	
Fig. ② ⑦	BP5E BP6E		BPR4E,-11 BPR5E,-11 BPR6E,-11 BPR7E	
Fig. ④ ⑧	BP5ET,-10 BP6ET BP7ET			
Fig. ⑤ ⑨			BPR5EJ	
14mm x 19.0mm Hex 16.0mm Fig. ⑥ ③	BCP4ES,-11 BCP5ES,-11 BCP6ES,-11 BCP7ES,-11		BCPR5ES,-11 BCPR6ES,-11 BCPR7ES,-11 BCPR9ES-11	
Fig. ⑧ ⑨ ISO	BCP5ET BCP6ET BCP7ET		BCPR5ET BCPR6ET BCPR7ET	
Fig. ⑥ ①	BC6ES		BCR8ES	
Fig. ⑦ ③ ISO	BK5ES	BK5ESZ	BKR4ES-11 BKR5ES,-11 BKR6ES,-11 BKR7ES-11	

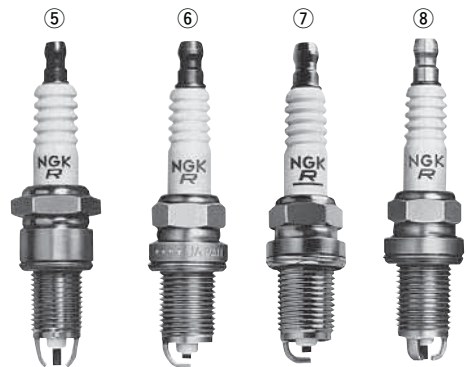
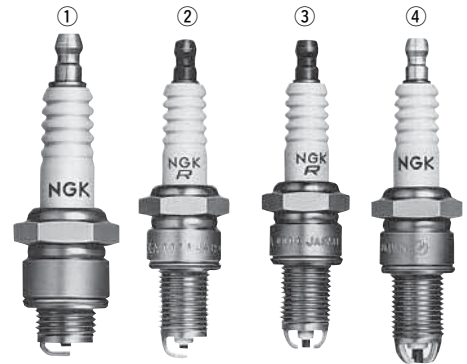

	NON-RESISTOR NON-RÉSISTANCE ICKERESISTOR	OHNE WIDERSTAND NO-RESISTOR	RESISTOR RÉSISTANCE RESISTOR	MIT WIDERSTAND RESISTOR
14mm x 19.0mm Hex 16.0mm Fig. ①③			BCPR4EY,-11 BCPR5EY,-11 BCPR6EY,-11,-N-11 BCPR7EY,-11,-N-11	
Fig. ②④ ISO			BKR4EY,-11 BKR5EY,-11 BKR5EYA,-11 BKR6EY,-11 BKR6EYA,-11 BKR7EY	
Fig. ①⑤	BCP5E BCP6E,-11 BCP7E,-11		BCPR5E,-11 BCPR6E,-11 BCPR7E,-11	
Fig. ②⑥ ISO	BK5E,-11 BK6E,-11		BKR4E,-11 BKR5E,-11,-N,-N-11 BKR5EZ BKR6E,-11-E,-N,-N-11 BKR6EZ BKR7E,-11,-N-11 BKR8E-11 FR6F-11DK FR6F-11K	
Fig. ⑥⑦ ISO			BKR5EK BKR6EK	
Fig. ⑥⑧ ISO			BKR5EKB-11 BKR6EKB-11	
			BKR5EKC BKR6EKC,-N-11 BKR6EKE BKR7EKC,-N,-N-11	
14mm x 26.5mm Hex 16.0mm Fig. ⑧④			LFR4A,-11 LFR4A-E LFR5A,-11 LFR6A,-11 LFR7A	
14mm x 11.2mm Conical seat Hex 16.0mm Fig. ③①	B7FS		BR5FS BR6FS,-15	
Fig. ③②	BP4FS BP5FS BP6FS BP7FS		BPR4FS,-11,-15 BPR5FS,-11,-15 BPR6FS	
Fig. ③④	BP5F BP6F			
14mm x 17.5mm Conical seat Hex 16.0mm Fig. ④①	B8EFS B9EFS		BR7EFS	
Fig. ④⑤			BR6EF BR7EF	
Fig. ④②	BP5EFS,-13 BP6EFS,-13 BP7EFS		BPR5EFS,-13 BPR6EFS,-13,-15 BPR7EFS-15	
Fig. ④④	BP6EF		BPR6EF,-11,-13	
14mm x 25.0mm Conical seat Hex 16.0mm Fig. ⑦②			TR5A-13 TR5B-13 TR6B-10	
14mm x 11.2mm Hex 20.8mm Fig. ⑤①	B-4L B-6L B6LY (Fig. ⑤⑤)			

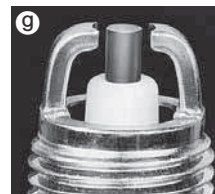
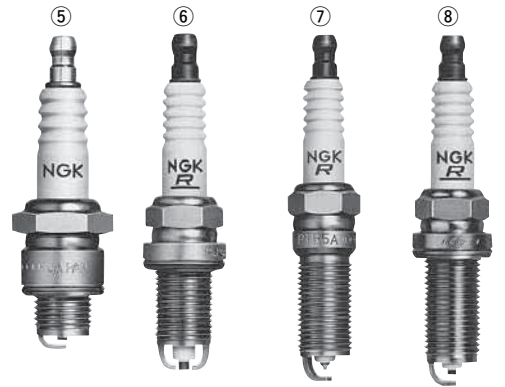
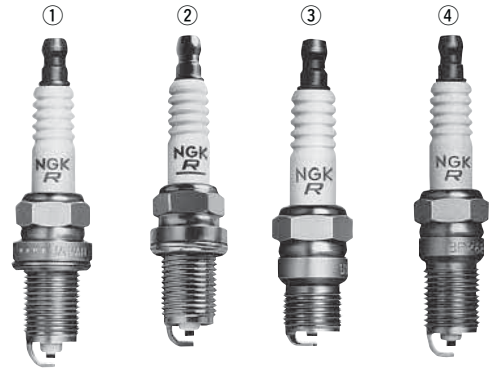

	NON-RESISTOR NON-RÉSISTANCE ICKERESISTOR	OHNE WIDERSTAND NO-RESISTOR	RESISTOR RÉSISTANCE RESISTOR	MIT WIDERSTAND RESISTOR
14mm x 12.7mm Hex 20.8mm Fig. ① a	B-2H B-4H,-10 B5HS B6HS,-10 B7HS,-10 B8HS,-10 B9HS B10HS		BR4HS BR5HS BR6HS,-10 BR7HS,-10 BZ7HS-10 BR8HS,-10 BR9HS,-10	
	Fig. ① b	BP2HS BP4HS,-10 BP5HS,-10 BP6HS,-10 BP6HSA BP7HS,-10 BP8HS,-10,-15	BP-2H BP-4H BP6H BP7H	BPR2HS BPR4HS,-10 BPR4HSA BPR-4H BPR5HS BPR6HS,-10 BPR6HSA BPR7HS,-10 BPZ8H-N-10 BPR8HS,-10 BPR8HSA BPZ8HS-10,-15
	Fig. ① c	BP4HA		
	Fig. ① e	B6HSA B8HSA		BR4HSA BR6HSA,-9 BR8HSA,-9
18mm x 12.0mm Hex 20.8mm Fig. ⑤ f	AB-2 AB-6 AB-7 AB-8			
18mm x 16.0mm Hex 25.4mm			R8102B-10	
12mm x 19.0mm Hex 18.0mm Fig. ⑥ h	D6EA D7EA D8EA D9EA D10EA		DR7EA DR7EB DR8EA DR8EB DR9EA	
	Fig. ⑥ i	DP6EA-9 DP7EA-9 DP8EA-9 DP9EA-9	DPR5EA-9 DPR6EA-9 DPR6EB-9 DPR7EA-9 DPR8EA-9 DPR9EA-9	
	Fig. ⑥ h	J9A		JR8B JR9B JR10B
	Fig. ⑥ k			JR8C JR9C
12mm x 21.0mm Hex 18.0mm Fig. ⑦ j	DP8Z		DPR7Z DPR8Z DPR9Z	
12mm x 19.0mm Hex 16.0mm Fig. ⑧ i	DCPR6E DCPR7E		DCPR6E KR6A-10 DCPR7E,-N DCPR8E,-N KR8C-G DCPR9E KR9C-G	
	Fig. ⑧ m			DCPR8EKC
12mm x 20.5mm Hex 16.0mm			KER7A-8DEG	
12mm x 26.5mm Hex 16.0mm Fig. ⑧ b			LKR6C LKR6E LKR6F-10 LKR7E	
12mm x 25.0mm Hex 14.0mm			LNAR7A-9G	
12mm x 26.5mm Hex 14.0mm Fig. ⑧ b			LZKAR6C-9 LZKAR7D-9,-9D LKAR8A-9,-9S	

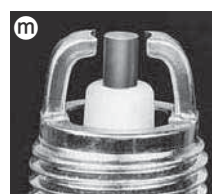
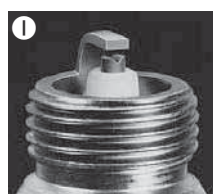
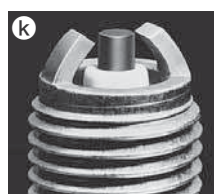
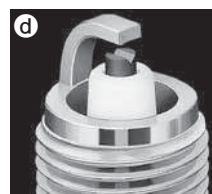
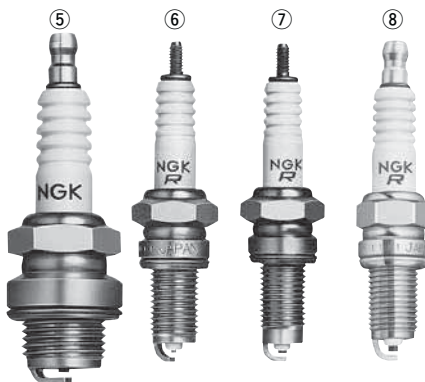

	NON-RESISTOR NON-RÉSISTANCE ICKERESISTOR	OHNE WIDERSTAND NO-RESISTOR	RESISTOR RÉSISTANCE RESISTOR	MIT WIDERSTAND RESISTOR
12mm x 12.7mm Hex 18.0mm Fig. ①a	D6HA D8HA		DR4HS DR5HS DR6HS DR8HS	
10mm x 12.7mm Hex 16.0mm Fig. ②a	C2H C5HSA C6HSA C7HSA C8HSA	C4HSB C5HSB	CR4HSA CR4HSB LR4C-E CR5HSA CR5HSB CR6HSA LR6E CR7HSA LR7D CR8HSA CMR8H LR8A LR8B	
10mm x 19.0mm Hex 16.0mm Fig. ③j	C7E C8E C9E		CR6E CR6EB CR7EK CR7EB CR8EK CR8EB CR9EK CR9EB CR10E	
Fig. ③k			D CPR6EA-9S CPR8E CPR7EA-9	
10mm x 19.0mm Hex 16.0mm Fig. ④a	C8EH-9 C9EH-9		CR5EH-9 MR7C-9N MR7E-9 MR7F CR8EH-9 MR8C-9N MR8D-9 MR8E-9 MR8F CR9EH-9 MR9C-9N	
10mm x 19.0mm Hex 16.0mm Fig. ③b			CR7EKB CR7EKB CR8EKB CR8EKB CR9EKB CR9EKB CR10EK	
Fig. ③i			CR7EKC	
10mm x 19.0mm Hex 14.0mm Fig. ⑤			MAR8B-JDS MAR9A-J MAR9B-JDS MAR10A-J	
10mm x 26.5mm Hex 14.0mm Fig. ⑥			LMAR6A-9 LMAR6C-9 LMAR7A-9 LMAR7H-9DS LMAR8A-7,9,9S LMAR8F-9 LMAR8G	
Fig. ⑥			LMAR9D-J	
8mm x 19.0mm Hex 13.0mm Fig. ⑤a			ER8EH, -N ER9EH, -N, -6N ER10EH	

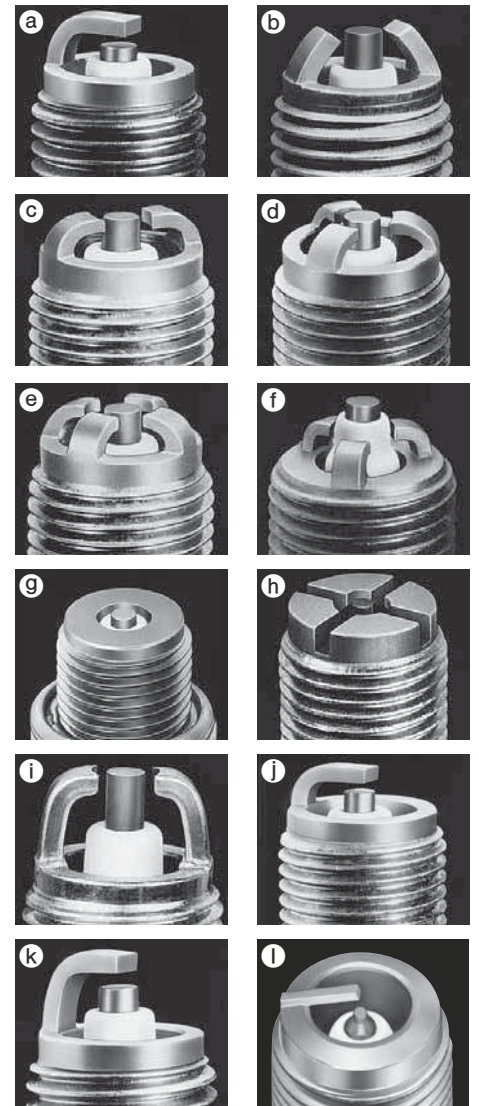
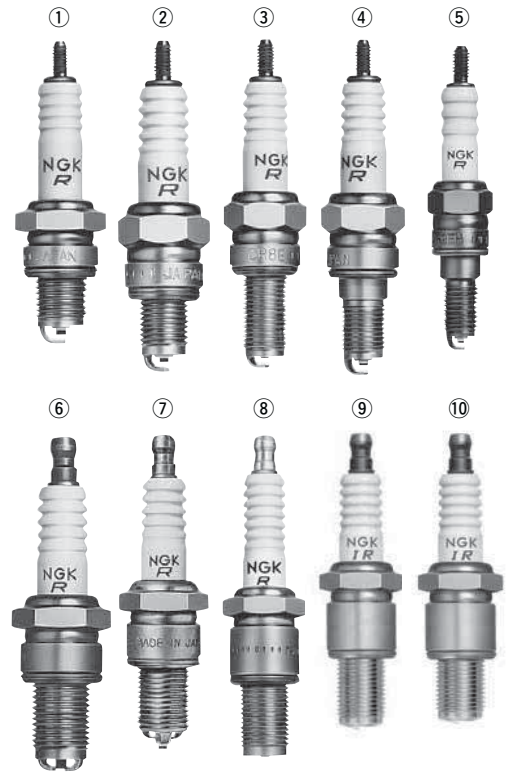

FOR ROTARY ENGINE
FÜR WANKELMOTOR **POUR MOTEUR ROTATIF**
PARA MOTOR ROTATIVO **TÄNDSTIFT FÜR WANKELMOTORER**

	NON-RESISTOR NON-RÉSISTANCE ICKERESISTOR	OHNE WIDERSTAND NO-RESISTOR	RESISTOR RÉSISTANCE RESISTOR	MIT WIDERSTAND RESISTOR
14mm x 19.5mm Hex 20.8mm Fig. ⑥c	B7EM		BR8EM	
Fig. ⑥d			BR7ET BR8ET BR9ET BR10ET	
Fig. ⑥e			BR8EQ,-14 BR9EQ,-14	
14mm x 21.5mm Hex 20.8mm Fig. ⑧g			SD10A SD11A	
Fig. ⑧h			BUR6EQ BUR7EQ BUR8EQ BUR9EQ BUR9EQ BUR9EQ	
14mm x 21.0mm Hex 20.8mm Fig. ⑨			RE6C-L RE7C-L RE8C-L	
14mm x 19.0mm Hex 20.8mm Fig. ⑩①			RE9B-T	

SEMI SURFACE DISCHARGE TYPES AND SUPPLEMENTARY GAP TYPE

HALBGLEITFUNKENTYPEN UND ZUSÄTZLICHER ABSTANDSTYP
 TYPE À DÉCHARGE SEMI-SURFACIQUE ET TYPE À ÉCARTEMENT SUPPLÉMENTAIRE
 TIPO DE DESCARGA DE MEDIA SUPERFICIE Y TIPO DE GALGA SUPLEMENTARIA
 STIFT MED SEMI-YTGNISTGAP OCH STIFT AV SUPPLEMENTÄR TYP

	NON-RESISTOR OHNE WIDERSTAND NON-RÉSISTANCE NO-RESISTOR ICKERESISTOR	RESISTOR MIT WIDERSTAND RÉSISTANCE RESISTOR RESISTOR
14mm x 12.7mm Hex 20.8mm Fig.①②	BU8H	BUZ8H
14mm x 19.0mm Hex 20.8mm Fig.②③		BUR5EA-11 BUR6EA-11 BUR7EA-11
14mm x 19.0mm Hex 20.8mm Fig.②④		BUR4EB-11 BUR5EB-11 BUR6EB-11 BUR7EB-11
	Fig.②⑤	BUR5ET,-10 BUR6ET
14mm x 19.0mm Hex 20.8mm Fig.③⑥		BPR6EK-A
	Fig.③⑦	BPR5EKU
14mm x 17.5mm Conical seat Hex 16.0mm Fig.④⑧	BU6EFSZ	BUR6EFSZ
14mm x 19.0mm Hex 16.0mm Fig.⑥⑨ ISO		BKUR6EK,-9 BKUR7EK
	Fig.⑤⑩ ISO	BKUR5ET,-10 BKUR5ETZ-10 BKUR6ET,-10 BKUR6ETB BKUR7ET
	Fig.⑥⑪ ISO	BKR5EKU BKR6EKU BKR7EKU
		BKR6EKUE
	Fig.⑥⑫ ISO	BKR6EKUB
14mm x 22.0mm Hex 16.0mm Fig.⑦⑬		BKR5EKUC BKR6EKUC
14mm x 19.0mm Hex 16.0mm Fig.⑥⑭		BKR6EQUA

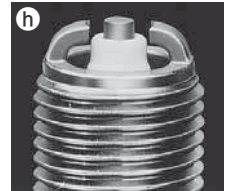
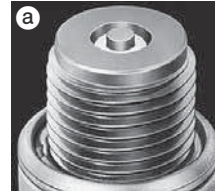
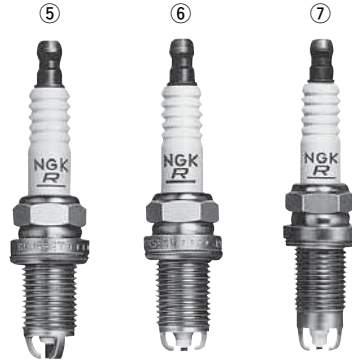
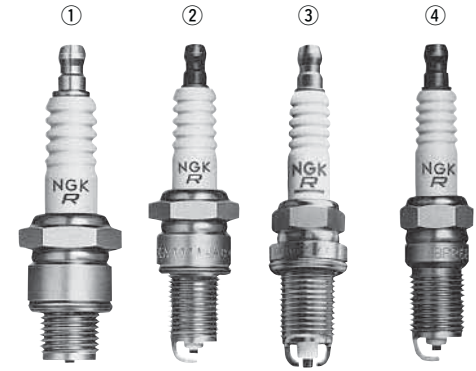

PROJECTED GAP TYPES

ZUNDKERZEN MIT VORSPRINGENDER FUNKENSTRECK

TYPE A ÉCARTEMENT EN SAILLIE

TIPOS DE ABERTURA DE CHISPA PROYECTADA

STIFT MED FÖRLÅNGDA ELEKTRODER

	NON-RESISTOR NON-RÉSISTANCE ICKERESISTOR	OHNE WIDERSTAND NO-RESISTOR	RESISTOR RÉSISTANCE RESISTOR	MIT WIDERSTAND RESISTOR	
14mm x 19.0mm Hex 20.8mm Fig. ①②	BE529Y-11		BRE527Y-11	BRE529Y,-11	
Fig. ②③			ZGR4A	ZGR5A	
14mm x 20.5mm Hex 20.8mm Fig. ②④			ZGR5B,-11	ZGR6B-11	
14mm x 22.0mm Hex 20.8mm Fig. ②⑤			ZGR5C		
14mm x 19.0mm Hex 16.0mm Fig. ③⑥	ZF6A-11		ZFR5A-11	ZFR6A-11	
Fig. ④⑦			ZFR4F-11	ZFR5F-11	ZFR5J-11
Fig. ③⑧			ZFR6F-11,G	ZFR6J-11	ZFR7J-11
14mm x 20.5mm Hex 16.0mm Fig. ③⑨			ZFR6K-9E,-11S		
14mm x 22.5mm Hex 16.0mm Fig. ③⑩			ZFR5G	ZFR6G	
14mm x 22.5mm Hex 16.0mm Fig. ③⑪			ZFR4E-11	ZFR5E-11	
Fig. ③⑫			ZFR6E-11	ZFR5D-11	
14mm x 25.0mm Conical seat Hex 16.0mm Fig. ⑤⑬			LZTR4A-11	LZTR5A-13	
12mm x 19.0mm Hex 16.0mm			ZKR7A-10		
12mm x 21.5mm Hex 16.0mm			ZKER6A-10DEG,-10EG		
12mm x 26.5mm Hex 16.0mm			LZKR6B-10E		
12mm x 26.5mm Hex 14.0mm			LZKAR6C-11		
12mm x 26.3mm Bi-Hex 14.0mm			ZKBR7A-HTU		

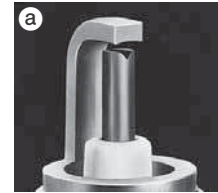
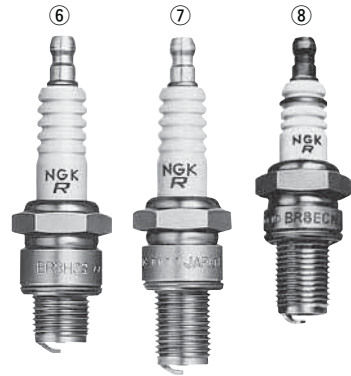
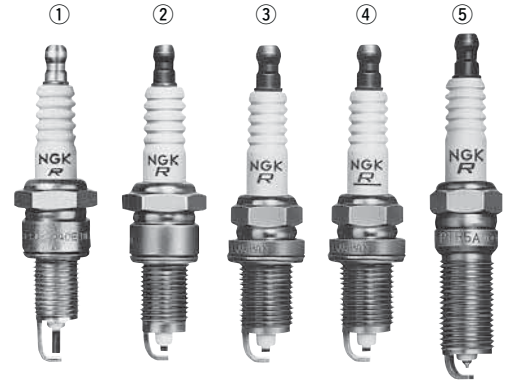

SLANT GROUND ELECTRODE TYPE

SCHRÄGER MASSENELEKTRODENTYP

TYPE À ÉLECTRODE DE MASSE À INCLINAISON

TIPO DE ELECTRODO DE MASA INCLINADO

STIFT MED VINKLAD SIDOELEKTROD

14mm x 12.7mm Hex 20.8mm Fig. ⑥⑬	B7HCS B8HCS B9HCS	BR8HCS-10
14mm x 19.0mm Hex 20.8mm Fig. ⑦⑭	B7ECS B8ECS B9ECS	BR8ECS BR9ECS BR10ECS
Fig. ⑧⑮		BR8ECM BR9ECM BR10ECM

PLATINUM, IRIIDIUM TIPPED TYPES
TYPEN MIT PLATINELEKTRODENSPITZE, IRIIDIUMSPITZE
TYPE[S] A EXTREMITÉ EN PLATINE, IRIIDIUM
TIPOS CON PUNTA DE PLATINO, IRIIDIO
STIFT MED MITTELEKTRODÄNDA AV PLATINA OCH IRIIDIUM

	RESISTOR MIT WIDERSTAND RÉSISTANCE RESISTOR RESISTOR
14mm x 19.0mm Hex 20.8mm Fig. ① ①	PGR5A,-11 PGR5C-11 BPR5EP-11,-13 PGR6A,-11 PGR6C-11 BPR6EP-8 PGR7A 125CX 126CX IGR7A
14mm x 19.0mm Hex 20.8mm Fig. ① ①h	IGR5C13 GR7CI-8
14mm x 19.0mm Hex 16.0mm Fig. ② ②a	PFR5A-11 PFR5K-11 BCPR5EP-8,-11,-13 PFR6A-11 PFR6H-10 PFR6K-11 BCPR6EP-8,N-8,-11,-N-11,-13 PFR7A-11 PFR7H-10
Fig. ③ ③h ISO	FR4AP-10,-11 FR4BP-11 FR5AP-10,-11 FR5BP-11 FR5AP-11E FR6AP-10,-11 FR6BP-11 FR7AP-11 115CX 116CX 136CX FR5EI-13 PFR5B-9,-11,-11B PFR5C-11 PFR6B,-9,-11,-11B,-11C PFR6E-10 PFR7B,-9,-11 PFR8B,-9 PFR4G-11 PFR5J-11 PFR5G-11,-13E PFR6H-10 PFR6J,-11 PFR6G,-9,-11,-13,-13E PFR7G,-9,-11 PFR7S11EG PFR5L-11 PFR5N-11,8DS PFR5P-11 PFR6L-11,-13 PFR6N-11 PFR6P-11 PFR6Q PFR7N-D PFR7Q PFR5R-11 BKR5EP-11 BKR6EP-8,-11,-13,-N-8
Fig. ④ ④c ISO	BKR6EKPA
Fig. ④ ④d ISO	BKR5EKUP
Fig. ④ ④e ISO	BKR5EKPB-11,-13 BKR6EKPB-11
Fig. ④ ④j ISO	BKR5EQUPA BKR6EQUP BKR6EQUPA
Fig. ③ ③f ISO	PFR6M PFR6X-11 PFR7M PFR7S8EG
Fig. ③ ③g ISO	PZFR5B PZFR5F,-11 IZFR5B IZFR5F11 IZFR5G IZFR5L11 PZFR6B PZFR6F,-11 IZFR6B IZFR6F11 SIFR6B7G T6728R T6728U-G035
Fig. ③ ③h ISO	IFR5A11,-8N IFR5D10 IFR5E11 IFR6A11 IFR6C IFR6D10 IFR6E11 IFR6AD7DG IFR6AE11S IFR7F-D IFR7B4D IFR8AF4D IFR8AG8 IFR5G11 IFR5J11 IFR5N10 IFR5T-8N,11 IFR6J11 IFR6S IFR6T11 IFR7X7G
Fig. ③	PZFR6H IZFR6J IZFR6N-E IZFR6Q
Fig. ③ ③m	PFR6W-TG
Fig. ③ ③n	DIFR5E11 DF6A-13B DIFR6D11D DIFR6D13 ZFR5LP-13G IZFER7A4D 11G-55
14mm x 21.5mm Hex 16.0mm	PZFR6R,8EG
14mm x 22.0mm Hex 16.0mm Fig. ⑩ ⑩k ISO	PZFR5C PZFR5D-11 IZFR5C IZFR7E-D
14mm x 22.5mm Hex 16.0mm	135CX
14mm x 25.0mm conical seat Hex 16.0mm Fig. ⑥ ⑥h	PTR5A-13 ILTR5D

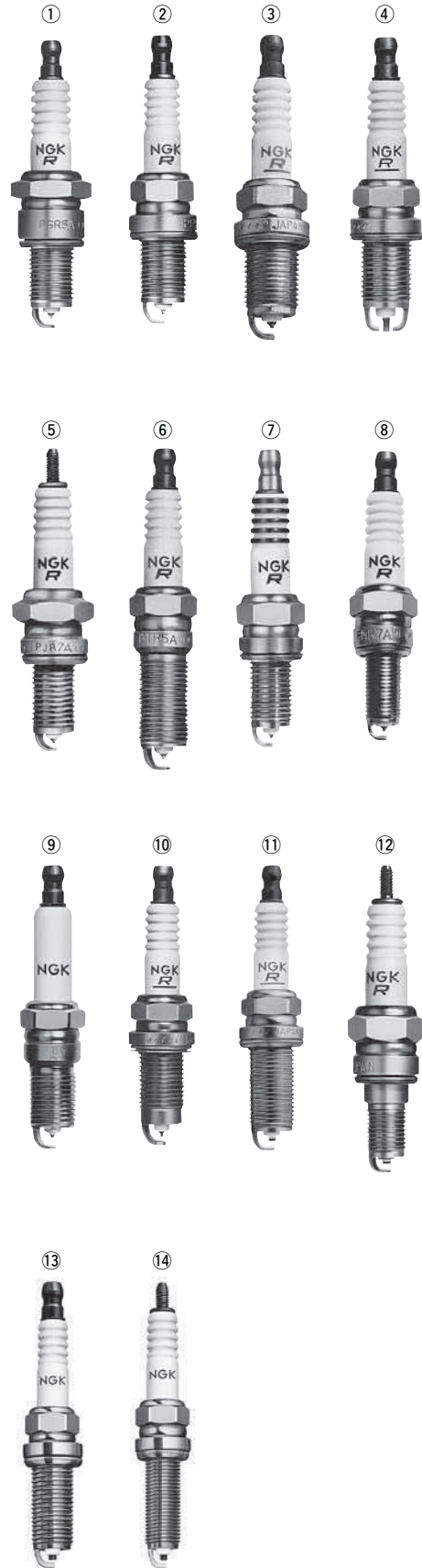

	RESISTOR MIT WIDERSTAND RÉSISTANCE RESISTOR RESISTOR
14mm x 17.5mm conical seat Hex 16.0mm Fig. ⑨①	PTR4B-15 PTR5C-13 ITR4A15 ITR6F13
14mm x 17.5mm conical seat Hex 16.0mm Fig. ③④⑧ Fig. ⑨⑨	ITR5H13 PTR5D-10,-13 TR5AI-13 TR5AP-13 ITR6G9 PTR6D-13,-13G ITR7J9D PZTR5A-15
14mm x 20.5mm Hex 16.0mm Fig. ③⑫	IZFR6K11,11E,13 IZFR6K-11S,IZFR6K11NS PZFR7G-G
14mm x 21.5mm Hex 16.0mm Fig. ⑭	PZFR5N-11T
14mm x 22.0mm Hex 16.0mm Fig.	PZFR6J-11
14mm x 26.5mm Hex 16.0mm Fig. ⑪	PLFR4A-11 PLFR5A-9,-11 ILFR5T11 ILFR5B11 DILFR5A11 DILFR5C11 DILFR5E11 DF5B-8A DILFR5L11 ILZFR5E8D LZFR5CI-11 PLFR6A-9,-11 ILFR6T11 ILFR6K8 ILFR6G,-E SILFR6A11 DILFR6D11D DILFR6L11 PLFR7A-9 DILFR7K9G ILFER7A8EG SILZFR7A9G PLZFR6A-11S ILZFR6A11 DILFR7B10G 155CX 156CX
14mm x 28.0mm Hex 16.0mm Fig. ⑪	LZFR5BI-11 LZFR5DI-11 LZFR6AI
14mm x 29.5mm Hex 16.0mm Fig. ⑪①	LZFR5AQP
14mm x 25.0mm conical seat Hex 16.0mm	PLZTR4A-13 PLZTR5A-13 ILTR5A-13G ILTR5P11D LTR5BI-13 LTR6AP-11 ILTR6A-8G,-13G ILTR6J13 ILTR6M9G LTR6AI-8 LTR6BI-13 LTR6BI-9 LTR6DI-8 LTR6DP13 ILTR7E9D ILTR7J8 ILTR7N8 ILTR7Q9 LTR7CP13
12mm x 19.0mm Hex 18.0mm Fig. ⑤⑧	PJR6A PJR7A IJR7A9 PJR8A
12mm x 19.0mm Hex 16.0mm	IKR6G8 IKR7H8 IZKR8C10D SIKR8B7G IKR9H8 IKR9J8 147CX
12mm x 19.0mm Hex 16.0mm Fig. ⑦①	PKR7A KR7AI IKR6G11 PKR9B KR8AI KR9CI IKR9F8
12mm x 19.0mm Hex 16.0mm Fig. ⑦②	DCPR8EKP
12mm x 20.5mm Hex 16.0mm	IKER7A8EGS ZKR7BI-10 PKER7A8EGS PKER7A8DES
12mm x 21.5mm Hex 16.0mm	PZKER7B8EGS
12mm x 22.0mm Hex 16.0mm	IZKR7A
12mm x 26.5mm Hex 16.0mm	ILKR6F11 ILZKR6F11 SILKR6C10E SILKR6D10G ILKR7D8 ILKR7J8 ILKR7K8 ILKR7L8G ILZKR7D8 ILZKR7E10DG LKR7FI-8 SILKR7C8DE SILZKR7E11 SILZKR7E8EG SILZKR7E9 SILZKR7E9G SILZKR7G8DE ILKR8M5D ILKR8P8 SILZKR8E3D SILZKR8E8G ILKR9G8 ILKR9H8 HKS-G40XL
Fig. ⑩	DILKR7E11
Fig.	
12mm x 28.0mm Hex 16.0mm	DILZKR7B11G ILZKR7G7G
12mm x 29.0mm Hex 16.0mm	SILZKKER8A8E
12mm x 25.0mm Hex 14.0mm	SILZNR6D9 SILNAR7B7 SILNAR7C7DG ILNAR8B7G ILZNR8B7G SILNAR8A7
12mm x 26.5mm Hex 14.0mm	ILKAR7L11 ILKAR7L11D ILKAR7M10 ILZKAR7D11 LKAR7CI-8 ILKAR8H6 LKAR8CI-8 SILKAR8C6DG SILKAR8C6DS SILKAR8D6 SILKAR8E4DG SILKAR8F8 SILZKAR8D4D SILZKFR8B7S SILZNR8C7H HKS-M50HL
Fig. ⑬④	LKAR8AP7JD LKAR8AP7JDS
Fig. ⑬⑤	DILKAR7B8 DILKAR7G11DS DILKAR7H11GS DILKAR7M8 DILZKAR7B11 DILKAR8J9G DILKAR8K8D DILKAR8L8D
Fig. ⑬	

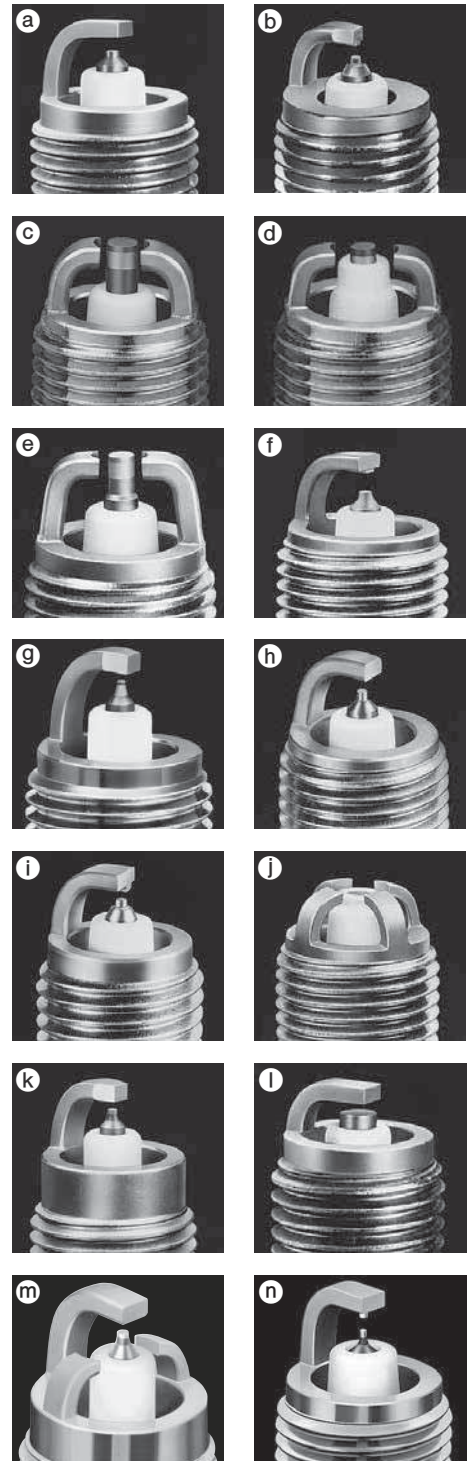

	RESISTOR MIT WIDERSTAND RÉSISTANCE RESISTOR RESISTOR
12mm x 27.0mm Hex 14.0mm	SILZKFR8C7S SILZKFR8D7S
12mm x 27.5mm Hex 14.0mm	SILZKFR8E7S
12mm x 28.0mm Hex 14.0mm Fig. (K)	DILZKAR7C11S ILZKAR7E11S ILZKAR8F8S ILZKAR8G8 ILZKAR8H8S ILZKAR8J8SY ILZKAR8A7G SILZKAR8F7S
12mm x 28.5mm Hex 14.0mm Fig. (N)	DILKA7E9HS
10mm x 19.0mm Hex 16.0mm Fig. (8) (i)	CR9EBI-9
Fig. (8)	MR8CI-8 SIMR7B9DS
Fig. (8) (C)	MR8BI-8
10mm x 19.0mm Hex 16.0mm Fig. (12)	
10mm x 22.0mm Hex 16.0mm	MR8BP8HJS
10mm x 26.5mm Hex 14.0mm Fig. (14)	ILMAR7B8 LMAR7CI-8 SILMAR7D9DS ILMAR8C9D LMAR8AI-8E LMAR8BI-9 SILMAR8C9 SILMFR8A8G SILMAR9B9
10mm x 26.5mm Hex 14.0mm Fig. (d)	LMAR9AP8JS
12mm x 26.5mm Bi-Hex 14.0mm	ILZKBR7B8DG PLZKBR7B8DG SILZKBR8B8HG SILKGR9A7EG
12mm x 27.5mm Bi-Hex 14.0mm	SILZKBR8D8S SILZKBR8E8S SILZKGR8A8S SILZKGR8B8S
12mm x 28.0mm Bi-Hex 14.0mm	SILZKG8D7E
12mm x 28.5mm Bi-Hex 14.0mm	SILZKBR8F8S SILZKGR8C8S

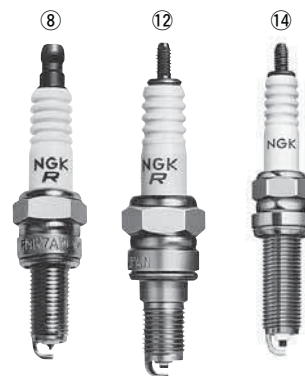

COMPACT TYPES

KOMPAKT STIFT
TIPOS COMPACTOS

TYPES COMPACTES
KOMPACTE TYPEN

	NON-RESISTOR NON-RÉSISTANCE ICKERESISTOR	OHNE WIDERSTAND NO-RESISTOR	RESISTOR RÉSISTANCE RESISTOR	MIT WIDERSTAND RESISTOR
18mm x 16mm Hex 25.4mm	R8160B-10			
14mm x 9.5mm Hex 19.0mm Fig. ①a	BM4A BM6A BM7A	B2-LM * B4-LM * BM6 * BM7 * * Hex.20.8mm	BMR2A,-10 BMR4A BMR6A BMR7A	BR2-LM * BR4-LM * * Hex.20.8mm
Fig. ①b	BPM4A BPM6A,-10 BPM7A		BPMR4A,-10 BPMR6A,-10 BPMR7A,-9	
14mm x 12.7mm Hex 20.8mm Fig. ②a	BL-6H			
14mm x 7.8mm Conical seat Hex 16.0mm Fig. ③a	BM6F BM7F	BM6FY	BMR6F	
Fig. ③b	BPM6F BPM7F		BPMR6F	
10mm x 8.6mm Hex 14.0mm Fig. ④a	CM-6			
10mm x 9.5mm Hex 16.0mm Fig. ⑧a			CMR6A CMR7A	
10mm x 12.7mm Hex 16.0mm Fig. ⑧e			CMR5H CMR6H CMR7H	
14mm x 9.5mm Hex 19.0mm Fig. ①c	BPM6Y BPM7Y BPM8Y		BPMR6Y BPMR7Y BPMR8Y	

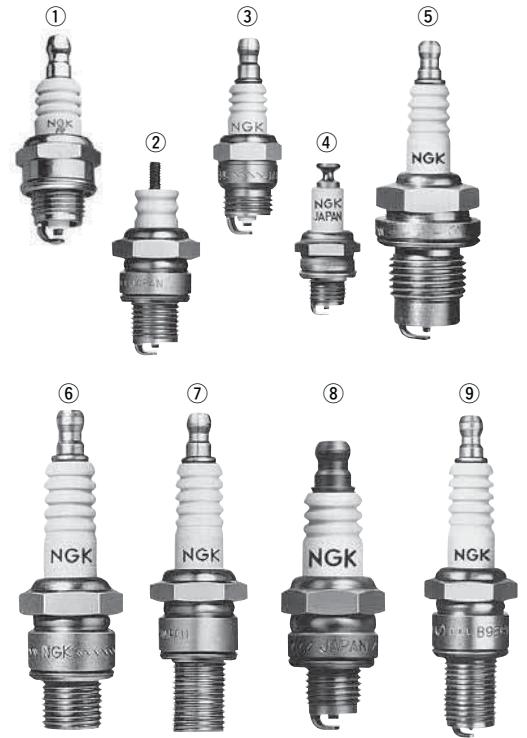

FARM EQUIPMENT TYPES

LANDMASCHINEN TYPEN
TIPOS MÁQUINAS AGRÍCOLAS

TYPES MACHINES AGRICOLES
FOR JORDBRUKS-MASKINER

PF1/2" x 22.5mm Hex 23.8mm Fig. ⑤d	G-27 G-2Z
--	----------------------------

SURFACE DISCHARGE TYPES

GLEITFUNKENTYPEN

TYPE À DÉCHARGE SUPERFICIELLE

TIPO DESCARGA EN SUPERFICIE TÅNDSTIFT MED YTGNI-STGAP

14mm x 12.7mm Hex 20.8mm Fig. ⑥f	BUHX(Series gap) BUHXW-1(Series gap)	
	BUH	
	BUHW BUHW-2	BUZHW BUZHW-2
14mm x 19.0mm Hex 20.8mm Fig. ⑦f	BUE	

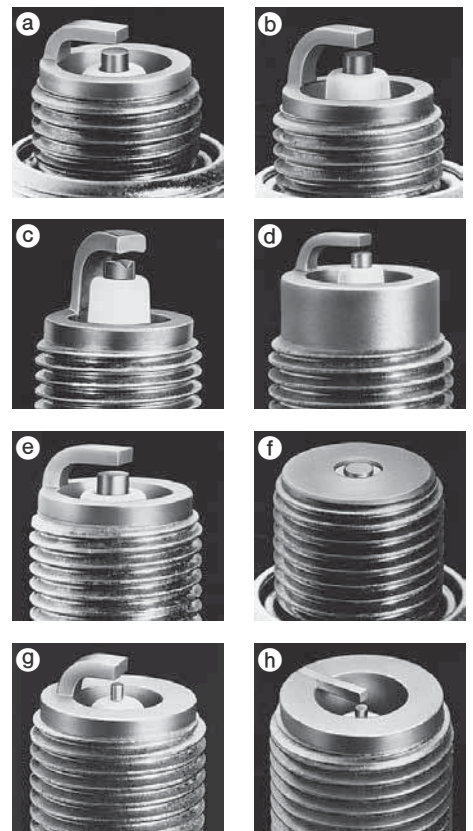

RACING TYPES

RENN-TYPEN

TYPES COURS

TIPOS DE CARRERAS

RACERSTIFT

	Nickel electrode Nickel Elektrode Electrodo de nickel Electrodo de níquel Nickel elektrod	Precious metal electrode Elektrode mit sonde-redel metall Electrodo en metal precieux Electrodo de metal precioso Ädelmetall elektrod	Platinum electrode Platinel Ektrode Electrodo de platine Electrodo de platino Platina elektrod
14mm x 19.0mm Hex 20.8mm	(Fig. ⑨g) B8EGV BR8EG* B9EGV BR9EG* B10EGP BR10EG*	(Fig. ⑨g) B8EGV B85EGV B9EGV B95EGV B10EGV B105EGV B11EGV	(Fig. ⑨h) B10EGP
*Resistor Type	B11EG		

IX TYPES

IX TYPEN TYPES IX
TIPOS IX IX-STIFT

	RESISTOR RÉSISTANCE RESISTOR	MIT WIDERSTAND RESISTOR	
18mm x 10.9mm Hex 20.8mm Fig. ① a	WR5IX		
14mm x 19.0mm Hex 20.8mm Fig. ② b	GR4IX GR5IX		
	Fig. ② c	BR7EIX BR8EIX BR9EIX BR10EIX	
	Fig. ② d	BR8ECSIX BR9ECSIX,-5	
	Fig. ③ d	BR8ECMIX BR9ECMIX BR10ECMIX	
14mm x 12.7mm Hex 20.8mm Fig. ④ b	BPR6HIX BPR7HIX BPR8HIX		
	Fig. ④ c	BR6HIX BR7HIX BR8HIX BR9HIX BR10HIX	
14mm x 9.5mm Hex 20.8mm Fig. ⑤ a	XR4IX XR5IX XR45IX		
14mm x 19.0mm Hex 16.0mm Fig. ⑥ b	BCPR7EDIX		
	Fig. ⑦ b	BCPR5EIX,-11 BCPR6EIX,-11 BCPR7EIX,-11	
	Fig. ⑧ b	BKR4EIX BKR5EIX,-11 BKR6EIX,-11 BKR7EIX,-11 BKR8EIX BKR9EIX	
Fig. ⑧ e	ZFR5FIX-11 ZFR6FIX-11		
14mm x 26.5mm Hex 16.0mm Fig. ⑨ b	LFR5AIX-11 LFR6AIX-11 LFR7AIX	LKR6AIX LKR7AIX LKR6AIX-P LKR6CIX	
14mm x 17.5mm Conical seat Hex 16.0mm Fig. ⑩ b	BPR6EFIX-10,-15		
	Fig. ⑩ a	TR4IX TR5IX TR6IX TR7IX TR8IX	TR55IX TR65IX TR75IX TR85IX
14mm x 20.5mm Conical seat Hex 16.0mm Fig. ⑪ e	TR5-1IX	TR45-1IX TR55-1IX	
14mm x 11.2mm Conical seat Hex 16.0mm Fig. ⑫ c	YR5IX YR55IX		
	Fig. ⑫ a	BR6FIX	UR4IX UR5IX UR6IX
14mm x 25.0mm Conical seat Hex 16.0mm Fig. ⑬ b	LTR5IX-11 LTR6IX-11 LTR7IX-11		
	Fig. ⑬ e	LZTR4AIX-11 LZTR5AIX-13 LZTR6AIX-13 LZTR7AIX-13	

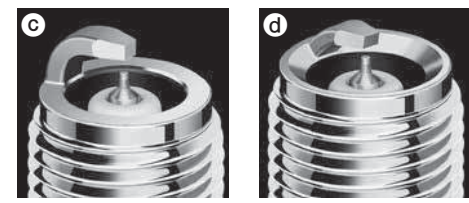
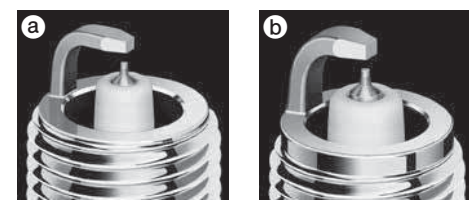
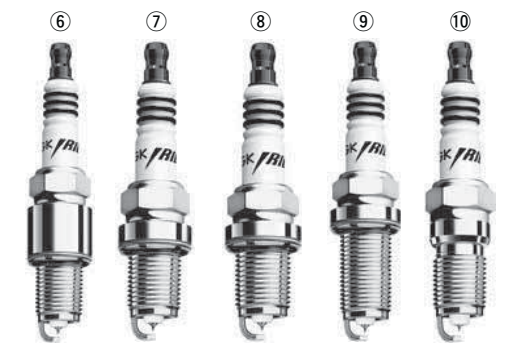

IX TYPES

IX TYPEN TYPES IX
TIPOS IX IX-STIFT

	RESISTOR MIT WIDERSTAND RÉSISTANCE RESISTOR RESISTOR
12mm x 19.0mm Hex 16.0mm Fig. ① a	DCPR6EIX DCPR7EIX DCPR8EIX DCPR9EIX
Fig. ① b	DCR7EIX DCR8EIX DCR9EIX
12mm x 19.0mm Hex 18.0mm Fig. ② a	DPR7EIX-9 DPR8EIX-9 DPR9EIX-9
Fig. ② b	DR7EIX DR8EIX DR9EIX
12mm x 21.0mm Hex 18.0mm Fig. ③ a	DPR8ZIX
12mm x 26.5mm Conical seat Hex 14.0mm Fig. ④ d	ZNAR7AIX ZNAR6AIX-11
12mm x 26.5mm Hex 14.0mm	LZKR6AIX
10mm x 19.0mm Hex 16.0mm Fig. ⑤ a	CPR6EAIX-9S CPR7EAIX-9 CPR9EAIX-9
Fig. ⑤ c	CR7EIX CR8EIX CR9EIX CR10EIX
Fig. ⑥ b	CR8EHIX-9 CR9EHIX-9
10mm x 12.7mm Hex 16.0mm Fig. ⑦ b	CR5HIX CR6HIX CR7HIX CR8HIX CR9HIX
8mm x 19.0mm Hex 13.0mm Fig. ⑧ e	ER8EHIX ER9EHIX

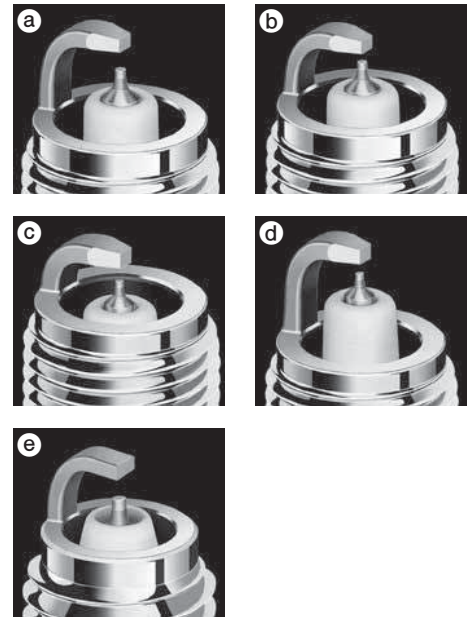
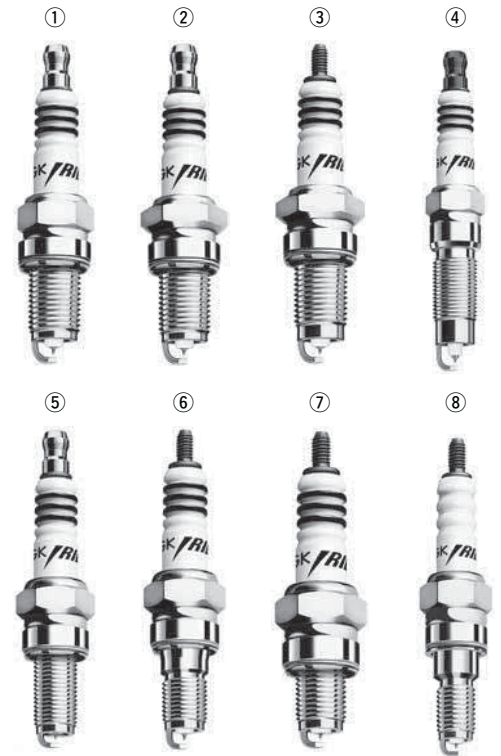

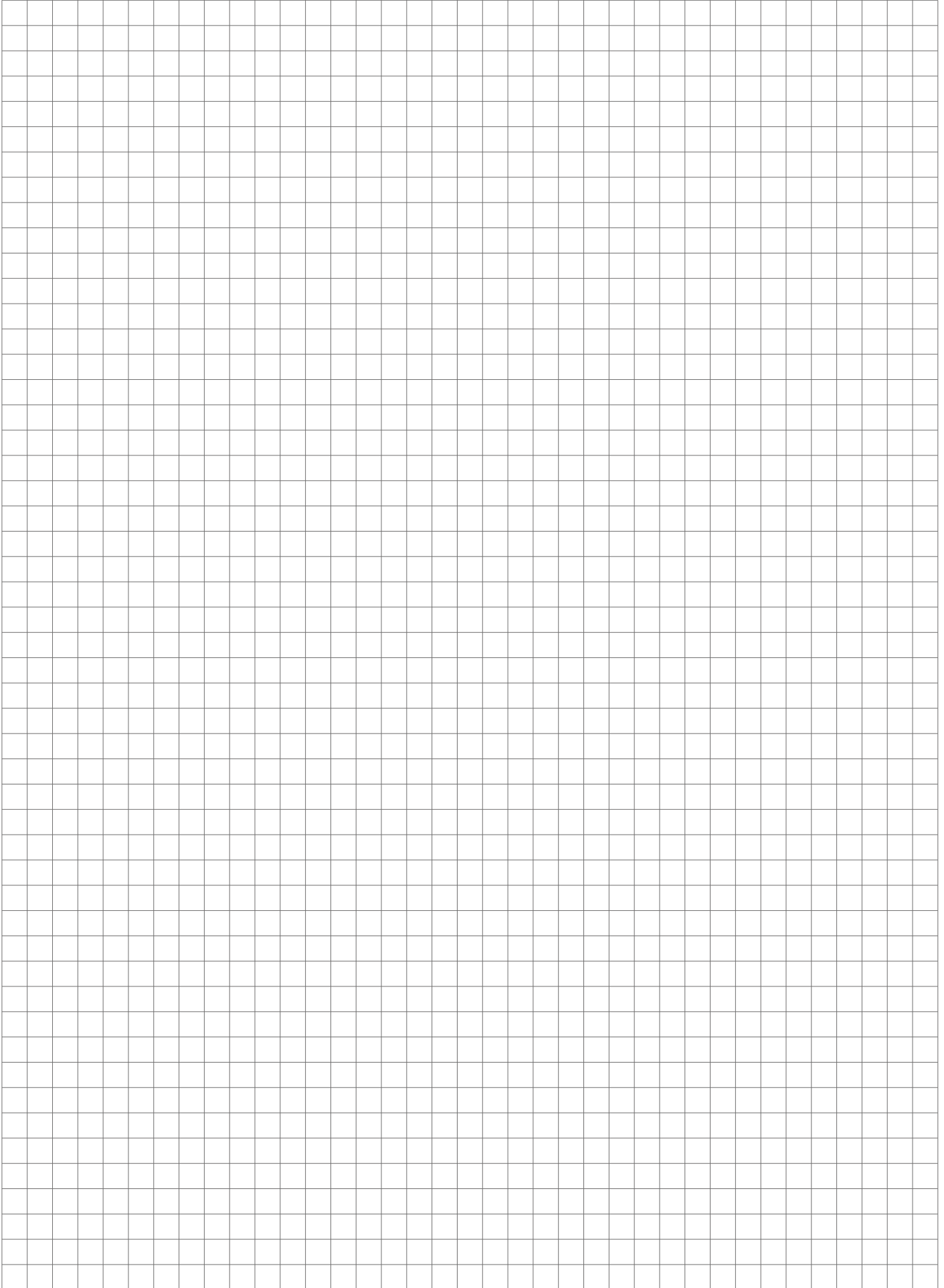

SERIES



IGNITION
PARTS

SERIES OF NGK GLOW PLUGS

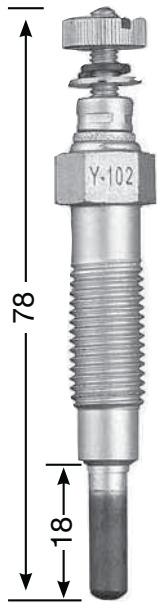

Y-102

M 10 x 1.25
12 Hex
10,5 V

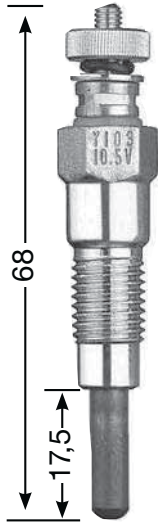

Y-103

M 10 x 1.25
12 Hex
10,5 V

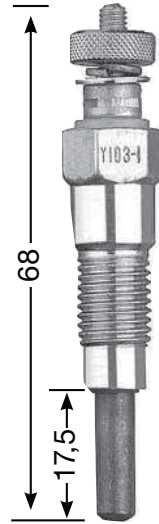

Y-103-1

M 10 x 1.25
12 Hex

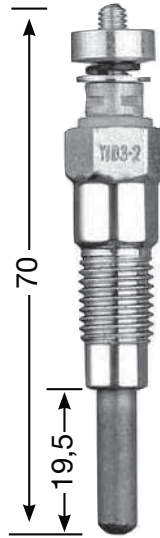

Y-103-2

M 10 x 1.25
12 Hex



Y-103 K

M 10 x 1.25
12 Hex
10,5 V

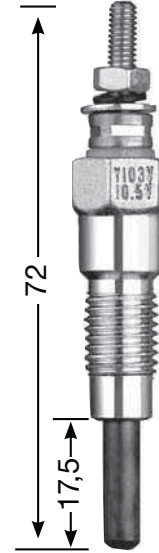

Y-103 V

M 10 x 1.25
12 Hex
10,5 V

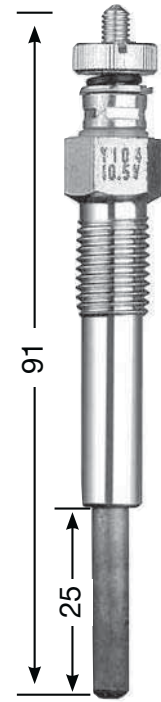

Y-104

M 10 x 1.25
12 Hex
10,5 V

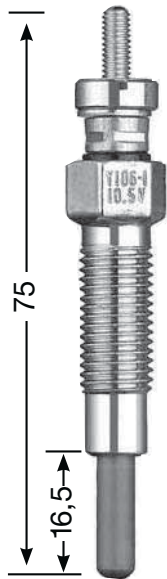

Y-106-1

M 10 x 1.25
12 Hex
10,5 V



Y-106 V

M 10 x 1.25
12 Hex
10,5 V

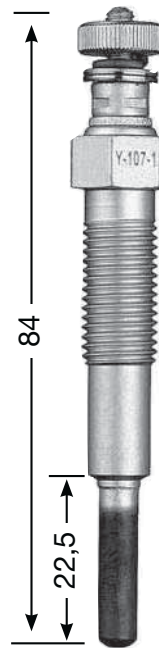

Y-107-1

M 10 x 1.25
12 Hex
10,5 V

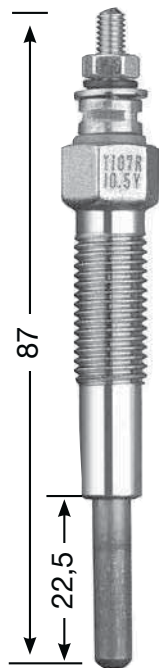

Y-107 R

M 10 x 1.25
12 Hex
10,5 V

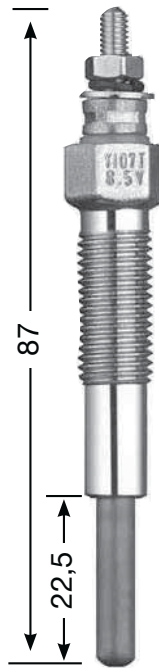

Y-107 T

M 10 x 1.25
12 Hex
8,5 V

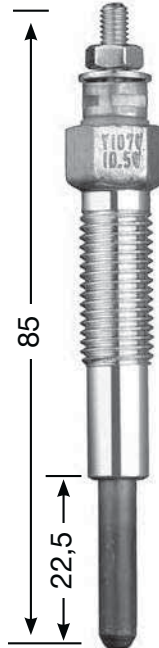

Y-107 V

M 10 x 1.25
12 Hex
10,5 V

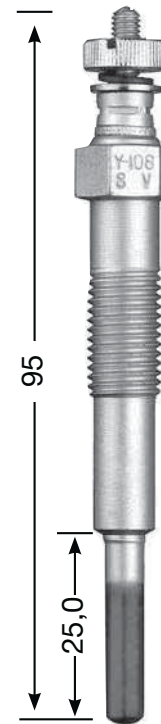

Y-108

M 10 x 1.25
12 Hex
8 V

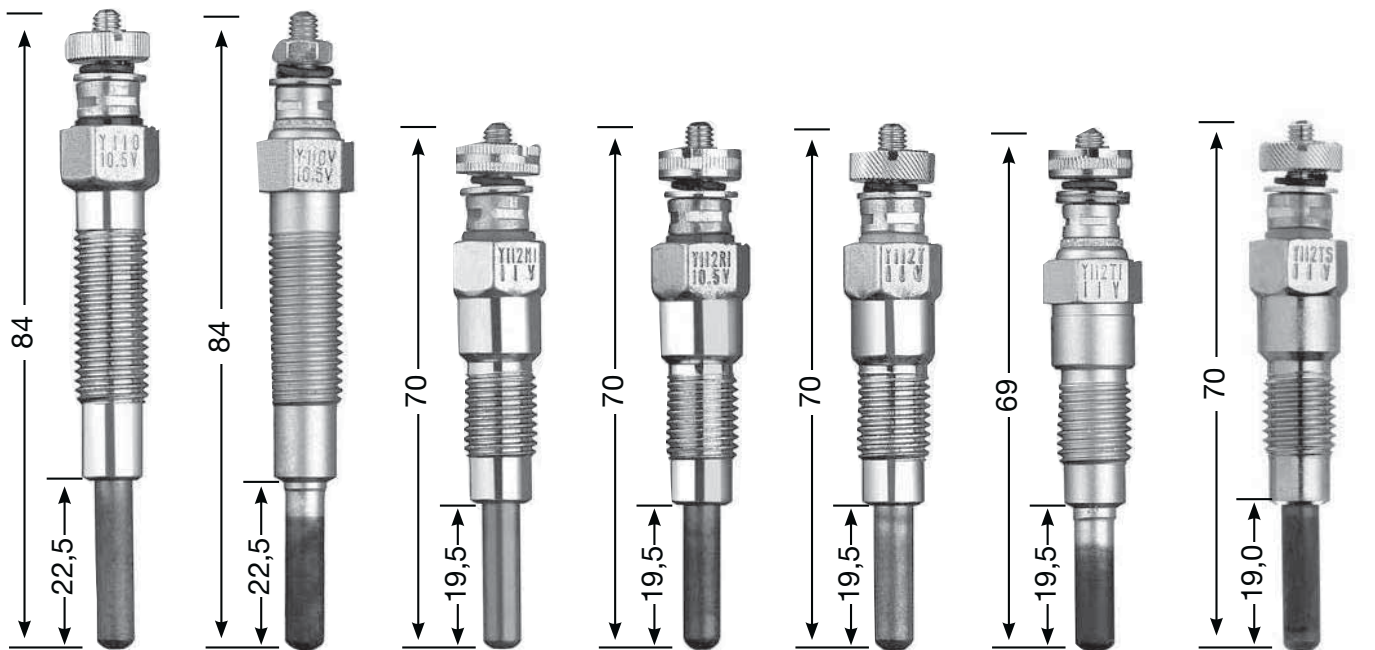

Y-110 M 10 x 1.25 12 Hex 10,5 V	Y-110 V M 10 x 1.25 12 Hex 10,5 V	Y-112 M1 M 10 x 1.25 12 Hex 11 V	Y-112 R1 M 10 x 1.25 12 Hex 10.5 V	Y-112 T M 10 x 1.25 12 Hex 11 V	Y-112 T1 M 10 x 1.25 12 Hex 11 V	Y-112 TS M 10 x 1.25 12 Hex 11 V
---	---	--	--	---	--	--

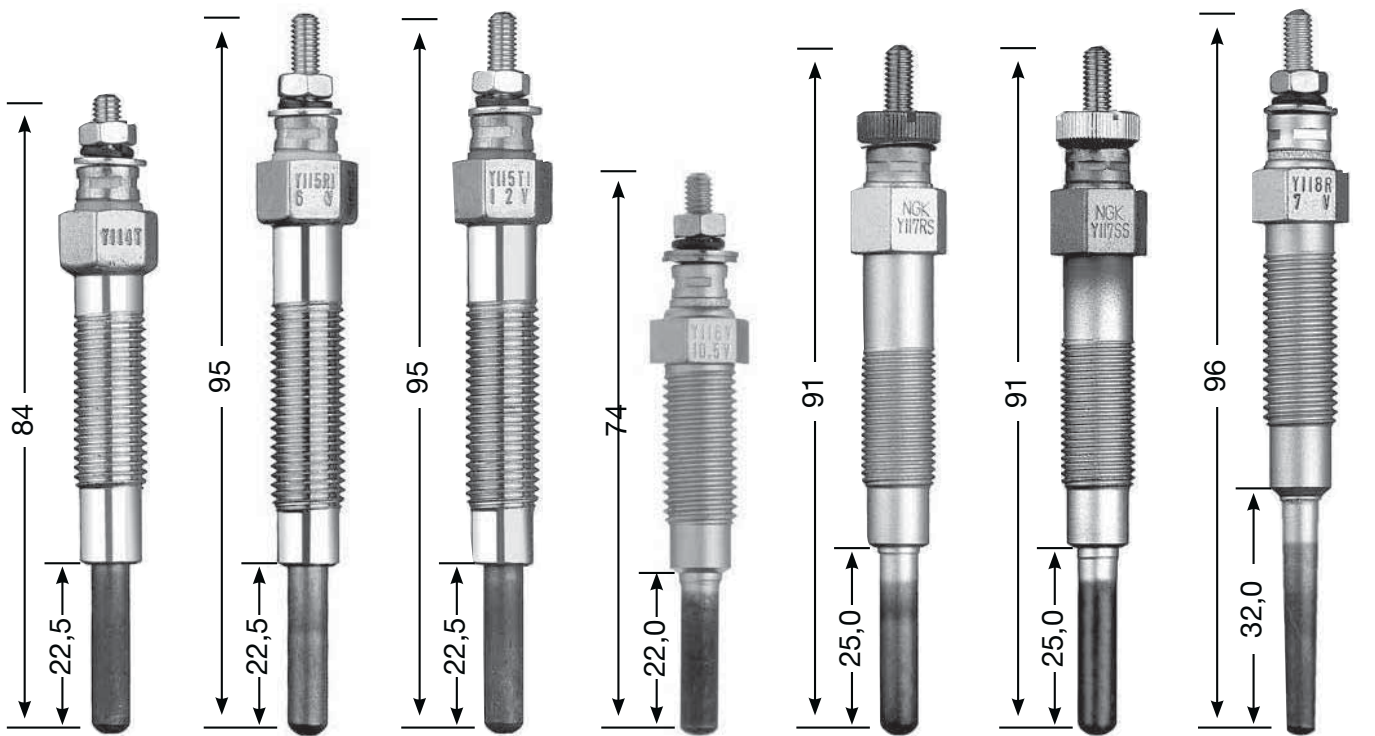

Y-114 T M 10 x 1.25 12 Hex 10,5 V	Y-115 R1 M 10 x 1.25 12 Hex 6 V	Y-115 T1 M 10 x 1.25 12 Hex 12 V	Y-116 V M 10 x 1.25 12 Hex 10,5 V	Y-117 RS M 10 x 1 12 Hex 6,5 V	Y-117 SS M 10 x 1 12 Hex 8,5 V	Y-118 R M 10 x 1.25 12 Hex 7 V
---	---	--	---	--	--	--

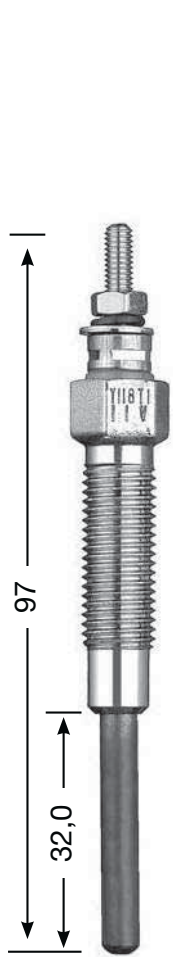

Y-118 T1
M 10 x 1.25
12 Hex
11 V

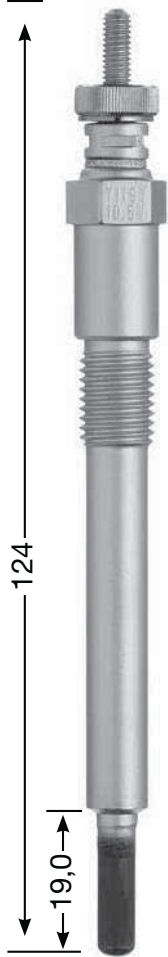

Y-119 V
M 10 x 1.25
12 Hex
10,5 V

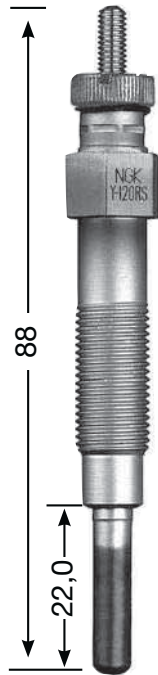

Y-120 RS
M 10 x 1.0
12 Hex
6,5 V

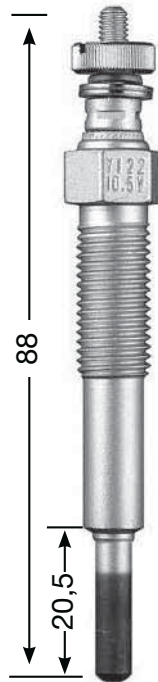

Y-122
M 10 x 1.25
12 Hex
10,5 V

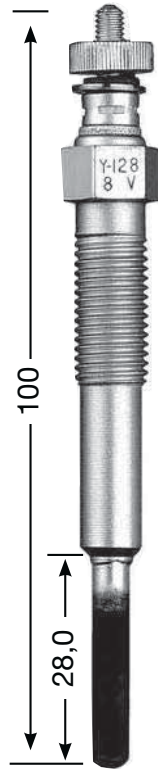

Y-128
M 10 x 1.25
12 Hex
8 V

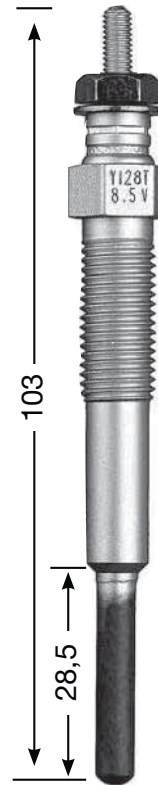

Y-128 T
M 10 x 1.25
12 Hex
8,5 V

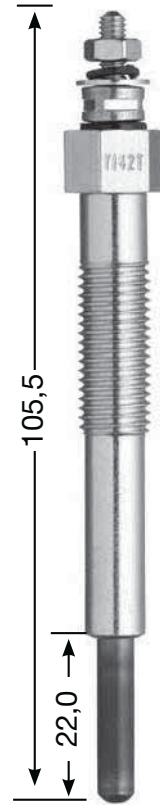

Y-142 T
M 10 x 1.25
12 Hex

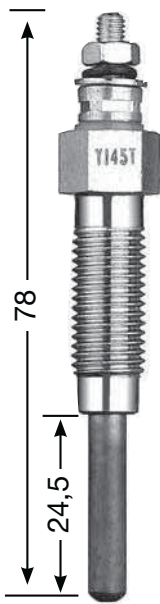

Y-145 T
M 10 x 1.25
12 Hex
10,5 V

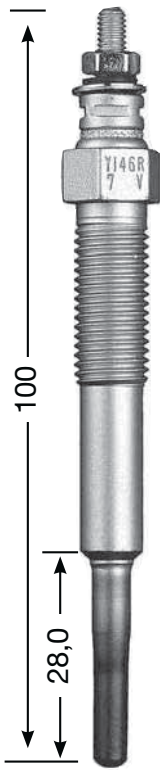

Y-146 R
M 10 x 1.25
12 Hex
7 V

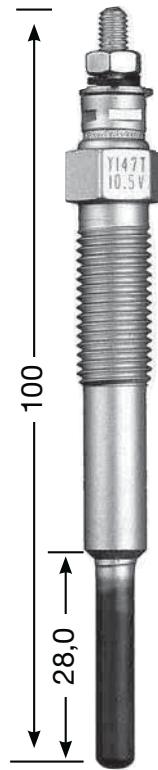

Y-147 T
M 10 x 1.25
12 Hex
10,5 V



Y-149
M 10 x 1.25
12 Hex
12,5 V



Y-157 R
M 10 x 1.25
12 Hex
23 V

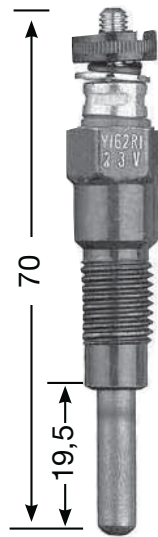

Y-162 R1
M 10 x 1.25
12 Hex
23 V

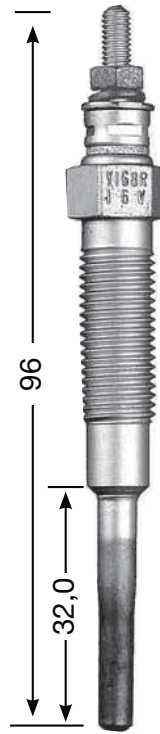

Y-168 R
M 10 x 1.25
12 Hex
16 V

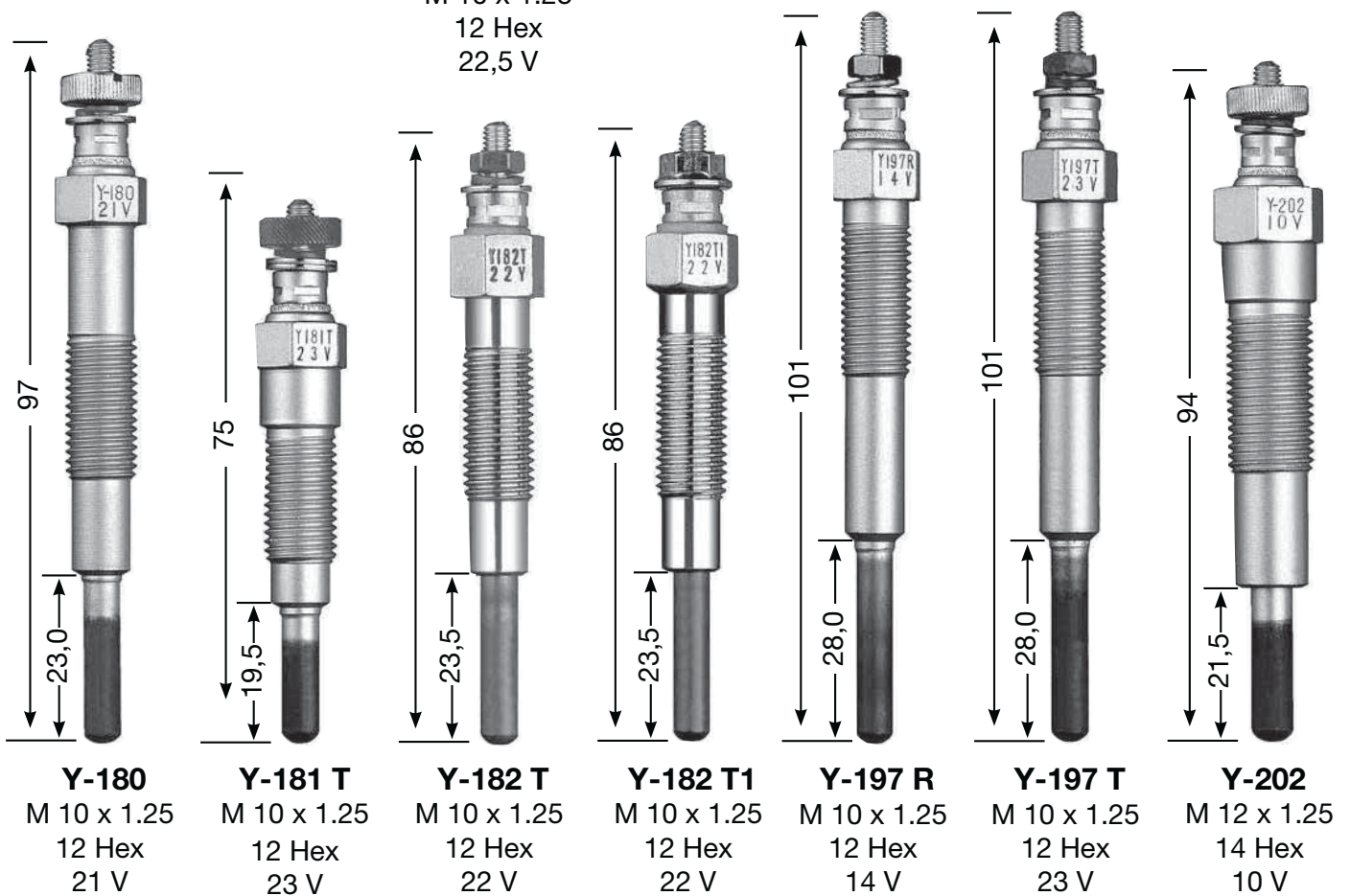
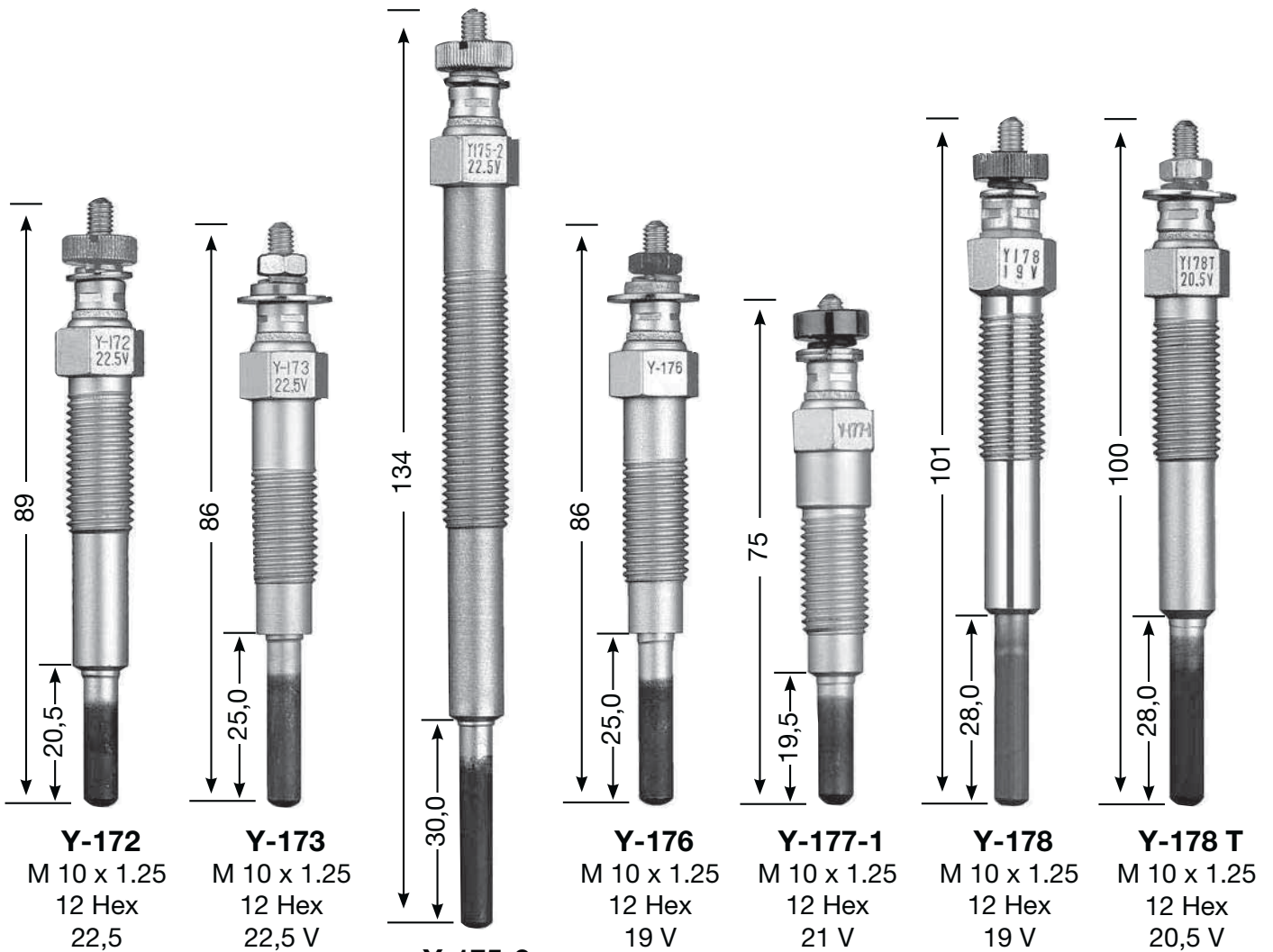

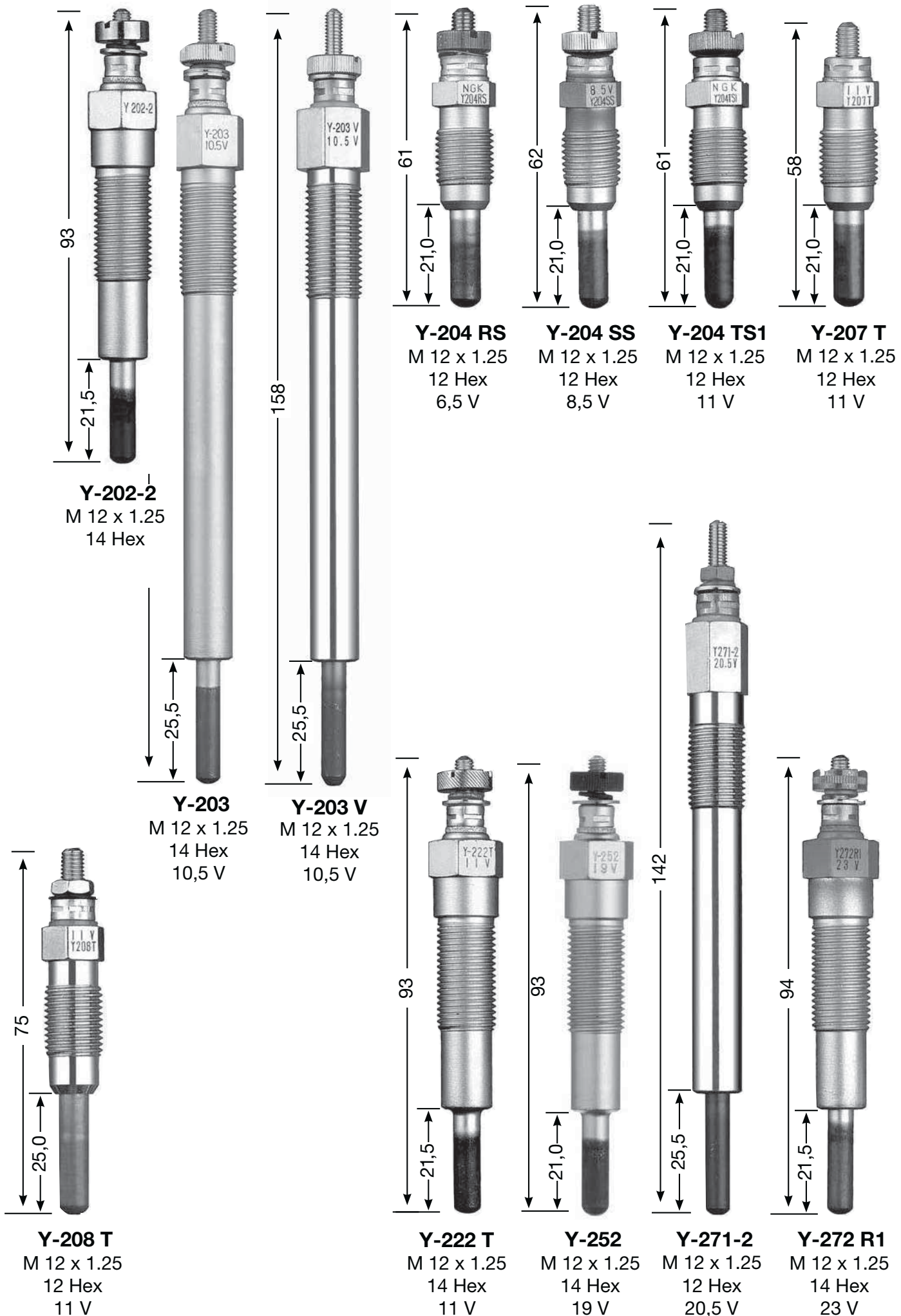

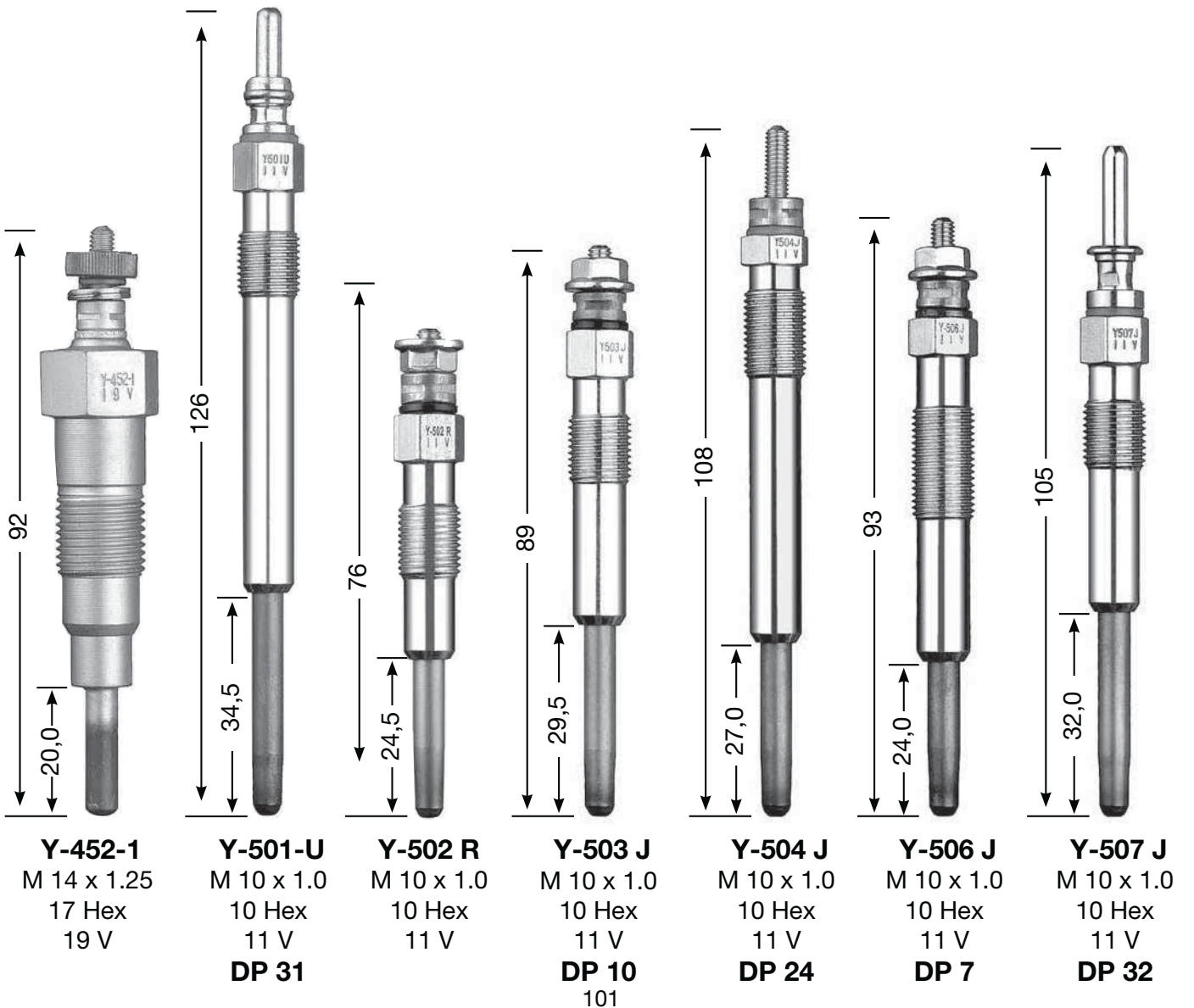
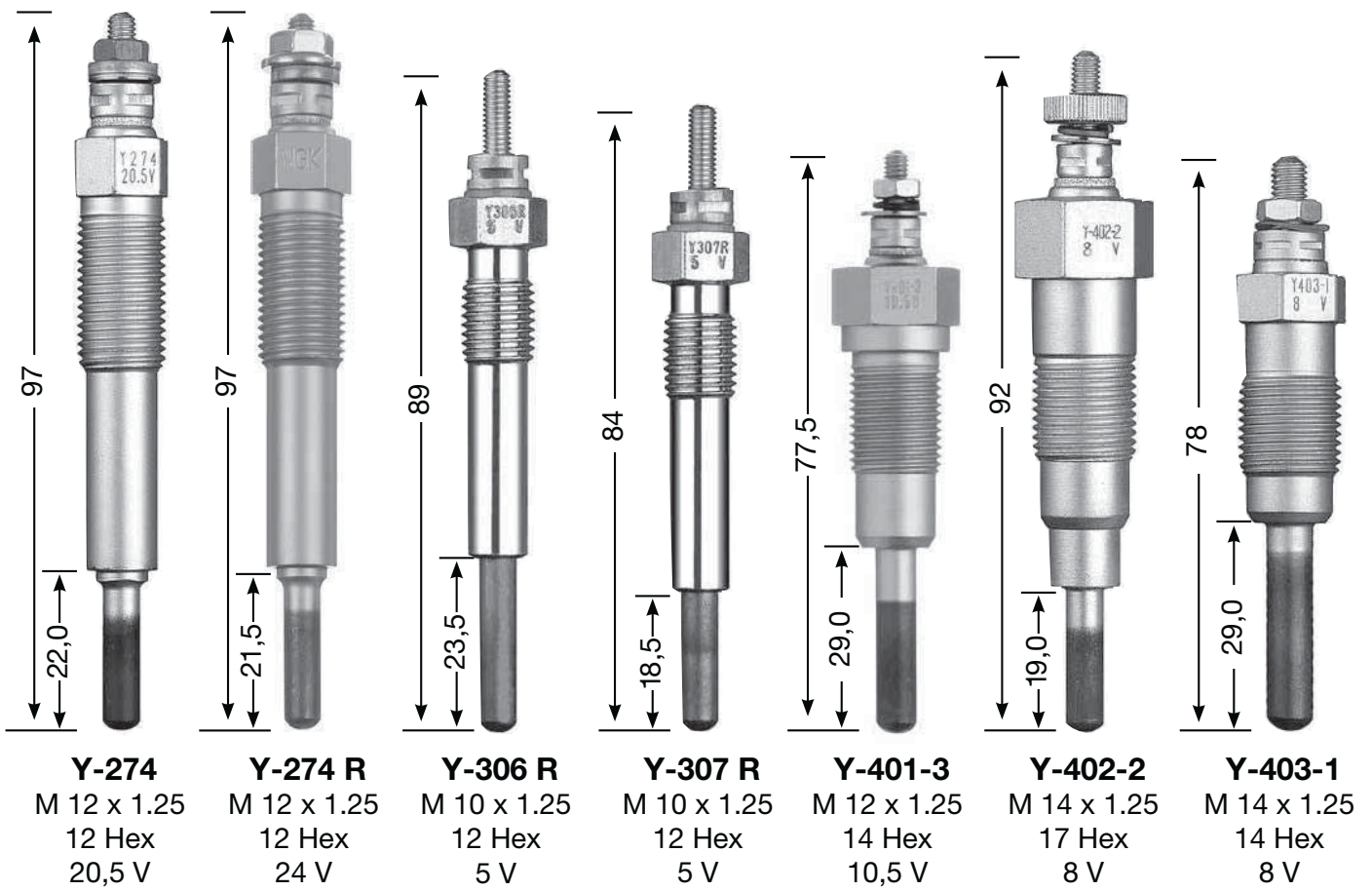

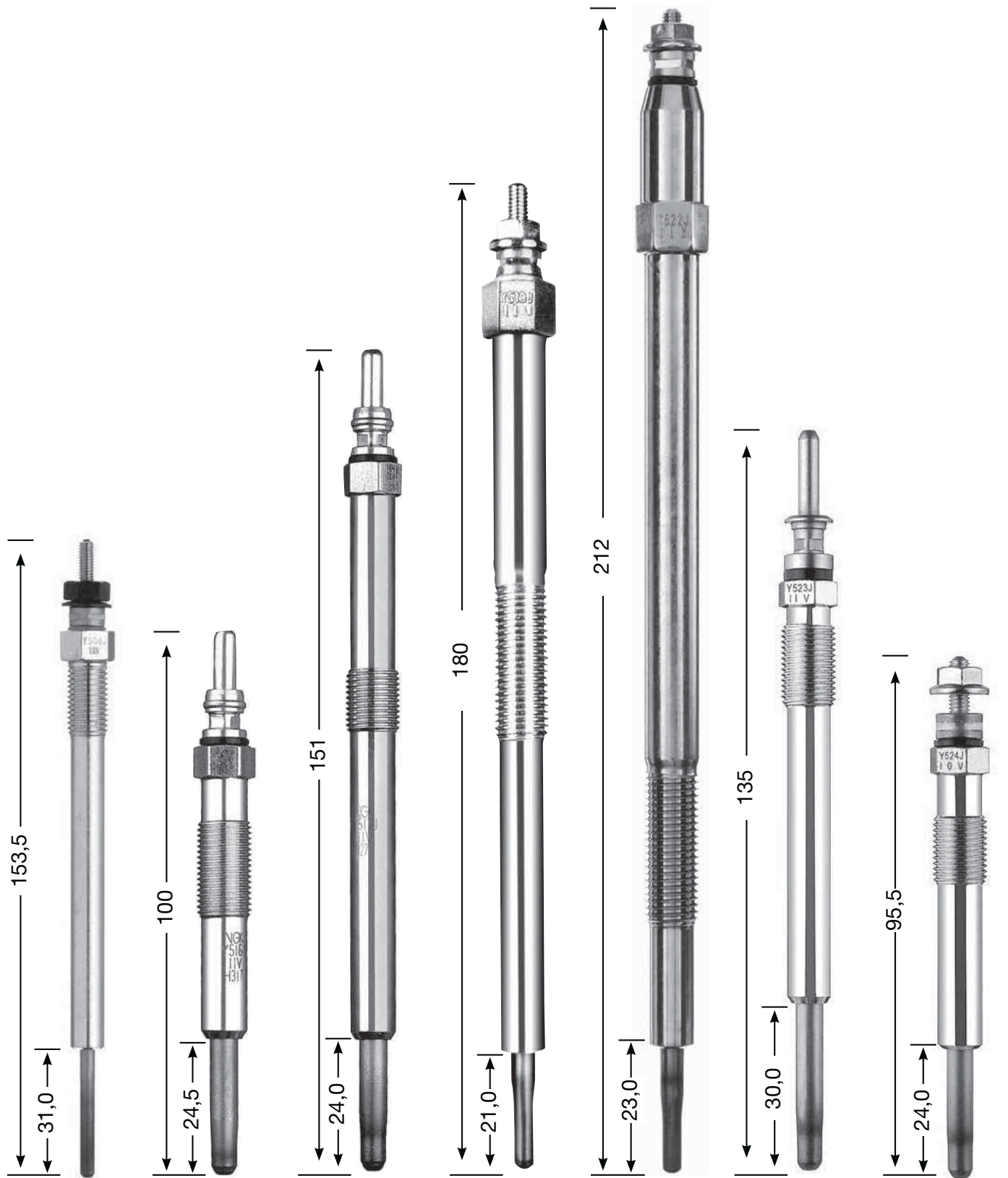

Y-508 J
M 10 x 1.25
12 Hex
11 V

Y-516 J
M 10 x 1.0
10 Hex
11 V
DP 12

Y-517 J
M 10 x 1.0
10 Hex
11 V

Y-519 J
M 12 x 1.0
10 Hex
11 V
DP 61

Y-522 J
M 10 x 1.25
12 Hex
11 V

Y-523 J
M 10 x 1.0
10 Hex
11 V
DP 37

Y-524 J
M 10 x 1.0
10 Hex
10 V
DP 27



Y-526 J1
 M 10 x 1.25
 12 Hex
 11 V
DP 69



Y-527 J
 M 10 x 1.25
 12 Hex
 11 V
DP 67

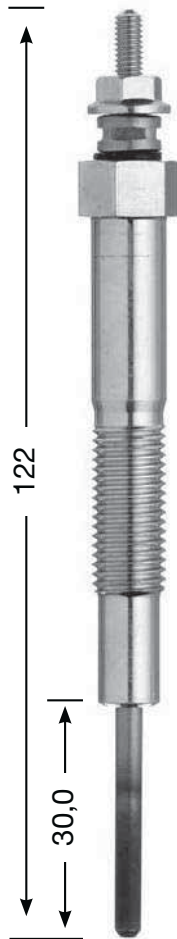

Y-529 J
 M 10 x 1.25
 12 Hex
 11 V

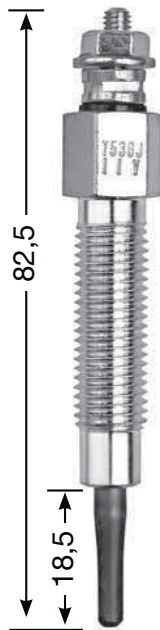

Y-530 J
 M 10 x 1.25
 12 Hex
 11 V



Y-531 J
 M 10 x 1.25
 12 Hex
 11 V
DP 44



Y-532 J
 M 10 x 1.25
 12 Hex
 11 V

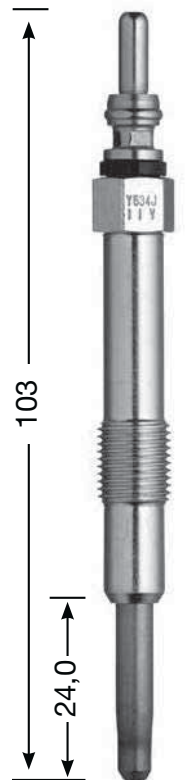

Y-534 J
 M 10 x 1.0
 10 Hex
 11 V
DP 36

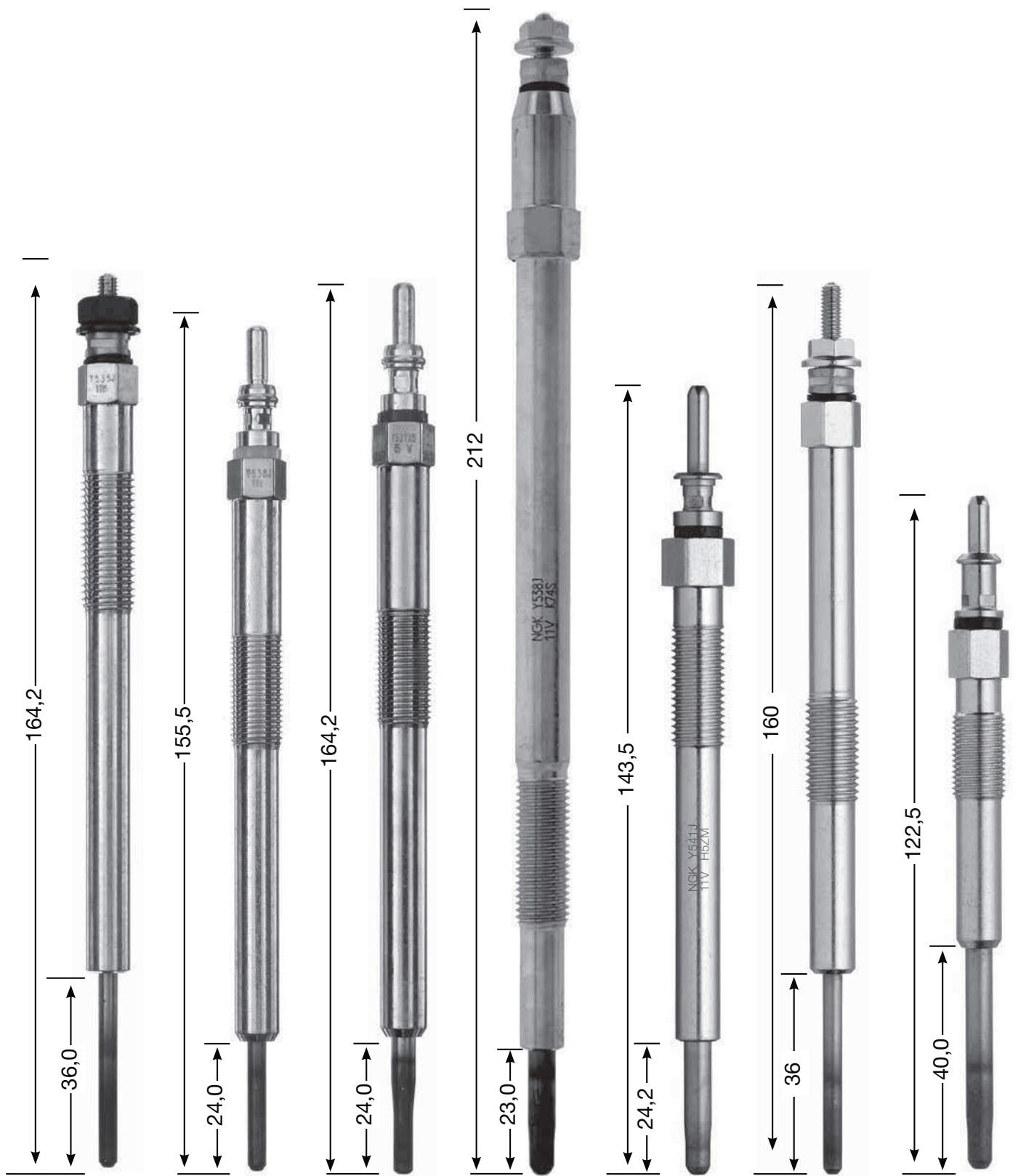

Y-535 J
 M 10 x 1.25
 10 Hex
 11 V

Y-536 J
 M 10 x 1.0
 10 Hex
 11 V
DP 81

Y-537 AS
 M 10 x 1.0
 10 Hex
 5 V

Y-538 J
 M 10 x 1.25
 12 Hex
 11 V

Y-541 J
 M 10 x 1.25
 12 Hex
 11 V
DP 42

Y-542 J
 M 10 x 1.25
 10 Hex
 11 V
DP 45

Y-543 J
 M 10 x 1.25
 10 Hex
 11 V
DP 46

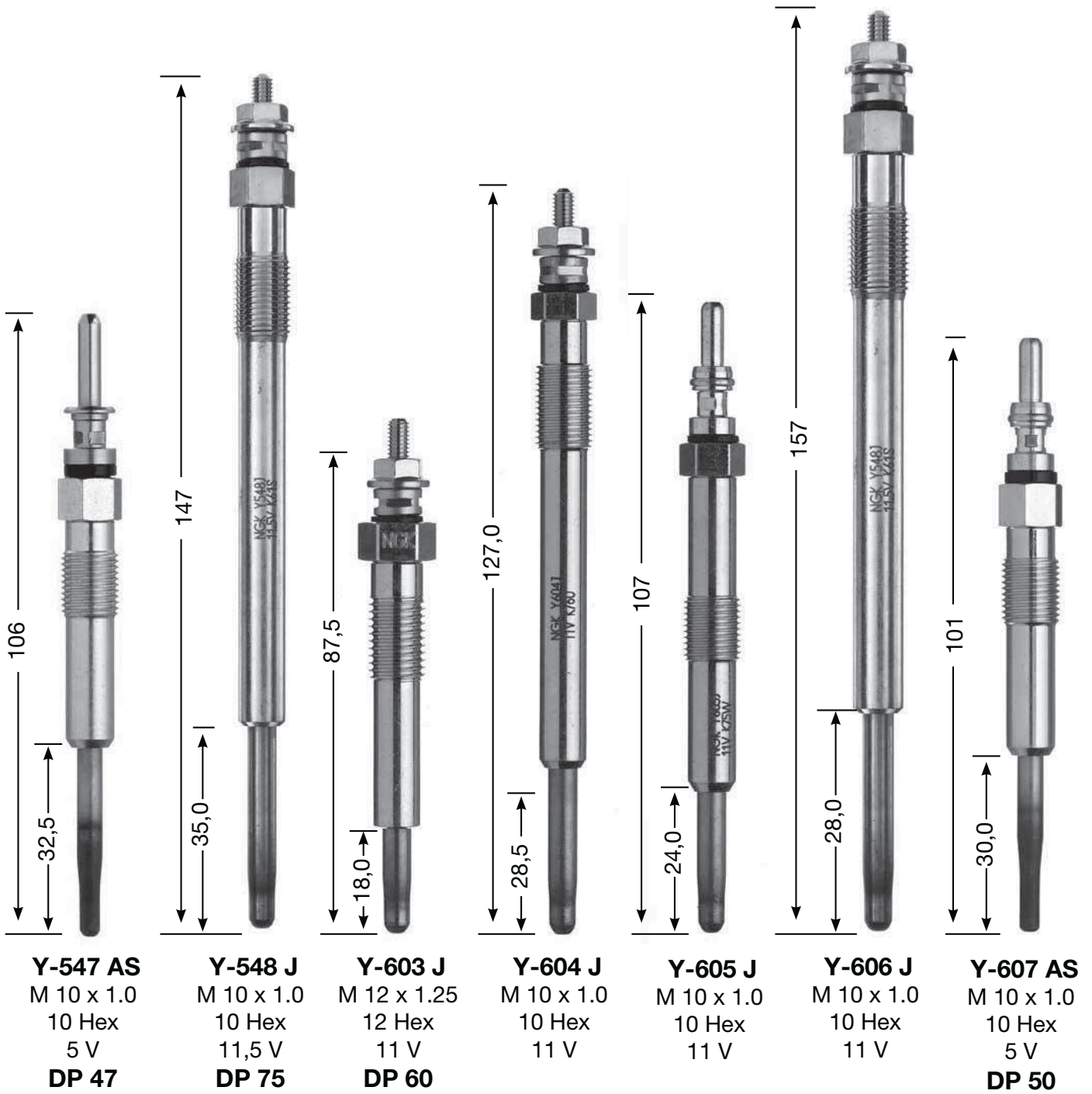

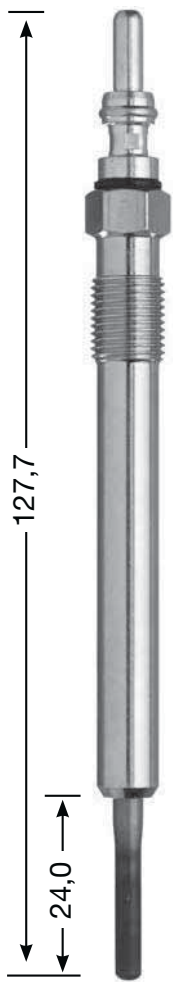

Y-609 AS
M 10 x 1.0
10 Hex
4,4 V
DP 49

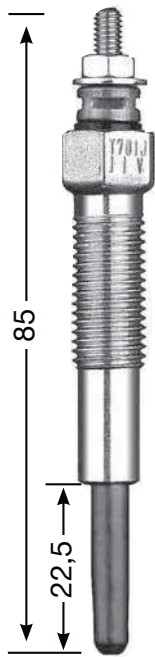

Y-701 J
M 10 x 1.25
12 Hex
11 V
DP 39

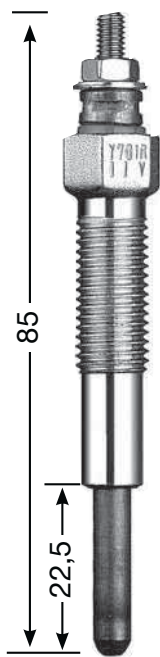

Y-701 R
M 10 x 1.25
12 Hex
11 V

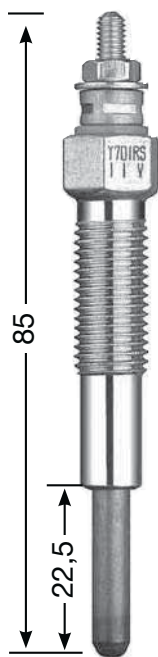

Y-701 RS
M 10 x 1.25
12 Hex
11 V



Y-701 U
M 10 x 1.25
12 Hex
10 V

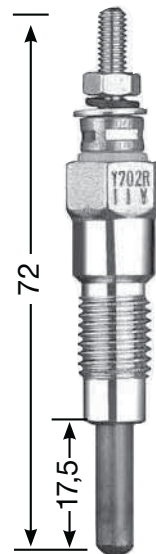

Y-702 R
M 10 x 1.25
12 Hex
11 V

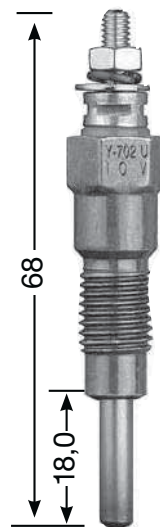

Y-702 U
M 10 x 1.25
12 Hex
10 V



Y-703 M1
M 10 x 1.25
12 Hex
11 V

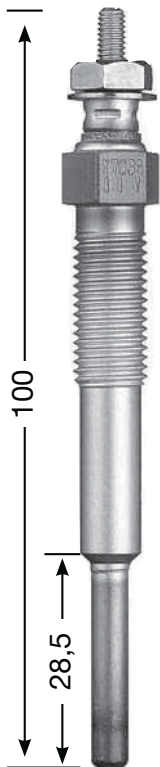

Y-703 R
M 10 x 1.25
12 Hex
11 V

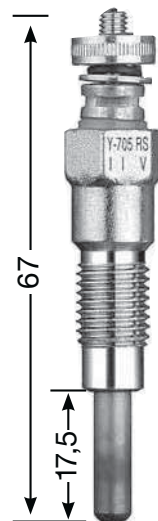

Y-705 RS
M 10 x 1.25
12 Hex
11 V

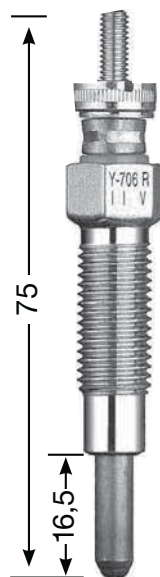

Y-706 R
M 10 x 1.25
12 Hex
11 V

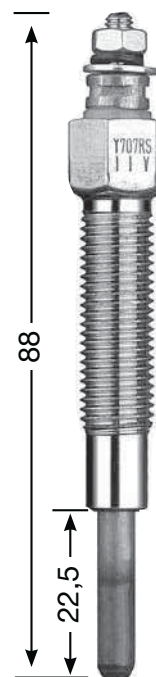

Y-707 RS
M 10 x 1.25
12 Hex
11 V

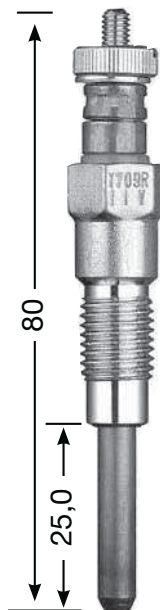

Y-709 R
M 10 x 1.25
12 Hex
11 V

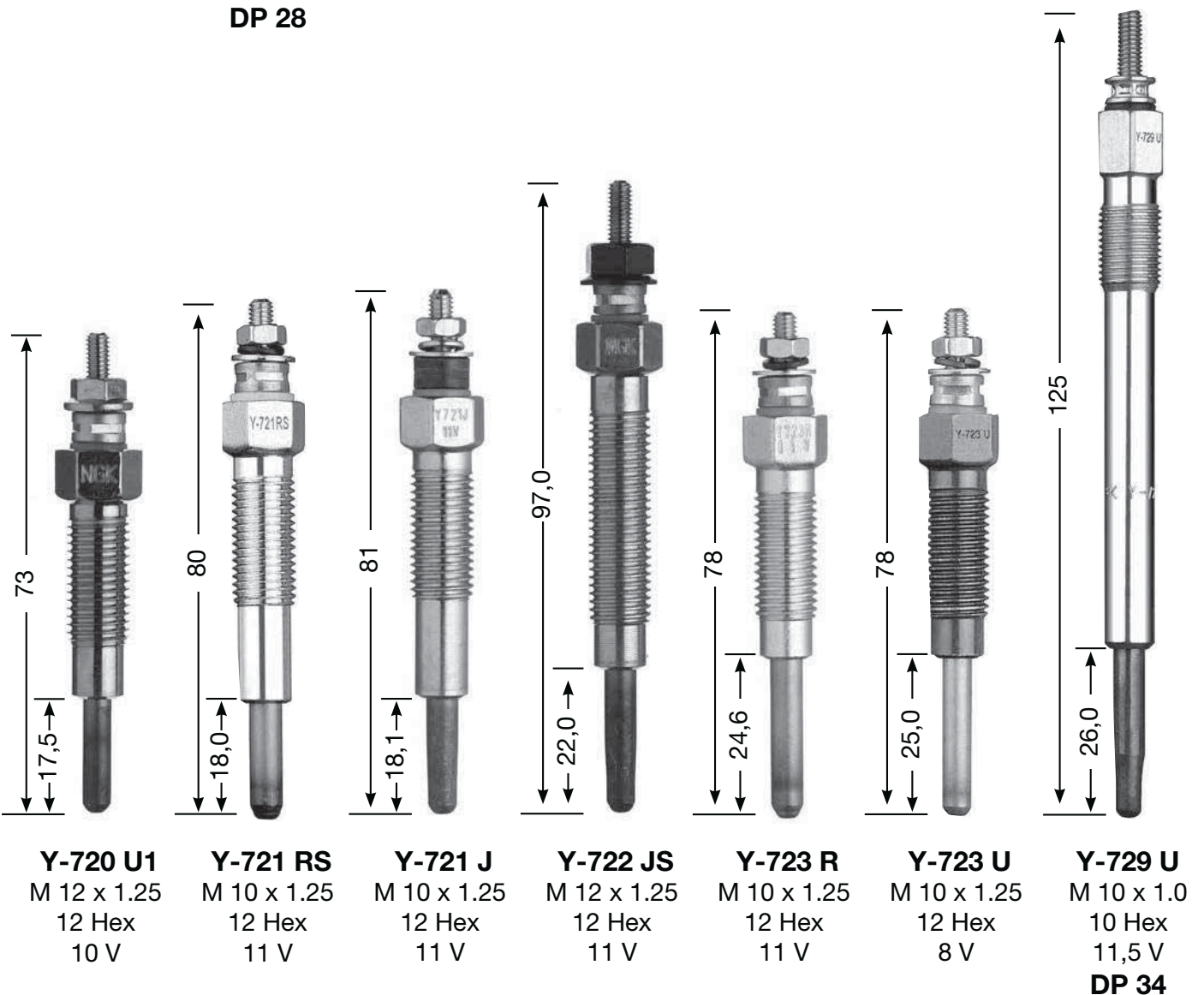
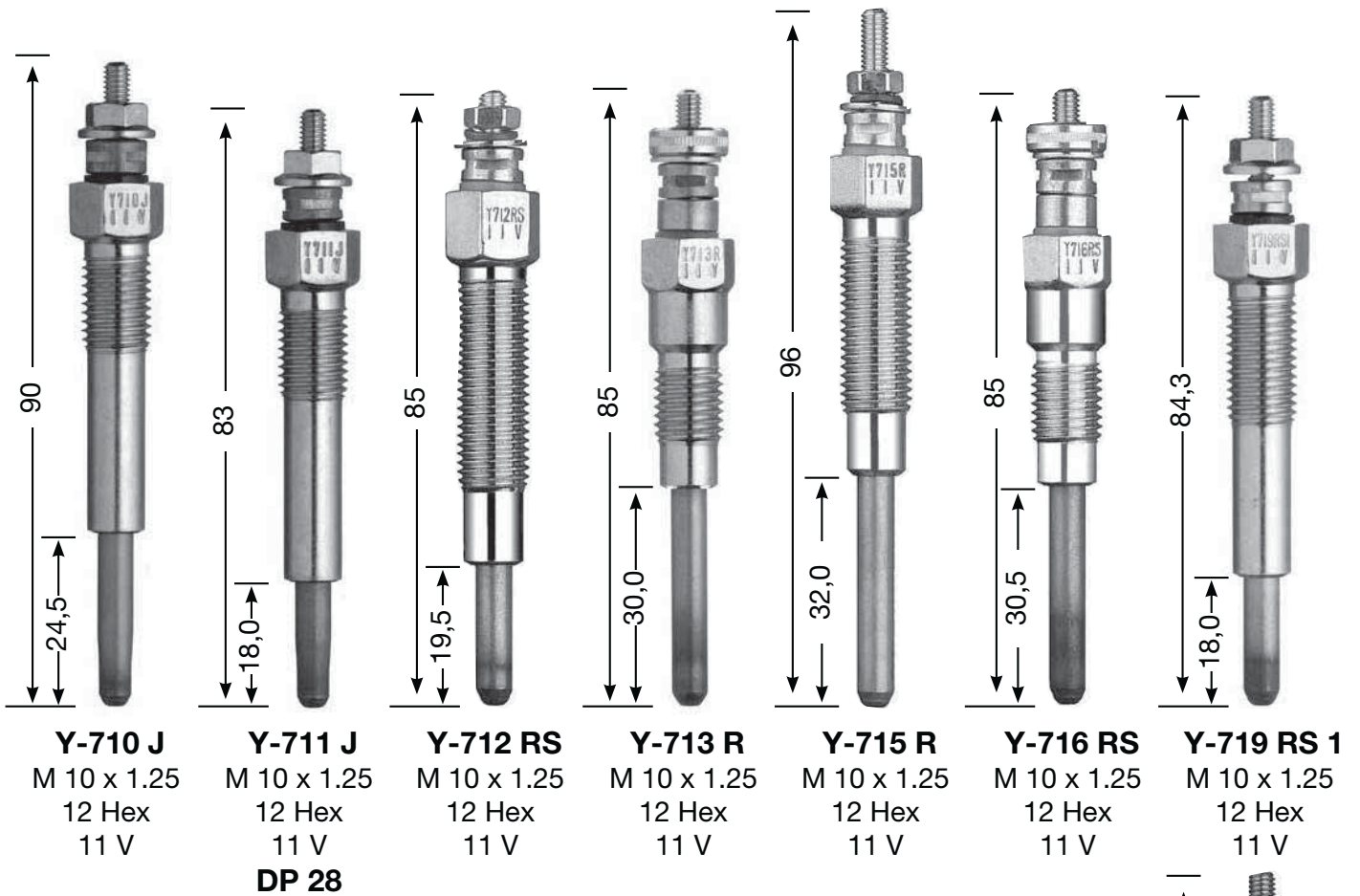

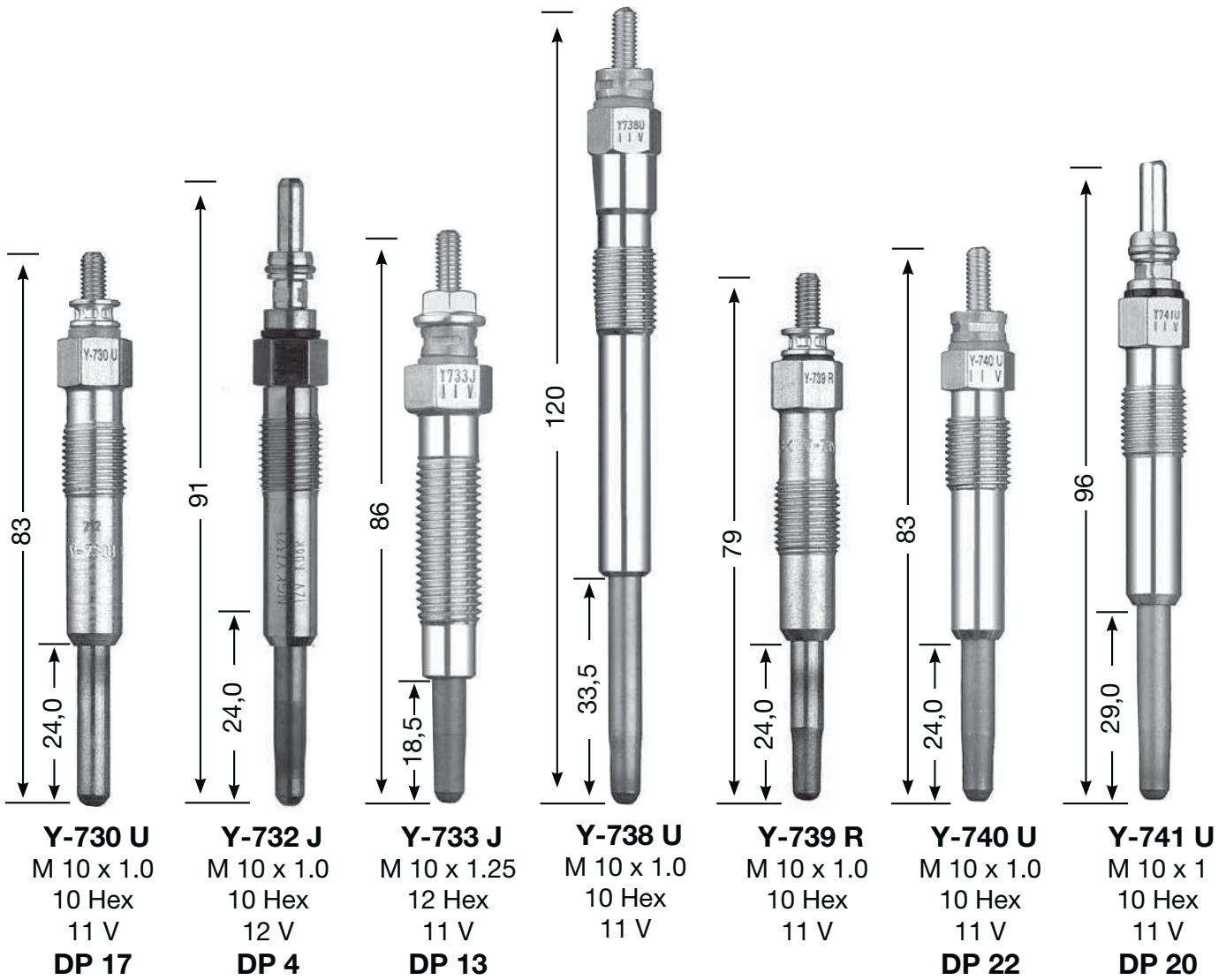

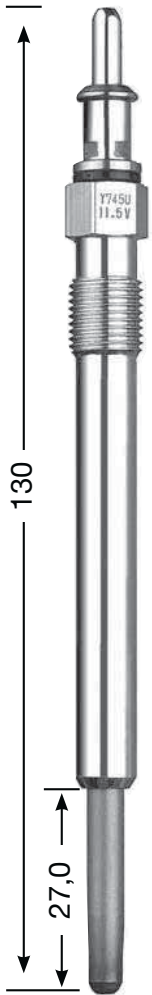

Y-745 U
M 10 x 1.0
10 Hex
11,5 V
DP 11

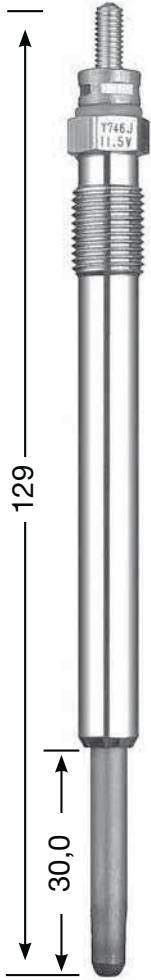

Y-746 J
M 10 x 1.0
10 Hex
11,5 V
DP 38

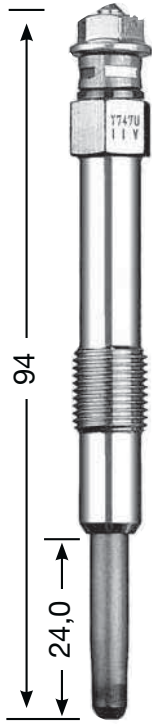

Y-747 U
M 10 x 1
10 Hex
11 V
DP 26

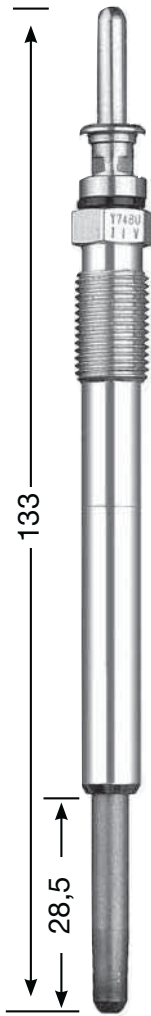

Y-748 U
M 10 x 1
10 Hex
11 V
DP 14



Y-749 J
M 10 x 1.0
10 Hex
11 V

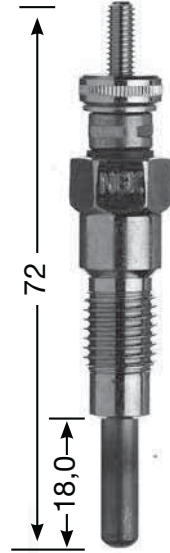

Y-752 M
M 12 x 1.25
12 Hex
23 V

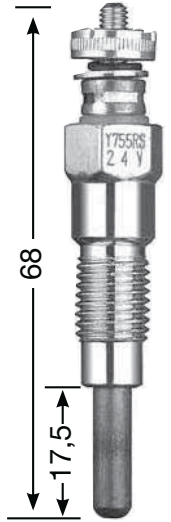

Y-755 RS
M 10 x 1.25
12 Hex
24 V

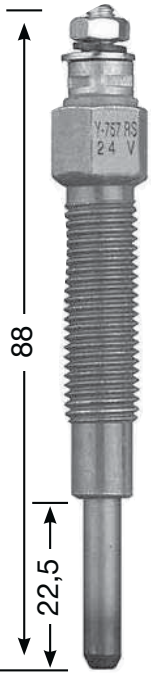

Y-757 RS
M 10 x 1.25
12 Hex
24 V

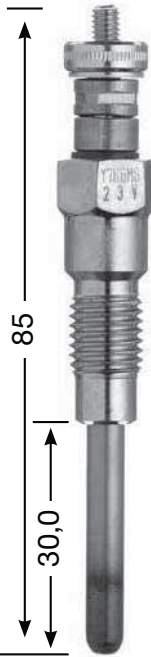

Y-766 MS
M 10 x 1.25
12 Hex
23 V

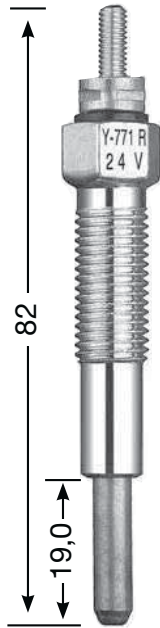

Y-771 R
M 10 x 1.25
12 Hex
24 V

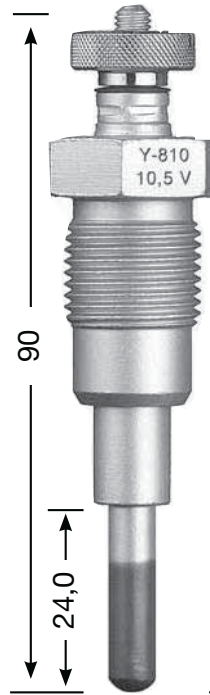

Y-810
M 18 x 1.5
20.6 Hex
10,5 V

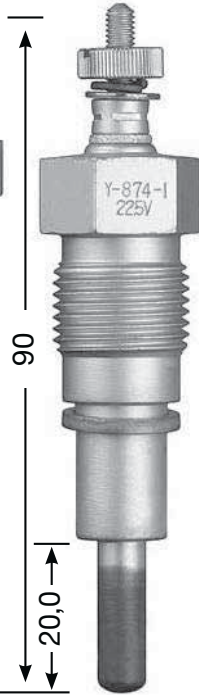

Y-874-1
M 18 x 1.5
19 Hex
22,5 V

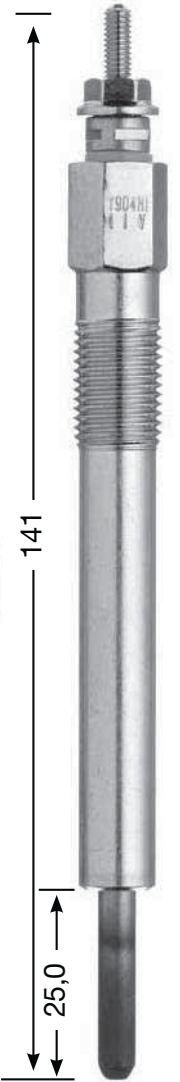

Y-904 M1
M 12 x 1.25
12 Hex
11 V

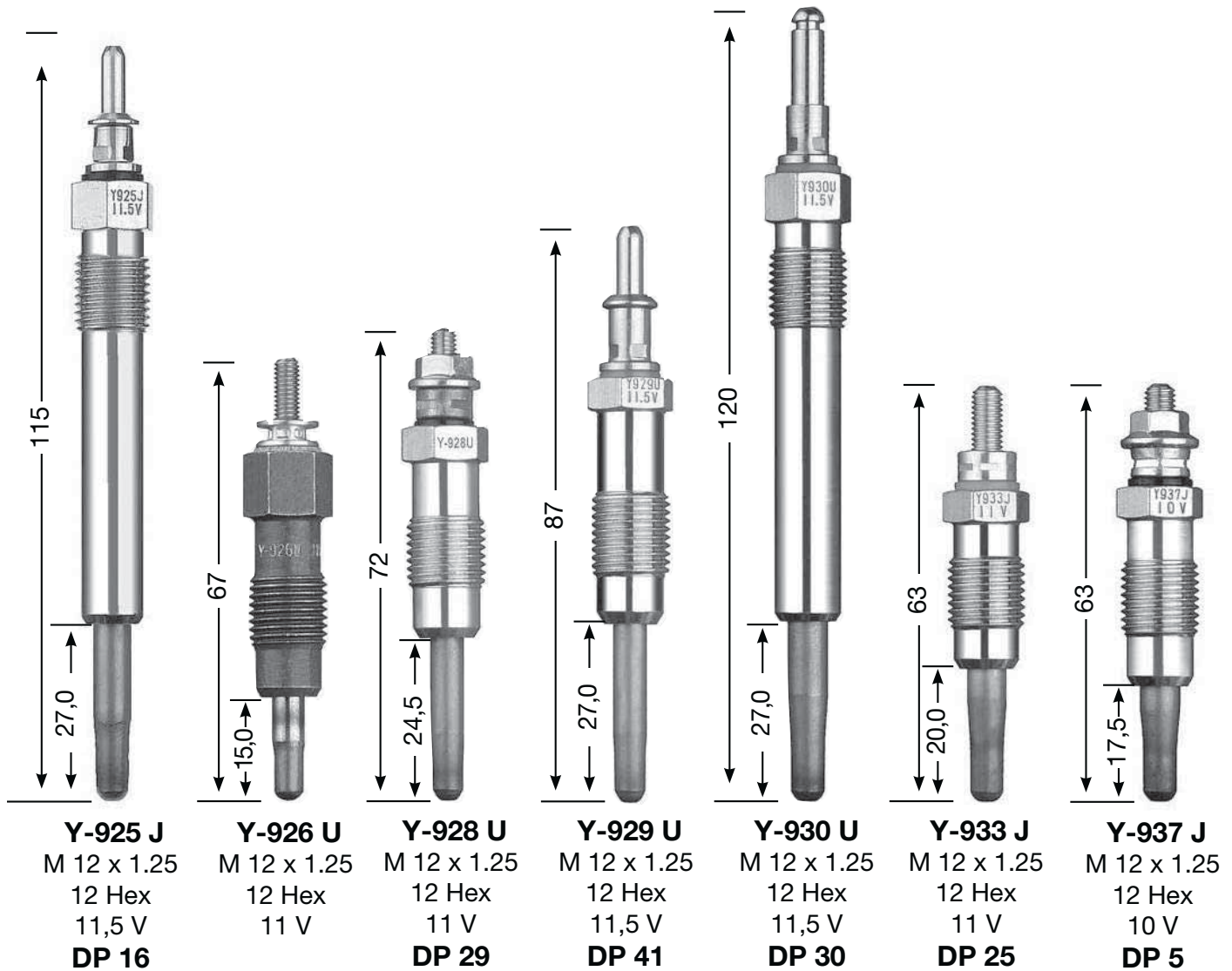
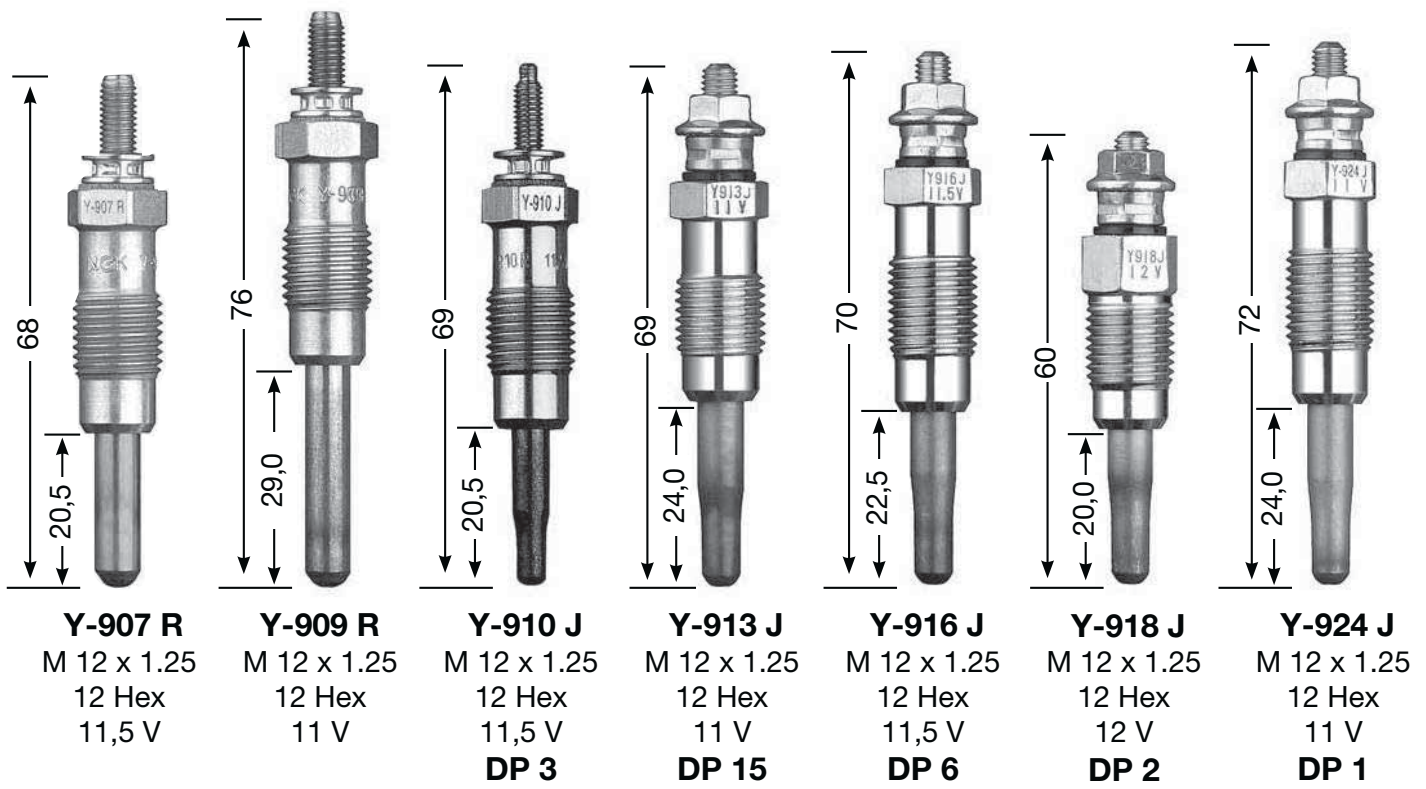



Y-939 J
 M 12 x 1.25
 12 Hex
 11 V
 DP 43

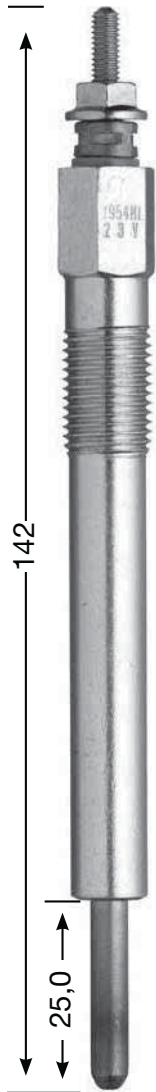

Y-954 M1
 M 12 x 1.25
 12 Hex
 23 V



Y-955 RS
 M 12 x 1.25
 14 Hex
 24 V

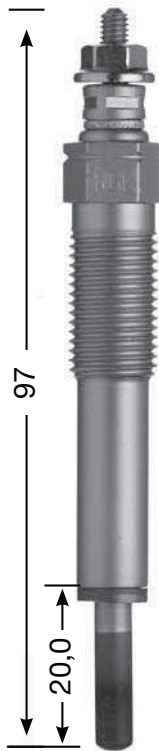

Y-971 M
 M 12 x 1.25
 12 Hex
 23 V



Y1001 J1
 M 10 x 1.25
 12 Hex
 11 V

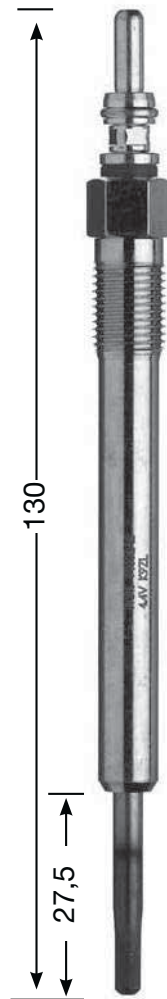

Y1002 AS
 M 10 x 1.0
 10 Hex
 4,4 V
 DP 57



Y1003 AS
 M 10 x 1.25
 10 Hex
 5 V



Y1005 J
 M 10 x 1.0
 10 Hex
 11 V
 DP 56

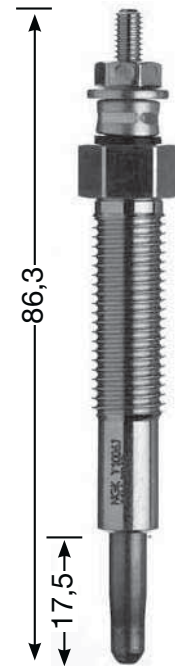

Y1006 J
 M 12 x 1.25
 12 Hex
 11 V

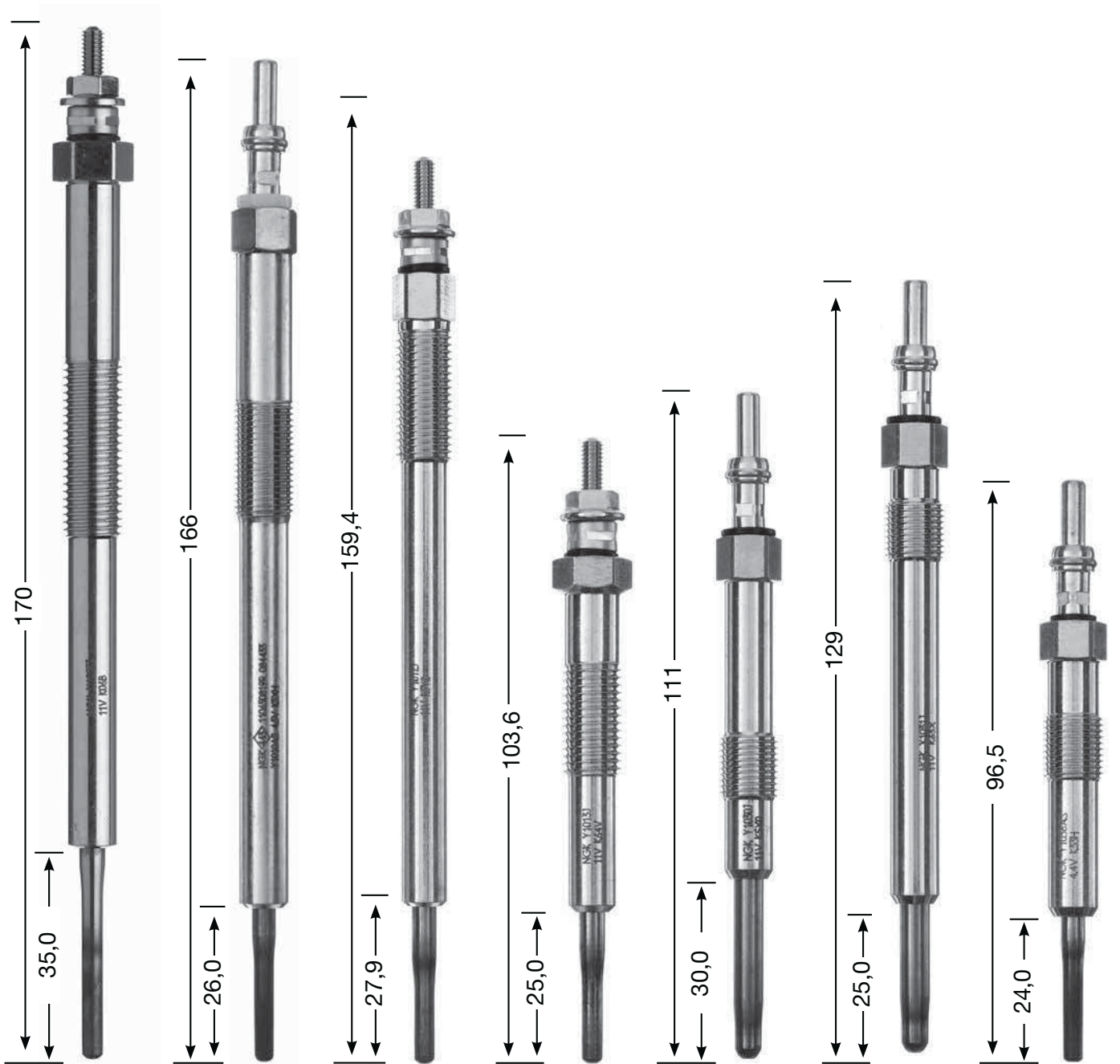

Y1007 J
 M 12 x 1.25
 12 Hex
 11 V
DP 59

Y1010 AS
 M 10 x 1.0
 10 Hex
 4,5 V
DP 88

Y1012 J
 M 10 x 1.25
 10 Hex
 11 V
DP 65

Y1013 J
 M 10 x 1.25
 10 Hex
 11 V
DP 63

Y1030 J
 M 10 x 1.0
 10 Hex
 11 V
DP 70

Y1031 J
 M 10 x 1.0
 10 Hex
 11 V
DP 71

Y1036 AS
 M 10 x 1.0
 10 Hex
 4,4 V

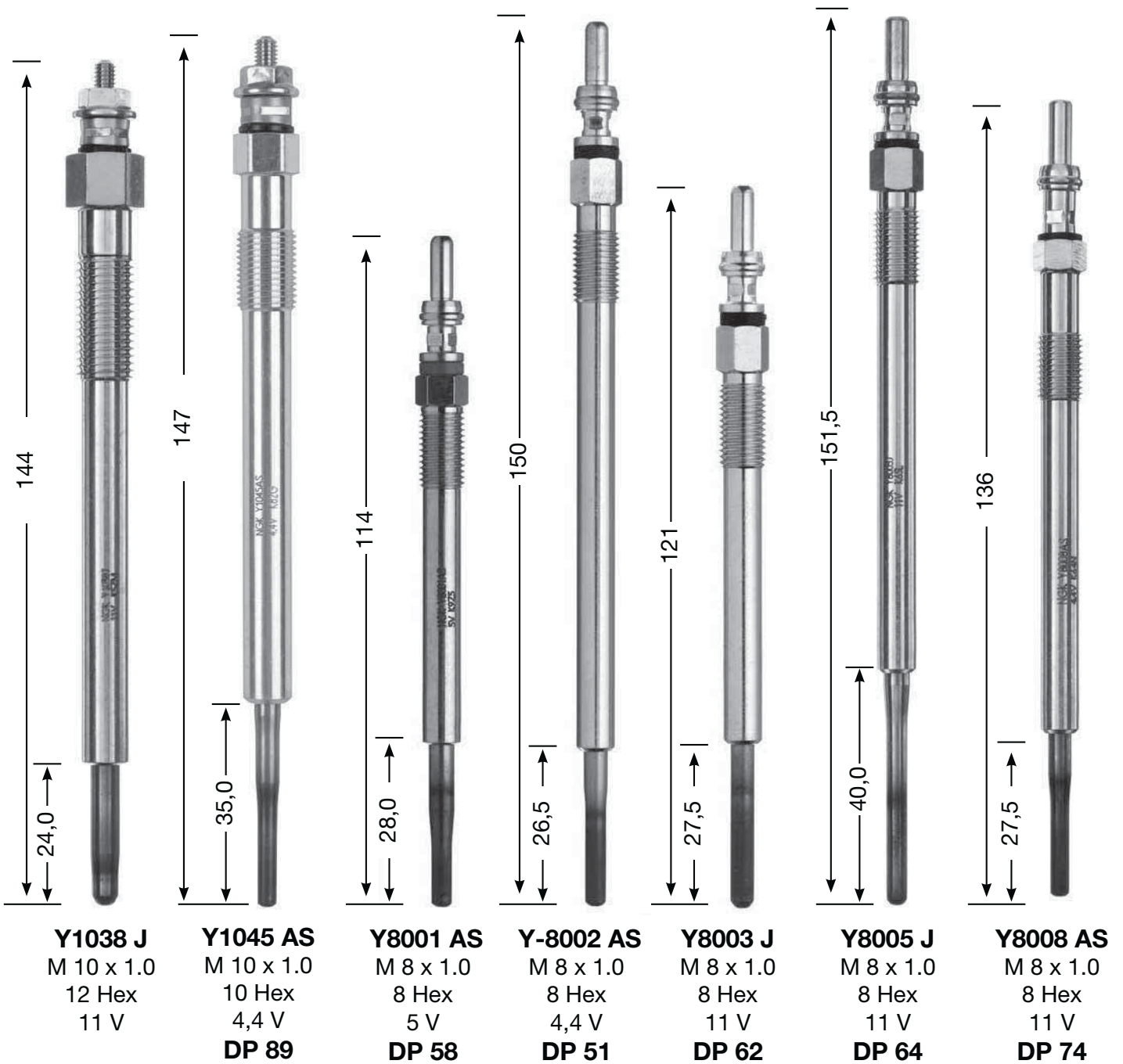

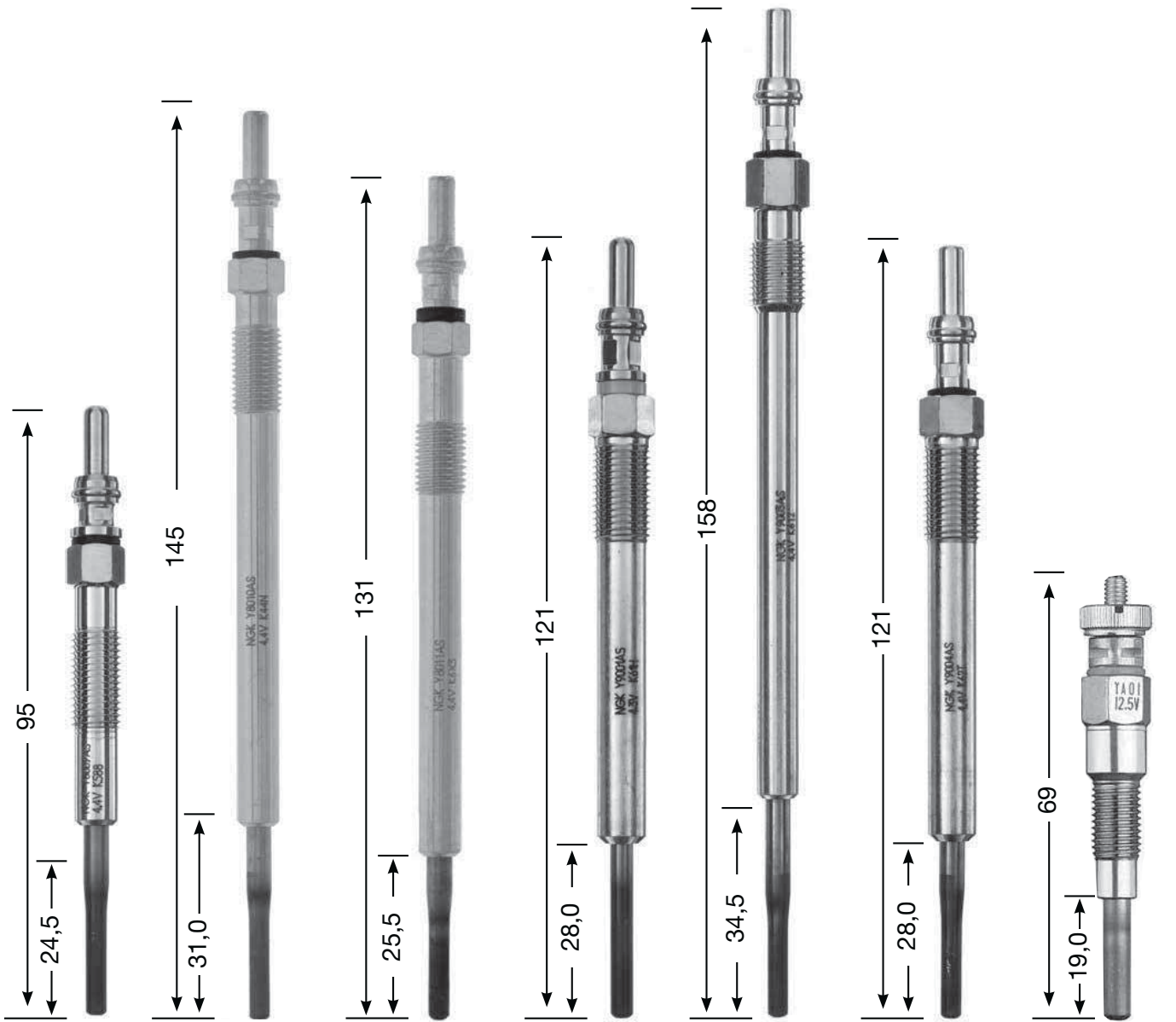

Y8009 AS
M 8 x 1.0
8 Hex
4,4 V

Y8010 AS
M 8 x 1.0
8 Hex
4,4 V

Y8011 AS
M 8 x 1.0
8 Hex
4,4 V

Y9001 AS
M 9 x 1.0
9 Hex
4,3 V
DP 72

Y9003 AS
M 9 x 1.0
9 Hex
4,4 V
DP 72

Y9004 AS
M 9 x 1.0
9 Hex
4,4 V
DP 72

YA 01
M 8 x 1.0
10 Hex
12,5 V

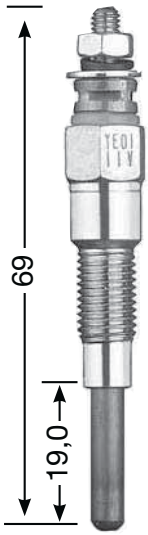

YE 01
M 8 x 1.0
10 Hex
11 V

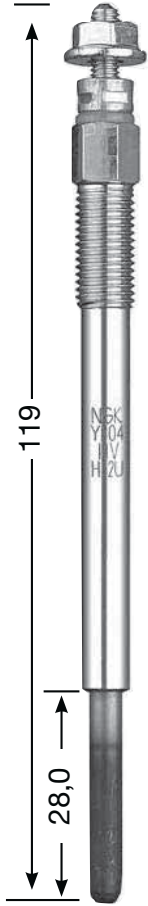

YE 04
M 8 x 1.0
8 Hex
11 V
DP 40

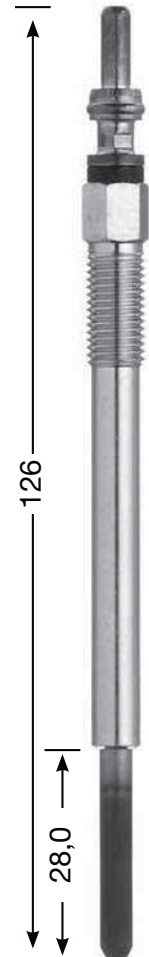

YE 05
M 8 x 1.0
8 Hex
11 V

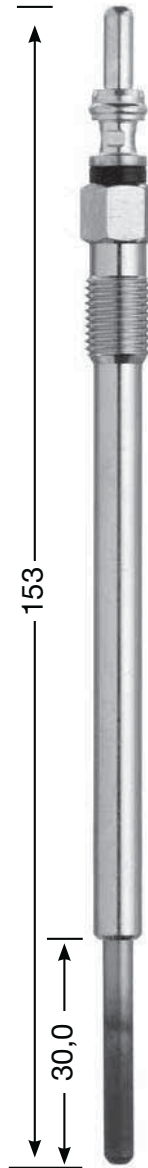

YE 07
M 9 x 1.0
9 Hex
11 V



YE 08
M 8 x 1.0
8 Hex
11 V

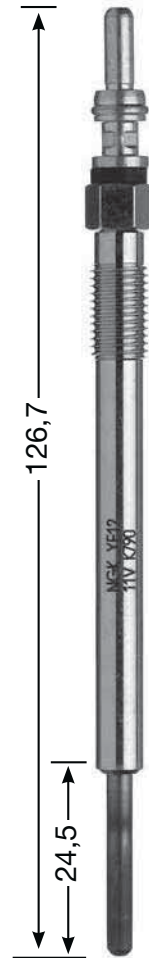

YE 12
M 8 x 1.0
8 Hex
11 V

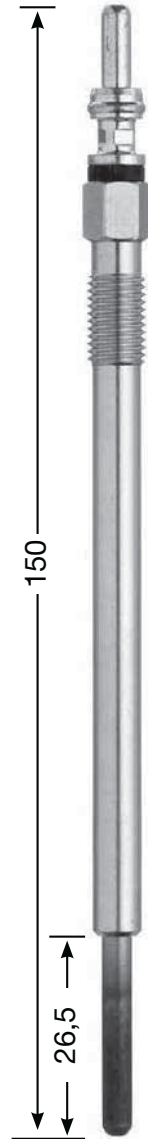

YE 13
M 8 x 1.0
8 Hex
11,5 V

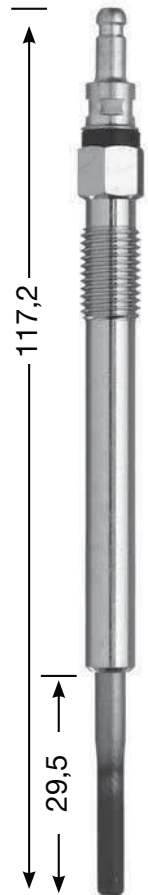

YE 14
M 8 x 1.0
8 Hex
4,4 V
DP 48

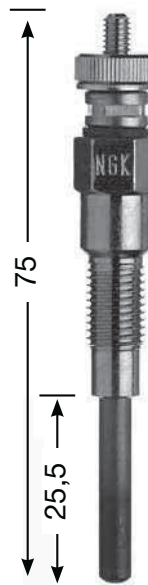

YE 52
M 10 x 1.0
10 Hex
23 V

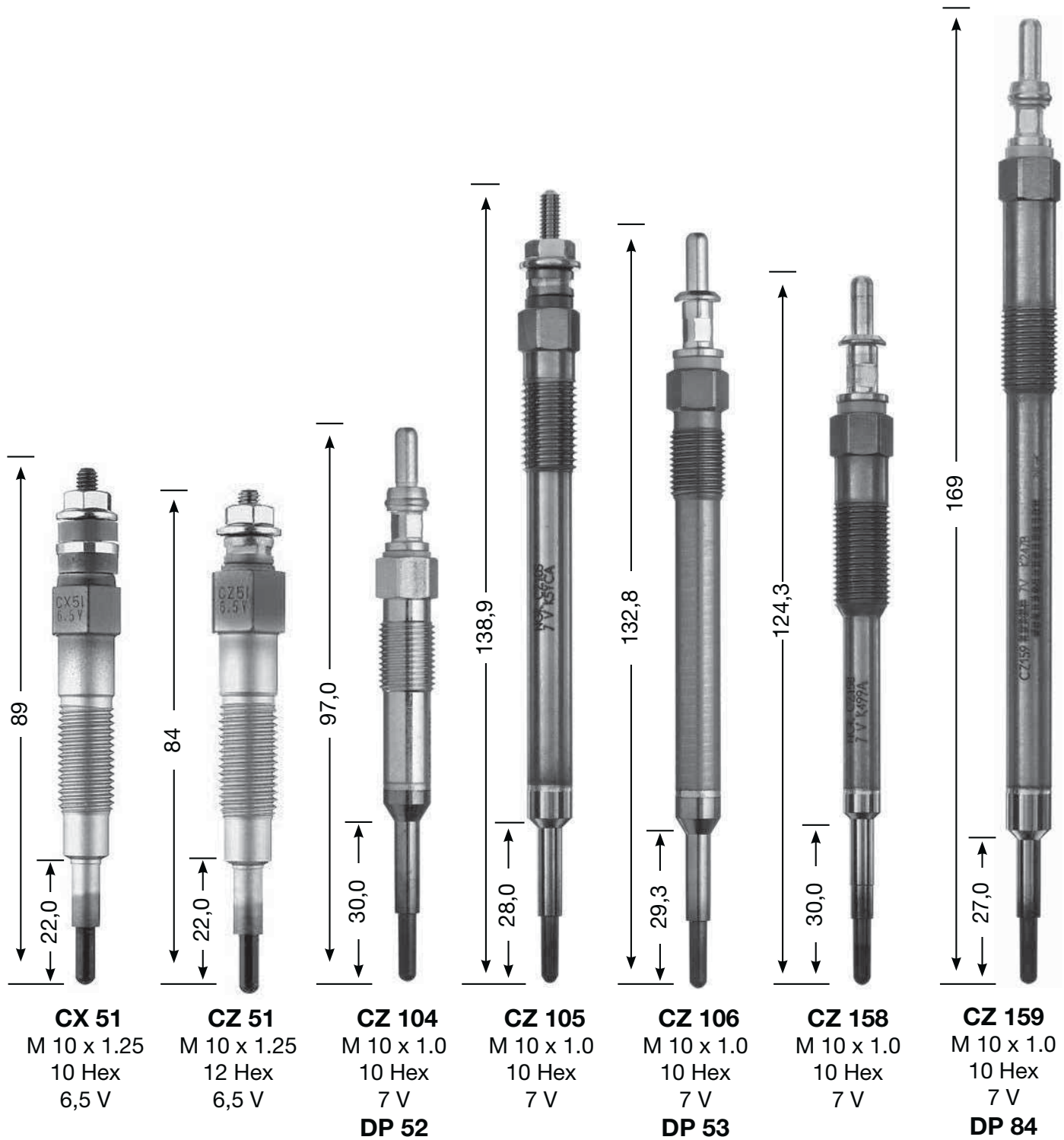

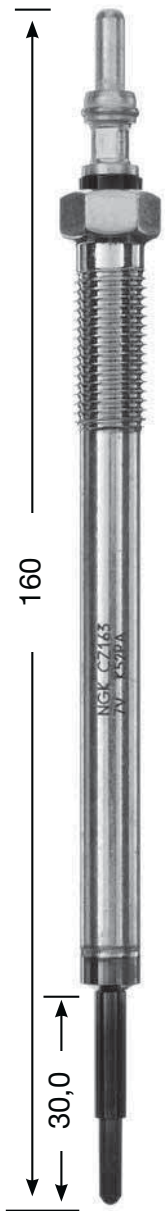

CZ 163
M 10 x 1.25
12 Hex
7 V
DP 82



CZ 165
M 10 x 1.25
10 Hex
7 V
DP 87



CZ 203
M 10 x 1.25
12 Hex
11 V
DP 68



CZ 251
M 10 x 1.25
12 Hex
11 V
DP 76



CZ 256
M 10 x 1.25
12 Hex
11 V



CZ 257
M 10 x 1.25
12 Hex
11 V
DP 83

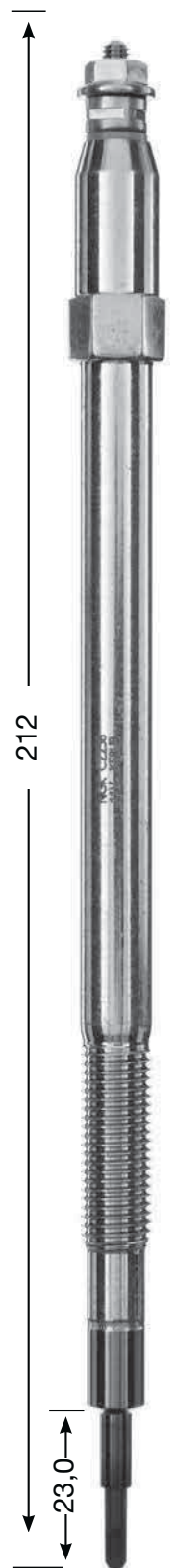

CZ 258
M 10 x 1.25
12 Hex
11 V

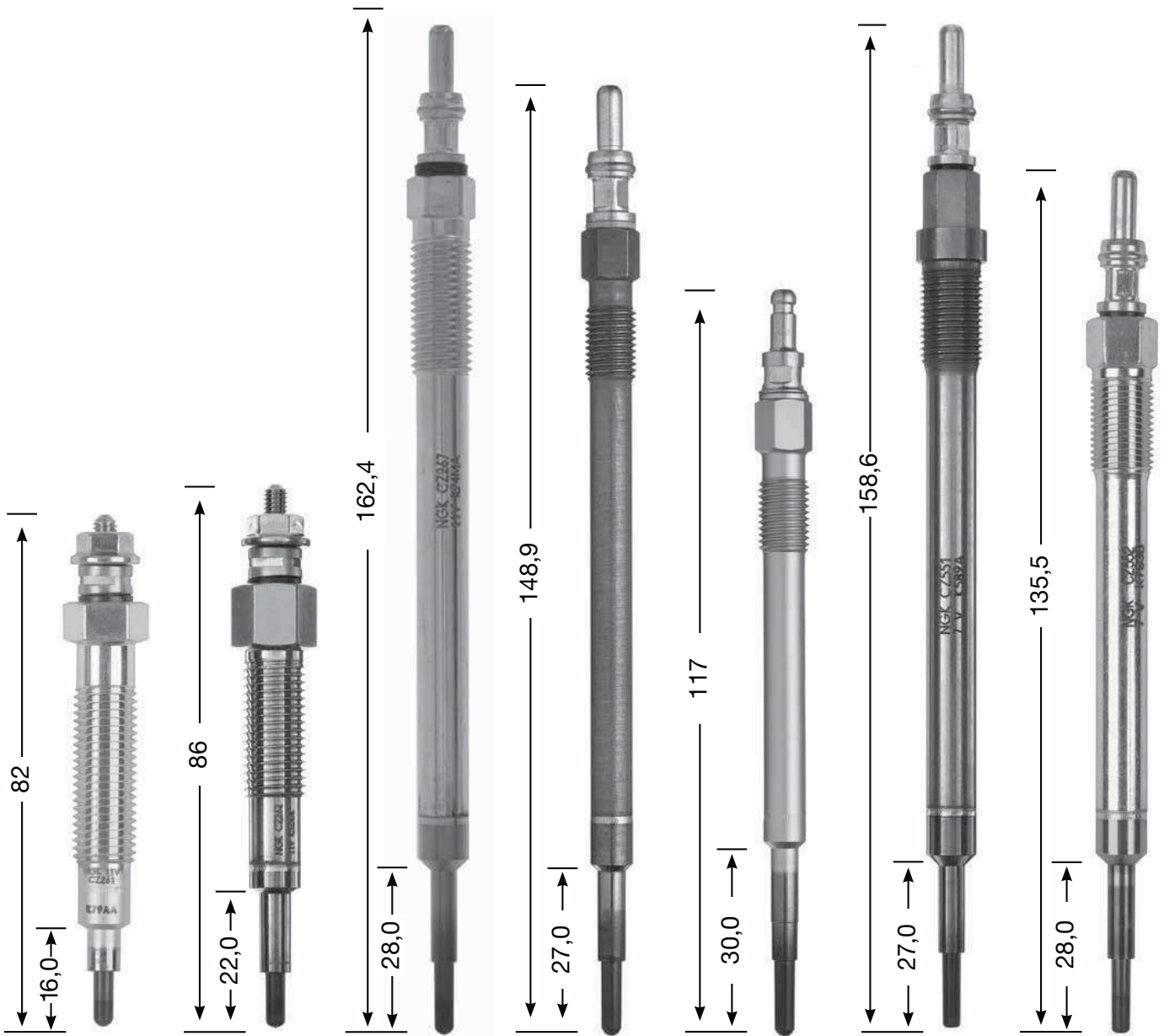

CZ 261
M 10 x 1.25
12 Hex
11 V

CZ 262
M 10 x 1.25
12 Hex
11 V
DP 13

CZ 267
M 10 x 1.25
10 Hex
11 V

CZ 303
M 8 x 1.0
8 Hex
7 V
DP 54

CZ 304
M 8 x 1.0
8 Hex
7 V
DP 55

CZ 551
M 10 x 1.0
8 Hex
7 V
DP 85

CZ 552
M 10 x 1.0
10 Hex
7 V
DP 68



250

250



IGNITION
PARTS





HP

c
mC
y
l

Stock-Nr

FRIDUM

Stock-NrX

AERO MARINE

AM 4000	4		1	1970-1973		0,9	BP5S	3011		
Jet Pak	4		1	1971-1973		0,9	BP5S	3011		
AM 5000 M	5			1970-1972		0,9	B-6L	3212		
AM 5000 E	5			1970-1972		0,9	B-6L	3212		
AM 7500M	7,5			1970-1973		0,9	BM6A	5921		
AM 7500E	7,5			1970-1973		0,9	BM6A	5921		
AM 9000	9			1971-1973		0,6	BM6A	5921		

AILS CRAIG

AL-23				-		0,6	AB-6	2910		
O-11				-		0,6	AB-6	2910		
O-21				-		0,6	AB-6	2910		
O-22				-		0,6	AB-6	2910		
O-41				-		0,6	AB-6	2910		
O-411				-		0,6	AB-6	2910		

AIRBOY

20				-		0,8	B6S	3510		
40				-		0,8	B6S	3510		
90				-		0,8	B6S	3510		
50				-		0,8	B6S	3510		
90				-		0,8	AP5FS	2610		
120				-		0,8	B-6L	3212		

ALDENS (Pathfinder)

All Models		1235		1961-1967		0,8	BR6S	3522		
Model 1186	5,7			1970-1971		0,9	BP5S	3011		
All Model (Except 1186)	5,7			1968-1969		0,9	BR6S	3522		
Model 1186	7			1969-		0,9	BP5S	3011		

APACHE

J 5				-		0,8	BR6S	3522		
J 9				-		0,8	BR6S	3522		

AQUABUG

Aquabug 120	1,2	120	1	-		0,8	BP5S	3011		
Superbug 175	1,7	175	1	-		0,8	BP5S	3011		
Superbug 300	3	300	1	-		0,8	BP5S	3011		

ARKOS

Aquascooter				-		0,5	B6HS	4510	BR6HIX	3419
-------------	--	--	--	---	--	-----	------	------	--------	------

BOATIMPELLER

All Models				-		0,5	AB-6	2910		
------------	--	--	--	---	--	-----	------	------	--	--



HP

c
mC
Y
I

Stock-No

FRIDIUM

Stock-NrX

BOMBARDIER

Speedster 20				-		0,7	DCPR8E	4339	DCPR8EIX	6546
Sportster 4-TEC			3	2004-2004		0,7	DCPR8E	4339	DCPR8EIX	6546
Sportster LE-Di			2	2004-2006		1,1	ZFR4F-11	4043		

BRITISH ANZANI

Pilot 2				-		0,6	B6HS	4510	BR6HIX	3419
Pilot 3				-		0,6	B6HS	4510	BR6HIX	3419
Pilot 4				-		0,6	B6HS	4510	BR6HIX	3419
Minor Seamaid				-		0,6	B6HS	4510	BR6HIX	3419
Minor Seamaid				-		0,6	B5HS	4210		
Seasprite				-		0,6	B6HS	4510	BR6HIX	3419
Super Snipe				-		0,6	AB-6	2910		
Pilot 1	1,5	60	1	-		0,6	B6HS	4510	BR6HIX	3419
Pilot 30	3			-		0,6	B6HS	4510	BR6HIX	3419
Jet 3	3	60	1	-		0,6	B6HS	4510	BR6HIX	3419
Jet 3	3	60	1	-		0,6	B5HS	4210		
Super Single	5	158	1	1942-1979		0,6	AB-6	2910		
65	6,5			1964-1967		0,7	B6S	3510		
Unitwin	10	242		1951-1967		0,6	B6HS	4510	BR6HIX	3419
Supertwin	15	322	2	-		0,6	B6HS	4510	BR6HIX	3419
Unitwin	15	322		1951-1967		0,6	B6HS	4510	BR6HIX	3419
180	18			1964-1967		0,7	B-6L	3212		
Magnatwin	18	344	2	1958-1960		0,6	B6HS	4510	BR6HIX	3419
Fleetwin	20	344	2	-		0,6	B6HS	4510	BR6HIX	3419
Triton	30	492	3	1960-		0,6	B6ES	7310		
400	40			1964-1967		0,6	B6HS	4510	BR6HIX	3419

BRITISH SEAGULL

Minor BM				-		0,5	B6HS	4510	BR6HIX	3419
Forty Minus	1,5	64	1	1955-1967		0,5	AB-6	2910		
Featherweight	2	64	1	-		0,5	AB-6	2910		
Forty Plus	3	64	1	- 1980	CD Ignition	0,5	AB-6	2910		
Forty Plus	3	64	1	- 1980	Magneto Ignition	0,5	AB-6	2910		
Century	4	102	1	1967-1973		0,5	AB-6	2910		
QB Curlew	4	102	1	1987-1990		0,8	B7ES	1111	BR7EIX	6664
Silver Century	4,5	102	1	1978-1990		0,5	AB-6	2910		
Century Plus	5	102	1	1967-1973		0,5	AB-6	2910		
QB Osprey	5	102	1	1987-1990		0,8	B7ES	1111	BR7EIX	6664
Silver Century Plus	5	102	1	1979-1991		0,5	AB-6	2910		
QB Kingfisher	6	102	1	1987-1990		0,8	B7ES	1111	BR7EIX	6664
SD160	10	102	1	-		0,8	B7ES	1111	BR7EIX	6664

CAL-JET

Econojet				-		0,8	B6S	3510		
Ramjet				-		0,8	B6S	3510		



HP

c
c
mC
y
l

Stock-Nr

FRIBUM

Stock-NrX

CARNITI

18/ 280CN/ 45/ 55/ 65/ 80				-		0,5	B8HS	5510	BR8HIX	7001
45S				-		0,8	B9HS	5810	BR9HIX	5687
65S				-		0,8	B9HS	5810	BR9HIX	5687
80S				-		0,8	B9HS	5810	BR9HIX	5687
700 Sport				-		0,5	B8HS	5510	BR8HIX	7001
850 Sport				-		0,5	B8HS	5510	BR8HIX	7001
1000 Sport				-		0,5	B8HS	5510	BR8HIX	7001

CHIEF

J-5				-		0,8	BM6A	5921		
K-150	1,5			-		0,8	BM6A	5921		
J-200	2			-		0,8	BM6A	5921		
K-200	2			-		0,8	BM6A	5921		
K-201	2			1976-1978		0,6	BP5S	3011		
J-300	3			-		0,8	BM6A	5921		
K-300	3			-		0,8	BM6A	5921		
J-350	3,5			-		0,8	BM6A	5921		
K-350	3,5			1976-1978		0,6	BM6A	5921		
J-400	4			-		0,8	BM6A	5921		
K-400	4			-		0,8	BM6A	5921		
J-500	5			-		0,8	BM6A	5921		
J-9	5			-		0,8	BP5S	3011		
K-500	5			1973-		0,8	BM6A	5921		
K-500	5			1974-1975		0,8	BP5S	3011		
K-505	5,5			1976-1978		0,6	BP5S	3011		
K-550	5,5			1976-1978		0,6	BP5S	3011		
J-700	7			-		0,8	BM6A	5921		
K-700	7			1973-		0,8	BM6A	5921		
K-700	7			1974-1975		0,8	BP5S	3011		
K-750	7,5			1973-		0,8	BM6A	5921		
K-750	7,5			1974-1975		0,8	BP5S	3011		
K-751	7,5			1976-1978		0,6	BP5S	3011		
K-753	7,5			1976-1978		0,6	BP5S	3011		
K-900	9			1976-1978		0,6	BP5S	3011		
K-990	9,9			-		0,8	BM6A	5921		

CHRIS-CRAFT

Challenger	5,5			-		0,7	B6S	3510		
Commander	10			-		0,7	B6S	3510		

CHRYSLER

Sailor 150	6		2	1980-		0,8	B6HS	4510	BR6HIX	3419
Sailor 180	7,5		2	1981-1984		0,8	B6HS	4510	BR6HIX	3419
Sailor 190	7,5		2	1979-		0,8	B6HS	4510	BR6HIX	3419
Sailor 250	9,9	216	2	1979-1984		0,8	B6HS	4510	BR6HIX	3419
Sailor 300	12		2	1979-		0,8	B6HS	4510	BR6HIX	3419
Magneto	45		2	1971-1978		-	BUHX	2522		
Magneto	55		2	1969-1980		-	BUHX	2522		



HP

c
m
C
y
l

Stock-Nº

FRIDUM

Stock-NºX

CLINTON

K-150	1,5		-		0,8	BM4A	5628		
K-150	1,5		1976-1979		0,6	BR6S	3522		
J-200	2		-		0,8	BM4A	5628		
K-200	2		-		0,8	BM4A	5628		
K-201	2		1976-1991		0,6	BR6S	3522		
J-300	3		-		0,8	BM4A	5628		
K-300	3		-		0,8	BM4A	5628		
J-350	3,5		-		0,8	BM4A	5628		
K-350	3,5		1976-1987		0,6	BM4A	5628		
J-400	4		-		0,8	BM4A	5628		
K-400	4		-		0,8	BM4A	5628		
AJ-9	5		-		0,8	BM4A	5628		
BJ-9	5		-		0,8	BM4A	5628		
J-5	5		-		0,8	BM4A	5628		
J-9	5		-		0,8	BR6S	3522		
J-500	5		-		0,8	BM4A	5628		
K-500	5		1973-1973		0,8	BM4A	5628		
K-500	5		1974-1975		0,8	XR5	3332	XR5IX	7355
K-505	5		1976-1991		0,6	XR5	3332	XR5IX	7355
K-550	5,5		1976-1991		0,6	XR5	3332	XR5IX	7355
J-700	7		-		0,8	BM4A	5628		
K-700	7		1973-		0,8	BM4A	5628		
K-700	7		1974-1975		0,8	XR5	3332	XR5IX	7355
K-750	7,5		1973-		0,8	BM4A	5628		
K-750	7,5		1974-1984		0,8	XR5	3332	XR5IX	7355
K-751	7,5		1976-1991		0,6	XR5	3332	XR5IX	7355
K-753	7,5		1976-1991		0,6	XR5	3332	XR5IX	7355
K-900	9		1976-1991		0,6	XR5	3332	XR5IX	7355
K-990	9,9		-		0,8	BM4A	5628		
W-100	10		-		0,6	BR6HS	3922	BR6HIX	3419
W-140	14		-		0,6	BR6HS	3922	BR6HIX	3419
W-250	25		-		0,6	BR6HS	3922	BR6HIX	3419

COV. CLIMAX

FWA Mk.III PPF			-		0,6	B8ES	2411	BR8EIX	5044
FWM		750	-		0,6	B6ES	7310		

DM

DM 5		219	-		0,8	B5HS	4210		
100			-		0,5	B6HS	4510	BR6HIX	3419
150			-		0,5	B6HS	4510	BR6HIX	3419
200			-		0,5	B6HS	4510	BR6HIX	3419
Bambi 30			-		0,6	B6HS	4510	BR6HIX	3419
Cucciolo 5	5		-		0,5	B6HS	4510	BR6HIX	3419
Cucciolo 10	10		-		0,5	B6HS	4510	BR6HIX	3419
Cucciolo 15	15		-		0,5	B6HS	4510	BR6HIX	3419
Cucciolo 20	20		-		0,5	B6HS	4510	BR6HIX	3419



HP

c
c
mC
y
l

Stock-Nº

FRIDUM

Stock-NºX

ELGIN

6091	3,5			-		0,8	BM4A	5628		
6092	3,5			-		0,8	BM4A	5628		
60900	3,5			-		0,8	BM4A	5628		
6066	9			-		0,8	BM4A	5628		
6067	9			-		0,8	BM4A	5628		
6012	12			-		1,0	BR6S	3522		
6013	14			-		1,0	BR6S	3522		
6014	14			-		1,0	BR6S	3522		
6015	14			-		1,0	BR6S	3522		
6069	14			-		1,0	BR6S	3522		
59661	18			-		1,0	BR6S	3522		
59671	18			-		1,0	BR6S	3522		
6025	25			-		1,0	BR6S	3522		
6028	25			-		1,0	BR6S	3522		
6032	25			-		1,0	BR6S	3522		
26033	27,7			-		1,0	BR6S	3522		
6035	27,7			-		1,0	BR6S	3522		
6034	28			-		1,0	BR6S	3522		
6036	28			-		1,0	BR6S	3522		
6037	28			-		1,0	BR6S	3522		
6038	28			-		1,0	BR6S	3522		
6070	28			-		1,0	BR6S	3522		
6040	40			-		1,0	BR6S	3522		
6043	40			-		1,0	BR6S	3522		
6047	40			-		1,0	BR6S	3522		
59421	40			-		1,0	BR6S	3522		
59461	40			-		1,0	BR6S	3522		
59471	40			-		1,0	BR6S	3522		
594001	40			-		1,0	BR6S	3522		
594011	40			-		1,0	BR6S	3522		
594031	40			-		1,0	BR6S	3522		
6052	43,7			-		1,0	BR6S	3522		
6053	43,7			-		1,0	BR6S	3522		
6054	45			-		1,0	BR6S	3522		
6055	45			-		1,0	BR6S	3522		
6056	45			-		1,0	BR6S	3522		
6057	45			-		1,0	BR6S	3522		
6062	45			-		1,0	BR6S	3522		
6063	45			-		1,0	BR6S	3522		
6060	60			-		1,0	BR6S	3522		
6061	60			-		1,0	BR6S	3522		
6062	60			-		1,0	BR6S	3522		
6063	60			-		1,0	BR6S	3522		
6064	75			-		1,0	BR6S	3522		
6065	75			-		1,0	BR6S	3522		
6074	75			-		1,0	BR6S	3522		
6075	75			-		1,0	BR6S	3522		
6076	75			-		1,0	BR6S	3522		
6077	75			-		1,0	BR6S	3522		
6072	75,2			-		1,0	BR6S	3522		
6073	75,2			-		1,0	BR6S	3522		



HP

c
m
C
y
l

Stock-No

FRIBUM

Stock-NrX

EMERALD BAY

Banshee XS	50		1996-		0,9	B8ES	2411	BR8EIX	5044
Banshee XS	80		1996-		0,9	B8ES	2411	BR8EIX	5044

ESKA

1707	1,2		1 1970-1974		0,8	XR5	3332	XR5IX	7355
1747	1,2		1 1970-1974		0,8	XR5	3332	XR5IX	7355
1777	1,2		1 1970-1974		0,8	XR5	3332	XR5IX	7355
1790	1,2		1 1970-1974		0,8	XR5	3332	XR5IX	7355

EVINRUDE

Air Bouy Diving Unit			1966-1970		0,6	BM4A	5628		
1R	1		1 1968-1970		0,8	B6S	3510		
Magneto	1,2		1 1986-1990		0,8	B6S	3510		
SC	1,5		1968-1968		0,8	B6S	3510		
Aquanaut Diving Unit	2		1 1966-1970		0,8	BM4A	5628		
2R	2		1 1971-1984		0,8	B6S	3510		
Jr., Colt	2		1 1971-1990		0,8	B6S	3510		
Commercial	2		1 2000-2001		0,8	BZ7HS-10	3579		
Lightwin	3		2 1952-1974		0,8	B6S	3510		
JW	3		1952-1968		0,8	B6S	3510		
JH	3		1954-1968		0,8	B6S	3510		
JHF	3		1967-1968		0,8	B6S	3510		
JWF	3		1967-1968		0,8	B6S	3510		
Yachtwin	3,4		2 1964-1974		0,8	B6S	3510		
V4	4		1958-1967		0,8	B6S	3510		
V4A	4		1958-1967		0,8	B6S	3510		
V4M	4		1958-1967		0,8	B6S	3510		
V4S	4		1958-1967		0,8	B6S	3510		
VX	4		1958-1967		0,8	B6S	3510		
VXH	4		1958-1967		0,8	B6S	3510		
Yachtwin	4		2 1964-1974		0,8	B6S	3510		
4R	4		1969-1976		0,8	B6S	3510		
4W	4		1969-1976		0,8	B6S	3510		
Ultra	4		1987-1988		0,8	BZ7HS-10	3579		
Excel	4		1987-1988		0,8	BZ7HS-10	3579		
Angler	5		1965-1968		0,8	B6S	3510		
LD	5		1965-1968		0,8	B6S	3510		
Lightwin	5,2		2 1952-1974		0,8	B6S	3510		
Fisherman	5,5		2 1956-1974		0,8	B6S	3510		
CD	5,5		1954-1964		0,8	B6S	3510		
Fisherman	6		2 1956-1974		0,8	B6S	3510		
6R	6		1971-1976		0,8	B6S	3510		
6RL	6		1971-1976		0,8	B6S	3510		
CD	6		1965-1968		0,8	B6S	3510		
COM	6,5		1981-1993		0,8	BR6HS	3922	BR6HIX	3419
COM	7,5		1977-2003		0,8	BZ7HS-10	3579		
COM	8		1977-1998		0,8	BR6HS	3922	BR6HIX	3419
9R	9		1974-		0,8	BZ7HS-10	3579		
9RL	9		1974-		0,8	BZ7HS-10	3579		



HP







c
c
mC
y
l

Stock-Nº

FRIBUM

Stock-NºX

9EL	9		1974-		0,8	BZ7HS-10	3579		
Sportwin	9,5	2	1956-1973		0,8	B6S	3510		
MQ	9,5		1964-1968		0,8	B6S	3510		
Big Bore	9,9		1993-2006		0,8	BR6HS	3922	BR6HIX	3419
Sportwin	10	2	1956-1973		0,8	B6S	3510		
10E	10		1975-1976		0,8	BZ7HS-10	3579		
10EL	10		1975-1976		0,8	BZ7HS-10	3579		
10R	10		1975-1976		0,8	BZ7HS-10	3579		
10RL	10		1975-1976		0,8	BZ7HS-10	3579		
COM	10		1981-1982		-	BUHW-2	5626		
COM	10		1992-1993		0,8	BZ7HS-10	3579		
COM	10		1994-2003		0,8	BR7HS	4122	BR7HIX	7067
COM	14		1981-		-	BUHW-2	5626		
COM	14		1981-1991		0,8	BZ7HS-10	3579		
15E	15		1974-1976		0,8	BZ7HS-10	3579		
15EL	15		1974-1976		0,8	BZ7HS-10	3579		
15R	15		1974-1976		0,8	BZ7HS-10	3579		
15RL	15		1974-1976		0,8	BZ7HS-10	3579		
COM	15		1992-1993		0,8	BZ7HS-10	3579		
COM	15		1994-2001		0,8	BR7HS	4122	BR7HIX	7067
Kero	15		1995-1998		0,8	BUHXW-1	5526		
E15DHPLISS	15		2000-		1,1	IZFR6N-E	4757		
E15DHTLISS	15		2000-		1,1	IZFR6N-E	4757		
E15DHPLIIC	15	2	2011-		1,1	IZFR6N-E	4757		
E15DHPLIIH	15	2	2011-		1,1	IZFR6N-E	4757		
E15DHTLIIC	15	2	2011-		1,1	IZFR6N-E	4757		
E15DHTLIH	15	2	2011-		1,1	IZFR6N-E	4757		
E15HPSLIH	15	2	2011-		1,1	IZFR6N-E	4757		
E15HPSLIIS	15	2	2011-		1,1	IZFR6N-E	4757		
E15HTSLIHH	15	2	2011-		1,1	IZFR6N-E	4757		
E15HTSLIIS	15	2	2011-		1,1	IZFR6N-E	4757		
E15DHPLINR	15	2	2012-		1,1	IZFR6N-E	4757		
E15DHTLINR	15	2	2012-		1,1	IZFR6N-E	4757		
E15HPSLINC	15	2	2012-		1,1	IZFR6N-E	4757		
E15HPSXINC	15	2	2012-		1,1	IZFR6N-E	4757		
E15HTSLINC	15	2	2012-		1,1	IZFR6N-E	4757		
E15HTSXINC	15	2	2012-		1,1	IZFR6N-E	4757		
Fastwin	18	2	1957-1973		0,8	B8S	3810		
Jet	18	2	1995-1998		0,8	BR7HS	4122	BR7HIX	7067
FD	18		1956-1965		0,8	B6S	3510		
FDE	18		1956-1968		0,8	B6S	3510		
20R	20		1969-1972		0,8	B6S	3510		
25R	20		1969-1972		0,8	B6S	3510		
20RL	20		1971-1972		0,8	B6S	3510		
25RL	20		1971-1972		0,8	B6S	3510		
20R	20		1973-		0,8	B6S	3510		
20RL	20		1973-		0,8	B6S	3510		
FD	20		1966-1968		0,8	B6S	3510		
Bigwin	25		1951-1970		0,8	B8S	3810		
20R	25		1969-1972		0,8	B6S	3510		
25R	25		1969-1972		0,8	B6S	3510		
20RL	25		1971-1972		0,8	B6S	3510		
25RL	25		1971-1972		0,8	B6S	3510		

	HP	c c m	C y l					Stock-Nº		Stock-NºX
25E	25			1972-1976			0,8	B6S	3510	
25EL	25			1972-1976			0,8	B6S	3510	
25R	25			1973-1976			0,8	B6S	3510	
25RL	25			1973-1976			0,8	B6S	3510	
Evinrude 25	25			1978-1993			0,8	BZ7HS-10	3579	
COM	25			1981-1998			-	BUHXW-1	5526	
Commercial	25			1999-2001			-	BUHXW-1	5526	
E25DELSES	25		2	2009-			1,1	IZFR6F11	4095	
E25DPLSES	25		2	2009-			1,1	IZFR6F11	4095	
E25DRLSES	25		2	2009-			1,1	IZFR6F11	4095	
E25DRSES	25		2	2009-			1,1	IZFR6F11	4095	
E25DTELSSES	25		2	2009-			1,1	IZFR6F11	4095	
E25DTESES	25		2	2009-			1,1	IZFR6F11	4095	
E25DTLSES	25		2	2009-			1,1	IZFR6F11	4095	
E25DELISC	25		2	2010-			1,1	IZFR6N-E	4757	
E25DPLISC	25		2	2010-			1,1	IZFR6N-E	4757	
E25DRISC	25		2	2010-			1,1	IZFR6N-E	4757	
E25DRLISC	25		2	2010-			1,1	IZFR6N-E	4757	
E25DTEISC	25		2	2010-			1,1	IZFR6N-E	4757	
E25DTELISC	25		2	2010-			1,1	IZFR6N-E	4757	
E25DTLISC	25		2	2010-			1,1	IZFR6N-E	4757	
E25DELIH	25		2	2011-			1,1	IZFR6N-E	4757	
E25DELIIR	25		2	2011-			1,1	IZFR6N-E	4757	
E25DPLIIG	25		2	2011-			1,1	IZFR6N-E	4757	
E25DPLIHH	25		2	2011-			1,1	IZFR6N-E	4757	
E25DPLIIR	25		2	2011-			1,1	IZFR6N-E	4757	
E25DPSLIHH	25		2	2011-			1,1	IZFR6N-E	4757	
E25DPSLIIS	25		2	2011-			1,1	IZFR6N-E	4757	
E25DRIHH	25		2	2011-			1,1	IZFR6N-E	4757	
E25DRIIR	25		2	2011-			1,1	IZFR6N-E	4757	
E25DRLIHH	25		2	2011-			1,1	IZFR6N-E	4757	
E25DRLIIR	25		2	2011-			1,1	IZFR6N-E	4757	
E25DRSIHH	25		2	2011-			1,1	IZFR6N-E	4757	
E25DRSIIS	25		2	2011-			1,1	IZFR6N-E	4757	
E25DRSLIHH	25		2	2011-			1,1	IZFR6N-E	4757	
E25DRSLIIS	25		2	2011-			1,1	IZFR6N-E	4757	
E25DTEIIG	25		2	2011-			1,1	IZFR6N-E	4757	
E25DTEIHH	25		2	2011-			1,1	IZFR6N-E	4757	
E25DTEIIR	25		2	2011-			1,1	IZFR6N-E	4757	
E25DTELIHH	25		2	2011-			1,1	IZFR6N-E	4757	
E25DTELIIR	25		2	2011-			1,1	IZFR6N-E	4757	
E25DTLIHH	25		2	2011-			1,1	IZFR6N-E	4757	
E25DTLIIR	25		2	2011-			1,1	IZFR6N-E	4757	
E25DTSLIHH	25		2	2011-			1,1	IZFR6N-E	4757	
E25DTSLIIS	25		2	2011-			1,1	IZFR6N-E	4757	
E25TESLIHH	25		2	2011-			1,1	IZFR6N-E	4757	
E25TESLIIS	25		2	2011-			1,1	IZFR6N-E	4757	
E25DELINA	25		2	2012-			1,1	IZFR6N-E	4757	
E25DPLINA	25		2	2012-			1,1	IZFR6N-E	4757	
E25DPSLINC	25		2	2012-			1,1	IZFR6N-E	4757	
E25DRINA	25		2	2012-			1,1	IZFR6N-E	4757	
E25DRLINA	25		2	2012-			1,1	IZFR6N-E	4757	
E25DRSINC	25		2	2012-			1,1	IZFR6N-E	4757	



HP







c
c
mC
y
l

Stock-Nr

FRIDUM

Stock-NrX

E25DRSLINC	25		2	2012-		1,1	IZFR6N-E	4757		
E25DTEINA	25		2	2012-		1,1	IZFR6N-E	4757		
E25DETELINA	25		2	2012-		1,1	IZFR6N-E	4757		
E25DTLINA	25		2	2012-		1,1	IZFR6N-E	4757		
E25DTSLINC	25		2	2012-		1,1	IZFR6N-E	4757		
E25TESLINC	25		2	2012-		1,1	IZFR6N-E	4757		
RD	25			1951-1955		0,8	B6S	3510		
RDE	25			1954-1955		0,8	B6S	3510		
28 Jet	28			1992-2003		0,8	BPZ8HS-10	3133		
RX	28			1962-1964		0,8	B6S	3510		
RXE	28			1963-1964		0,8	B6S	3510		
Bigwin	30			1951-1970		0,8	B8S	3810		
E30DELSES	30		2	2009-		1,1	IZFR6F11	4095		
E30DPLSES	30		2	2009-		1,1	IZFR6F11	4095		
E30DRLSES	30		2	2009-		1,1	IZFR6F11	4095		
E30DRSES	30		2	2009-		1,1	IZFR6F11	4095		
E30DTELSSES	30		2	2009-		1,1	IZFR6F11	4095		
E30DTLSES	30		2	2009-		1,1	IZFR6F11	4095		
E30DELISC	30		2	2010-		1,1	IZFR6N-E	4757		
E30DPLISC	30		2	2010-		1,1	IZFR6N-E	4757		
E30DRISC	30		2	2010-		1,1	IZFR6N-E	4757		
E30DRLISC	30		2	2010-		1,1	IZFR6N-E	4757		
E30DTELISC	30		2	2010-		1,1	IZFR6N-E	4757		
E30DTLISC	30		2	2010-		1,1	IZFR6N-E	4757		
E30DELIH	30		2	2011-		1,1	IZFR6N-E	4757		
E30DELIIR	30		2	2011-		1,1	IZFR6N-E	4757		
E30DPLIH	30		2	2011-		1,1	IZFR6N-E	4757		
E30DPLIIR	30		2	2011-		1,1	IZFR6N-E	4757		
E30DPSLIH	30		2	2011-		1,1	IZFR6N-E	4757		
E30DPSLIIS	30		2	2011-		1,1	IZFR6N-E	4757		
E30DRIIG	30		2	2011-		1,1	IZFR6N-E	4757		
E30DRIIH	30		2	2011-		1,1	IZFR6N-E	4757		
E30DRIIR	30		2	2011-		1,1	IZFR6N-E	4757		
E30DRLIIG	30		2	2011-		1,1	IZFR6N-E	4757		
E30DRLIH	30		2	2011-		1,1	IZFR6N-E	4757		
E30DRLIIR	30		2	2011-		1,1	IZFR6N-E	4757		
E30DRSIH	30		2	2011-		1,1	IZFR6N-E	4757		
E30DRSIIS	30		2	2011-		1,1	IZFR6N-E	4757		
E30DRSLIH	30		2	2011-		1,1	IZFR6N-E	4757		
E30DRSLIIS	30		2	2011-		1,1	IZFR6N-E	4757		
E30DTELIH	30		2	2011-		1,1	IZFR6N-E	4757		
E30DTELIIR	30		2	2011-		1,1	IZFR6N-E	4757		
E30DTLIH	30		2	2011-		1,1	IZFR6N-E	4757		
E30DTLIIR	30		2	2011-		1,1	IZFR6N-E	4757		
E30DTSLIH	30		2	2011-		1,1	IZFR6N-E	4757		
E30DTSLIIS	30		2	2011-		1,1	IZFR6N-E	4757		
E30TESLIH	30		2	2011-		1,1	IZFR6N-E	4757		
E30TESLIIS	30		2	2011-		1,1	IZFR6N-E	4757		
E30DELINA	30		2	2012-		1,1	IZFR6N-E	4757		
E30DPLINA	30		2	2012-		1,1	IZFR6N-E	4757		
E30DPSLINC	30		2	2012-		1,1	IZFR6N-E	4757		
E30DRINA	30		2	2012-		1,1	IZFR6N-E	4757		
E30DRLINA	30		2	2012-		1,1	IZFR6N-E	4757		

	HP	c m	C y l					Stock-Nº		Stock-NºX
E30DRSINC	30		2	2012-			1,1	IZFR6N-E	4757	
E30DRSLINC	30		2	2012-			1,1	IZFR6N-E	4757	
E30DTELINA	30		2	2012-			1,1	IZFR6N-E	4757	
E30DTLINA	30		2	2012-			1,1	IZFR6N-E	4757	
E30DTSLINC	30		2	2012-			1,1	IZFR6N-E	4757	
E30TESLINC	30		2	2012-			1,1	IZFR6N-E	4757	
RD	30			1956-1956			0,8	B6S	3510	
RDE	30			1956-1956			0,8	B6S	3510	
RJE	30			1956-1956			0,8	B6S	3510	
RX	33			1965-1968			0,8	B6S	3510	
RXE	33			1965-1968			0,8	B6S	3510	
Bigwin	35			1951-1970			0,8	B8S	3810	
RD	35			1957-1958			0,8	B6S	3510	
RDE	35			1957-1958			0,8	B6S	3510	
RJE	35			1957-1957			0,8	B6S	3510	
RDS	35			1958-1959			0,8	B6S	3510	
Bigwin	40			1951-1970			0,8	B8S	3810	
40E	40			1969-1973			0,8	B6S	3510	
40EL	40			1969-1973			0,8	B6S	3510	
40R	40			1969-1973			0,8	B6S	3510	
40RL	40			1969-1973			0,8	B6S	3510	
40E	40			1974-1976			0,8	BZ7HS-10	3579	
40EL	40			1974-1976			0,8	BZ7HS-10	3579	
40R	40			1974-1976			0,8	BZ7HS-10	3579	
40RL	40			1974-1976			0,8	BZ7HS-10	3579	
COM43 cid	40			1981-1990			0,8	B7HS	5110	BR7HIX 7067
E-Tec	40			2004-2005			0,8	PZFR6H	7696	
E40DELSOR	40		2	2005-			0,8	PZFR6H	7696	
E40DPLSOR	40		2	2005-			0,8	PZFR6H	7696	
E40DRLSOR	40		2	2005-			0,8	PZFR6H	7696	
E-Tec 40 Inline 2	40		2	2006-2008			0,8	IZFR6N-E	4757	
E40DELSDA	40		2	2006-			0,8	IZFR6N-E	4757	
E40DPLSDA	40		2	2006-			0,8	IZFR6N-E	4757	
E40DRLSDA	40		2	2006-			0,8	IZFR6N-E	4757	
E40DPLSUM	40		2	2007-			0,8	IZFR6N-E	4757	
E40DRLSUM	40		2	2007-			0,8	IZFR6N-E	4757	
E40DP	40		2	2008-			1,1	IZFR6F11	4095	
E40DRLSCB	40		2	2008-			1,1	IZFR6F11	4095	
E40DSLSCS	40		2	2008-			1,1	IZFR6F11	4095	
E40DTLSCS	40		2	2008-			1,1	IZFR6F11	4095	
E40DPLSEE	40		2	2009-			1,1	IZFR6F11	4095	
E40DRLSEE	40		2	2009-			1,1	IZFR6F11	4095	
E40DSLSEC	40		2	2009-			1,1	IZFR6F11	4095	
E40DPLISD	40		2	2010-			1,1	IZFR6N-E	4757	
E40DPLISF	40		2	2010-			1,1	IZFR6N-E	4757	
E40DRLISD	40		2	2010-			1,1	IZFR6N-E	4757	
E40DRLISF	40		2	2010-			1,1	IZFR6N-E	4757	
E40DTLISF	40		2	2010-			1,1	IZFR6N-E	4757	
E40DTLISR	40		2	2010-			1,1	IZFR6N-E	4757	
E40DPLIIS	40		2	2011-			1,1	IZFR6N-E	4757	
E40DRLIIS	40		2	2011-			1,1	IZFR6N-E	4757	
E40DSLIIA	40		2	2011-			1,1	IZFR6N-E	4757	
E40DTLIIA	40		2	2011-			1,1	IZFR6N-E	4757	



HP







c
c
mC
y
l

Stock-Nr

FRIDUM

Stock-NrX

E40DHLINS	40		2	2012-		1,1	IZFR6N-E	4757		
E40DHLINS	40		2	2012-		1,1	IZFR6N-E	4757		
E40DPLINC	40		2	2012-		1,1	IZFR6N-E	4757		
E40DRLINC	40		2	2012-		1,1	IZFR6N-E	4757		
E40DSLINM	40		2	2012-		1,1	IZFR6N-E	4757		
E40DTLINM	40		2	2012-		1,1	IZFR6N-E	4757		
RD	40			1958-1968		0,8	B6S	3510		
RDS	40			1960-1968		0,8	B6S	3510		
RK	40			1962-1968		0,8	B6S	3510		
COM	45			1986-1990		-	BUZHW-2	2173		
COM	45			1991-2003		-	BUHXW-1	5526		
E-Tec	50			2004-2005		0,8	PZFR6H	7696		
E50DPLSOR	50		2	2005-		0,8	PZFR6H	7696		
E-Tec 50 Inline 2	50		2	2006-2008		0,8	IZFR6N-E	4757		
E50DPLSDA	50		2	2006-		0,8	IZFR6N-E	4757		
E50DPLSUM	50		2	2007-		0,8	IZFR6N-E	4757		
E50DPLSCB	50		2	2008-		1,1	IZFR6F11	4095		
E50DSLSCS	50		2	2008-		1,1	IZFR6F11	4095		
E50DTLSCS	50		2	2008-		1,1	IZFR6F11	4095		
E50DPLSEE	50		2	2009-		1,1	IZFR6F11	4095		
E50DSLSEC	50		2	2009-		1,1	IZFR6F11	4095		
E50DTLSEC	50		2	2009-		1,1	IZFR6F11	4095		
E50DPLISD	50		2	2010-		1,1	IZFR6N-E	4757		
E50DPLISF	50		2	2010-		1,1	IZFR6N-E	4757		
E50DSLISF	50		2	2010-		1,1	IZFR6N-E	4757		
E50DSLISR	50		2	2010-		1,1	IZFR6N-E	4757		
E50DTLISF	50		2	2010-		1,1	IZFR6N-E	4757		
E50DTLISR	50		2	2010-		1,1	IZFR6N-E	4757		
E50DPLIIS	50		2	2011-		1,1	IZFR6N-E	4757		
E50DSLIIA	50		2	2011-		1,1	IZFR6N-E	4757		
E50DTLIIA	50		2	2011-		1,1	IZFR6N-E	4757		
E50DSLINM	50		2	2012-		1,1	IZFR6N-E	4757		
E50DTLINM	50		2	2012-		1,1	IZFR6N-E	4757		
E50DPLINC	50		2	2012-		1,1	IZFR6N-E	4757		
Super Six-O	55			1971-		-	BUHW	2622		
COM	55			1986-2003		-	BUHXW-1	5526		
COM	55		2	1994-1995		0,8	BPZ8HS-10	3133		
E55MJRLSCC	55		2	2008-		1,1	IZFR6F11	4095		
E55MRLSCC	55		2	2008-		1,1	IZFR6F11	4095		
E55MJRLSEF	55		2	2009-		1,1	IZFR6N-E	4757		
E55MJRLSER	55		2	2009-		1,1	IZFR6F11	4095		
E55MRLSEF	55		2	2009-		1,1	IZFR6N-E	4757		
E55MRLSER	55		2	2009-		1,1	IZFR6F11	4095		
E55MJRLISA	55		2	2010-		1,1	IZFR6N-E	4757		
E55MRLISA	55		2	2010-		1,1	IZFR6N-E	4757		
E55MJRLIIM	55		2	2011-		1,1	IZFR6N-E	4757		
E55MRLIIM	55		2	2011-		1,1	IZFR6N-E	4757		
E55MJRLINB	55		2	2012-		1,1	IZFR6N-E	4757		
E55MRLINB	55		2	2012-		1,1	IZFR6N-E	4757		
Surper Six-O	60			1971-		-	BUHW	2622		
E-Tec	60		2	2005-		0,8	PZFR6H	7696		
E60WDRLSOS	60		2	2005-		0,8	PZFR6H	7696		
E60WDRYSOS	60		2	2005-		0,8	PZFR6H	7696		

	HP	c c m	C y l					Stock-Nº		Stock-NºX	
E-Tec 60 Inline 2	60		2	2006-2008			0,8	IZFR6N-E	4757		
E60DPLSDA	60		2	2006-			0,8	IZFR6N-E	4757		
E60DPLSUM	60		2	2007-			0,8	IZFR6N-E	4757		
Triumph	60		3	1970-1971			-	BUHW	2622		
V4	60		4	1964-1967			0,8	B6S	3510		
E60DPLSCB	60		2	2008-			1,1	IZFR6F11	4095		
E60DSLSCS	60		2	2008-			1,1	IZFR6F11	4095		
E60DTLSCS	60		2	2008-			1,1	IZFR6F11	4095		
E60DPLSEE	60		2	2009-			1,1	IZFR6F11	4095		
E60DSLSEC	60		2	2009-			1,1	IZFR6F11	4095		
E60DTLSEC	60		2	2009-			1,1	IZFR6F11	4095		
E60DPLISD	60		2	2010-			1,1	IZFR6N-E	4757		
E60DPLISF	60		2	2010-			1,1	IZFR6N-E	4757		
E60DSLISF	60		2	2010-			1,1	IZFR6N-E	4757		
E60DSLISR	60		2	2010-			1,1	IZFR6N-E	4757		
E60DTLISF	60		2	2010-			1,1	IZFR6N-E	4757		
E60DTLISR	60		2	2010-			1,1	IZFR6N-E	4757		
E60DPLIIS	60		2	2011-			1,1	IZFR6N-E	4757		
E60DSLIIA	60		2	2011-			1,1	IZFR6N-E	4757		
E60DTLIIA	60		2	2011-			1,1	IZFR6N-E	4757		
E60DPLINC	60		2	2012-			1,1	IZFR6N-E	4757		
E60DSLINM	60		2	2012-			1,1	IZFR6N-E	4757		
E60DTLINM	60		2	2012-			1,1	IZFR6N-E	4757		
V4 Sportfour	65		4	1968-			0,8	BZ7HS-10	3579		
COM HC LC	65			1984-1987			0,8	BZ7HS-10	3579		
COM HC LC	65			1988-1997			-	BUHXW-1	5526		
CV4 65 Jet	65			1992-1997			0,8	BR7HS	4122	BR7HIX	7067
COM	65		3	1994-1995			0,8	BPZ8HS-10	3133		
E65WDRLSCS	65		2	2008-			1,1	IZFR6F11	4095		
E65WDRYSCS	65		2	2008-			1,1	IZFR6F11	4095		
Triumph	65		3	1972-1973			0,8	B7HS	5110	BR7HIX	7067
E65WDRLSEC	65		2	2009-			1,1	IZFR6F11	4095		
E65WDRYSEC	65		2	2009-			1,1	IZFR6F11	4095		
E65WDRLISF	65		2	2010-			1,1	IZFR6N-E	4757		
E65WDRLISR	65		2	2010-			1,1	IZFR6N-E	4757		
E65WDRYISF	65		2	2010-			1,1	IZFR6N-E	4757		
E65WDRYISR	65		2	2010-			1,1	IZFR6N-E	4757		
E65WDRLIIA	65		2	2011-			1,1	IZFR6N-E	4757		
E65WDRYIIA	65		2	2011-			1,1	IZFR6N-E	4757		
E65WDRLINM	65		2	2012-			1,1	IZFR6N-E	4757		
E65WDRYINM	65		2	2012-			1,1	IZFR6N-E	4757		
Backtroller	70		3	1994-1997			0,8	BPR7HS	6422	BPR7HIX	5944
E-TEC	75			2004-2005			0,8	PZFR6H	7696		
E75DPLSOR	75		3	2005-			0,8	PZFR6H	7696		
E-TEC	75		3	2006-			0,8	IZFR6N-E	4757		
E75DPLSDA	75		3	2006-			0,8	IZFR6N-E	4757		
E75DPLSUM	75		3	2007-			0,8	IZFR6N-E	4757		
E75DPLSCB	75		3	2008-			1,1	IZFR6F11	4095		
E75DSLSCS	75		3	2008-			1,1	IZFR6F11	4095		
V4	75		4	1960-1965			0,8	B6S	3510		
E75DPLSEE	75		3	2009-			1,1	IZFR6F11	4095		
E75DSLSEC	75		3	2009-			1,1	IZFR6F11	4095		
E75DPLISD	75		3	2010-			1,1	IZFR6N-E	4757		



HP







c
mC
y
l

Stock-Nº

FRIBUM

Stock-NºX

E75DPLISF	75		3	2010-		1,1	IZFR6N-E	4757		
E75DSLISF	75		3	2010-		1,1	IZFR6N-E	4757		
E75DSLISR	75		3	2010-		1,1	IZFR6N-E	4757		
E75DPLIIS	75		3	2011-		1,1	IZFR6N-E	4757		
E75DSLIIA	75		3	2011-		1,1	IZFR6N-E	4757		
E75DPLINC	75		3	2012-		1,1	IZFR6N-E	4757		
E75DSLINM	75		3	2012-		1,1	IZFR6N-E	4757		
Starfire	80		4	1966-1967		0,8	B8S	3810		
Jet CV4	80			1979-1998		0,8	BR7HS	4122	BR7HIX	7067
V4 Backtroller	85		4	1994-1995		0,8	BR7HS	4122	BR7HIX	7067
SPL CV4	88			1979-1997		0,8	BR7HS	4122	BR7HIX	7067
CV4	90			1979-1998		0,8	BR7HS	4122	BR7HIX	7067
Turbojet CV4	90			1994-1997		0,8	BR7HS	4122	BR7HIX	7067
LV4	90			1995-1998		0,8	BPZ8HS-10	3133		
LV4 F.F.I.	90			1998-2000		0,8	PZFR6H	7696		
E-Tec	90			2004-2005		0,8	PZFR6H	7696		
E90DPLSOR	90		3	2005-		0,8	PZFR6H	7696		
E90DPXSOR	90		3	2005-		0,8	PZFR6H	7696		
E90DSLIOC	90		3	2005-		0,8	PZFR6H	7696		
E90WDPLSOS	90		3	2005-		0,8	PZFR6H	7696		
E-Tec I3	90	1300	3	2006-2008		0,8	IZFR6N-E	4757		
E90DPLSDA	90		3	2006-		0,8	IZFR6N-E	4757		
E90DPXSDA	90		3	2006-		0,8	IZFR6N-E	4757		
E90DSLSDR	90		3	2006-		0,8	IZFR6N-E	4757		
E90DPLSUM	90		3	2007-		0,8	IZFR6N-E	4757		
E90DPXSUM	90		3	2007-		0,8	IZFR6N-E	4757		
E90DSLSUM	90		3	2007-		0,8	IZFR6N-E	4757		
E90DPLSCB	90		3	2008-		1,1	IZFR6F11	4095		
E90DPXSCB	90		3	2008-		1,1	IZFR6F11	4095		
E90DSLSCM	90		3	2008-		1,1	IZFR6F11	4095		
E90WDELSCS	90		3	2008-		1,1	IZFR6F11	4095		
E90WDEXSCS	90		3	2008-		1,1	IZFR6F11	4095		
E90DMXSES	90		3	2009-		0,8	IZFR6N-E	4757		
E90DPLSEE	90		3	2009-		1,1	IZFR6F11	4095		
E90DPXSEE	90		3	2009-		1,1	IZFR6F11	4095		
E90DSLSEB	90		3	2009-		1,1	IZFR6F11	4095		
E90WDELSEC	90		3	2009-		1,1	IZFR6F11	4095		
E90WDEXSEC	90		3	2009-		1,1	IZFR6F11	4095		
E90DPLISD	90		3	2010-		0,8	IZFR6N-E	4757		
E90DPLISF	90		3	2010-		0,8	IZFR6N-E	4757		
E90DPXISD	90		3	2010-		0,8	IZFR6N-E	4757		
E90DPXISF	90		3	2010-		0,8	IZFR6N-E	4757		
E90DSLISE	90		3	2010-		0,8	IZFR6N-E	4757		
E90DSLISF	90		3	2010-		0,8	IZFR6N-E	4757		
E90WDELISF	90		3	2010-		0,8	IZFR6N-E	4757		
E90WDELISR	90		3	2010-		0,8	IZFR6N-E	4757		
E90WDEXISF	90		3	2010-		0,8	IZFR6N-E	4757		
E90WDEXISR	90		3	2010-		0,8	IZFR6N-E	4757		
E90DPLIIS	90		3	2011-		0,8	IZFR6N-E	4757		
E90DPXIIS	90		3	2011-		0,8	IZFR6N-E	4757		
E90DSLIID	90		3	2011-		0,8	IZFR6N-E	4757		
E90WDELIIA	90		3	2011-		0,8	IZFR6N-E	4757		
E90WDEXIIA	90		3	2011-		0,8	IZFR6N-E	4757		

	HP	c c m	C y l					Stock-No		Stock-NrX
E90DPLINC	90		3	2012-		0,8	IZFR6N-E	4757		
E90DXLINC	90		3	2012-		0,8	IZFR6N-E	4757		
E90DSLINC	90		3	2012-		0,8	IZFR6N-E	4757		
E90WDELINM	90		3	2012-		0,8	IZFR6N-E	4757		
E90WDEXINM	90		3	2012-		0,8	IZFR6N-E	4757		
Starfire	100		4	1967-1972		0,8	B7HS	5110	BR7HIX	7067
V4	100			1979-1980		0,8	B7HS	5110	BR7HIX	7067
COM	100			1984-1998		-	BUHXW-1	5526		
E100FPLSOC	100		4	2005-		1,1	PZFR6F-11	3271		
E100FSLSOC	100		4	2005-		1,1	PZFR6F-11	3271		
DI	100		4	2004-2005		0,8	PZFR6H	7696		
V4ML	100			1966-1966		0,8	B6S	3510		
105 Jet LV6	105		6	1993-2003		0,8	BPZ8HS-10	3133		
COM LV4	105		4	1997-2003		0,8	BPZ8HS-10	3133		
CV4	110			1979-1997		0,8	BR7HS	4122	BR7HIX	7067
CV4	112		4	1979-1997		0,8	BR7HS	4122	BR7HIX	7067
X-115	115			1967-1968		-	BUHW	2622		
COM	115			1975-1984		0,8	BZ7HS-10	3579		
Turbojet CV4	115			1994-1998		0,8	BR7HS	4122	BR7HIX	7067
Intruder LV4	115			1995-1998		0,8	BPZ8HS-10	3133		
LV4 F.F.I.	115			1998-2003		0,8	PZFR6H	7696		
E115FPLSOD	115		4	2005-		1,1	PZFR6F-11	3271		
E115FPXSOD	115		4	2005-		1,1	PZFR6F-11	3271		
E115FSLSOD	115		4	2005-		1,1	PZFR6F-11	3271		
E115FPLSDS	115		4	2006-		1,1	PZFR6F-11	3271		
E115FPXSDS	115		4	2006-		1,1	PZFR6F-11	3271		
E115FSLSDS	115		4	2006-		1,1	PZFR6F-11	3271		
E115DBXSUC	115		4	2007-		0,8	IZFR6N-E	4757		
E115DPLSUC	115		4	2007-		0,8	IZFR6N-E	4757		
E115DPXSUC	115		4	2007-		0,8	IZFR6N-E	4757		
E115DSLUC	115		4	2007-		0,8	IZFR6N-E	4757		
E115DBXSCR	115		4	2008-		1,1	IZFR6F11	4095		
E115DCXSCS	115		4	2008-		1,1	IZFR6F11	4095		
E115DPLSCR	115		4	2008-		1,1	IZFR6F11	4095		
E115DPXSCR	115		4	2008-		1,1	IZFR6F11	4095		
E115DSLSCR	115		4	2008-		1,1	IZFR6F11	4095		
CV4	115		4	1979-1998		0,8	BR7HS	4122	BR7HIX	7067
E-Tec	115	1700	4	2007-2008		0,8	IZFR6N-E	4757		
E115DBXSEF	115		4	2009-		1,1	IZFR6F11	4095		
E115DCXSEF	115		4	2009-		1,1	IZFR6F11	4095		
E115DHLSES	115		4	2009-		1,1	IZFR6F11	4095		
E115DHXSES	115		4	2009-		1,1	IZFR6F11	4095		
E115DPLSEF	115		4	2009-		1,1	IZFR6F11	4095		
E115DPXSEF	115		4	2009-		1,1	IZFR6F11	4095		
E115DSLSEF	115		4	2009-		1,1	IZFR6F11	4095		
E115HSLSES	115		4	2009-		1,1	IZFR6F11	4095		
E115DBXISF	115		4	2010-		1,1	IZFR6N-E	4757		
E115DBXISM	115		4	2010-		1,1	IZFR6N-E	4757		
E115DCXISF	115		4	2010-		1,1	IZFR6N-E	4757		
E115DCXISR	115		4	2010-		1,1	IZFR6N-E	4757		
E115DHLISC	115		4	2010-		1,1	IZFR6N-E	4757		
E115DHXISC	115		4	2010-		1,1	IZFR6N-E	4757		
E115DHXISF	115		4	2010-		1,1	IZFR6N-E	4757		



HP







c
c
mC
y
l

Stock-Nº

FRIBUM

Stock-NºX

E115DPLISF	115		4	2010-		1,1	IZFR6N-E	4757		
E115DPLISM	115		4	2010-		1,1	IZFR6N-E	4757		
E115DPXISF	115		4	2010-		1,1	IZFR6N-E	4757		
E115DPXISM	115		4	2010-		1,1	IZFR6N-E	4757		
E115DSLISF	115		4	2010-		1,1	IZFR6N-E	4757		
E115DSLISM	115		4	2010-		1,1	IZFR6N-E	4757		
E115HSLISC	115		4	2010-		1,1	IZFR6N-E	4757		
E115HSLISF	115		4	2010-		1,1	IZFR6N-E	4757		
E115DBXIIB	115		4	2011-		1,1	IZFR6N-E	4757		
E115DCXIIA	115		4	2011-		1,1	IZFR6N-E	4757		
E115DHLIIR	115		4	2011-		1,1	IZFR6N-E	4757		
E115DHXIIR	115		4	2011-		1,1	IZFR6N-E	4757		
E115DPLIIB	115		4	2011-		1,1	IZFR6N-E	4757		
E115DPXIIB	115		4	2011-		1,1	IZFR6N-E	4757		
E115DSLIIIB	115		4	2011-		1,1	IZFR6N-E	4757		
E115DSLIIIR	115		4	2011-		1,1	IZFR6N-E	4757		
E115DBXINE	115		4	2012-		1,1	IZFR6N-E	4757		
E115DCXINM	115		4	2012-		1,1	IZFR6N-E	4757		
E115DHLINA	115		4	2012-		1,1	IZFR6N-E	4757		
E115DHXINA	115		4	2012-		1,1	IZFR6N-E	4757		
E115DPLINE	115		4	2012-		1,1	IZFR6N-E	4757		
E115DSLINA	115		4	2012-		1,1	IZFR6N-E	4757		
E115DPXINE	115		4	2012-		1,1	IZFR6N-E	4757		
E115HSLINA	115		4	2012-		1,1	IZFR6N-E	4757		
LV4	120		4	1985-2003		0,8	BPZ8HS-10	3133		
E130DCXSES	130		4	2009-		1,1	IZFR6F11	4095		
E130DPLSES	130		4	2009-		1,1	IZFR6F11	4095		
E130DPXSES	130		4	2009-		1,1	IZFR6F11	4095		
E130DSLSES	130		4	2009-		1,1	IZFR6F11	4095		
LV4	130		4	1985-2003		0,8	BPZ8HS-10	3133		
E130DCXISC	130		4	2010-		1,1	IZFR6N-E	4757		
E130DCXISF	130		4	2010-		1,1	IZFR6N-E	4757		
E130DPLISC	130		4	2010-		1,1	IZFR6N-E	4757		
E130DPLISF	130		4	2010-		1,1	IZFR6N-E	4757		
E130DPXISC	130		4	2010-		1,1	IZFR6N-E	4757		
E130DPXISF	130		4	2010-		1,1	IZFR6N-E	4757		
E130DSLISC	130		4	2010-		1,1	IZFR6N-E	4757		
E130DSLISF	130		4	2010-		1,1	IZFR6N-E	4757		
E130DCXIIR	130		4	2011-		1,1	IZFR6N-E	4757		
E130DPLIIR	130		4	2011-		1,1	IZFR6N-E	4757		
E130DPXIIR	130		4	2011-		1,1	IZFR6N-E	4757		
E130DSLIIIR	130		4	2011-		1,1	IZFR6N-E	4757		
E130DCXINA	130		4	2012-		1,1	IZFR6N-E	4757		
E130DPLINA	130		4	2012-		1,1	IZFR6N-E	4757		
E130DPXINA	130		4	2012-		1,1	IZFR6N-E	4757		
E130DSLINA	130		4	2012-		1,1	IZFR6N-E	4757		
140	140			1973-1984		-	BUHXW-1	5526		
LV4	140		4	1985-2003		0,8	BPZ8HS-10	3133		
Intruder L	150			1991-1998		0,8	BPZ8HS-10	3133		
COM L	150			1993-1998		0,8	BPZ8HS-10	3133		
E150DBXSUF	150		6	2007-		0,8	IZFR6N-E	4757		
E150DCXSUC	150		6	2007-		0,8	IZFR6N-E	4757		
E150DCXSUF	150		6	2007-		0,8	IZFR6N-E	4757		

	HP	ccm	Cyl					Stock-Nº		Stock-NºX
E150DHLSUC	150		6	2007-			0,8	IZFR6N-E	4757	
E150DHLSUF	150		6	2007-			0,8	IZFR6N-E	4757	
E150DPLSUC	150		6	2007-			0,8	IZFR6N-E	4757	
E150DPLSUF	150		6	2007-			0,8	IZFR6N-E	4757	
E150DPXSUC	150		6	2007-			0,8	IZFR6N-E	4757	
E150DPXSUF	150		6	2007-			0,8	IZFR6N-E	4757	
E150DSLSUC	150		6	2007-			0,8	IZFR6N-E	4757	
E150DSLSUF	150		6	2007-			0,8	IZFR6N-E	4757	
E150DBXSFC	150		6	2008-			1,1	IZFR6F11	4095	
E150DBXSFCR	150		6	2008-			1,1	IZFR6F11	4095	
E150DCXSFC	150		6	2008-			1,1	IZFR6F11	4095	
E150DCXSFCR	150		6	2008-			1,1	IZFR6F11	4095	
E150DHLSCF	150		6	2008-			1,1	IZFR6F11	4095	
E150DHLSCR	150		6	2008-			1,1	IZFR6F11	4095	
E150DPLSCR	150		6	2008-			1,1	IZFR6F11	4095	
E150DPXSFC	150		6	2008-			1,1	IZFR6F11	4095	
E150DPXSFCR	150		6	2008-			1,1	IZFR6F11	4095	
E150DSLSCR	150		6	2008-			1,1	IZFR6F11	4095	
E150HSLSCF	150		6	2008-			1,1	IZFR6F11	4095	
E150HSLSCS	150		6	2008-			1,1	IZFR6F11	4095	
E150DBXSEA	150		6	2009-			1,1	IZFR6F11	4095	
E150DCXSEA	150		6	2009-			1,1	IZFR6F11	4095	
E150DHLSEA	150		6	2009-			1,1	IZFR6F11	4095	
E150DPLSEA	150		6	2009-			1,1	IZFR6F11	4095	
E150DPXSEA	150		6	2009-			1,1	IZFR6F11	4095	
E150DSLSEA	150		6	2009-			1,1	IZFR6F11	4095	
E150HGLSES	150		6	2009-			1,1	IZFR6F11	4095	
E150HGXSES	150		6	2009-			1,1	IZFR6F11	4095	
E150HSLSEC	150		6	2009-			1,1	IZFR6F11	4095	
CV6	150		6	1978-1987			-	BUHXW-1	5526	
CV6	150		6	1988-1991			0,8	BZ7HS-10	3579	
E-Tec 150 I	150		6	2007-2008			0,8	IZFR6N-E	4757	
E-Tec 150 HO	150		6	2007-2008			0,8	IZFR6N-E	4757	
E150DBXISF	150		6	2010-			1,1	IZFR6N-E	4757	
E150DBXISM	150		6	2010-			1,1	IZFR6N-E	4757	
E150DCXISF	150		6	2010-			1,1	IZFR6N-E	4757	
E150DCXISM	150		6	2010-			1,1	IZFR6N-E	4757	
E150DHLISF	150		6	2010-			1,1	IZFR6N-E	4757	
E150DHLISM	150		6	2010-			1,1	IZFR6N-E	4757	
E150DPLISF	150		6	2010-			1,1	IZFR6N-E	4757	
E150DPLISM	150		6	2010-			1,1	IZFR6N-E	4757	
E150DPXISF	150		6	2010-			1,1	IZFR6N-E	4757	
E150DPXISM	150		6	2010-			1,1	IZFR6N-E	4757	
LV6 F.F.I.	150		6	1997-2003			0,8	PZFR6H	7696	
E150DSLISF	150		6	2010-			1,1	IZFR6N-E	4757	
E150DSLISM	150		6	2010-			1,1	IZFR6N-E	4757	
E150HSLISF	150		6	2010-			1,1	IZFR6N-E	4757	
E150HSLISR	150		6	2010-			1,1	IZFR6N-E	4757	
E150DBXIIB	150		6	2011-			1,1	IZFR6N-E	4757	
E150DCXIIB	150		6	2011-			1,1	IZFR6N-E	4757	
E150DHLIIB	150		6	2011-			1,1	IZFR6N-E	4757	
E150DPLIIB	150		6	2011-			1,1	IZFR6N-E	4757	
E150DPXIIB	150		6	2011-			1,1	IZFR6N-E	4757	



HP







c
c
mC
y
l

Stock-Nº

FRIBUM

Stock-NºX

E150DSLIIIB	150		6	2011-		1,1	IZFR6N-E	4757		
E150HSLIIA	150		6	2011-		1,1	IZFR6N-E	4757		
DE150CXINS	150		6	2012-		1,1	IZFR6N-E	4757		
DE150PXINS	150		6	2012-		1,1	IZFR6N-E	4757		
E150DBXINE	150		6	2012-		1,1	IZFR6N-E	4757		
E150DCXINE	150		6	2012-		1,1	IZFR6N-E	4757		
E150DHLINE	150		6	2012-		1,1	IZFR6N-E	4757		
E150DPLINE	150		6	2012-		1,1	IZFR6N-E	4757		
E150DPXINE	150		6	2012-		1,1	IZFR6N-E	4757		
E150DSLIIA	150		6	2012-		1,1	IZFR6N-E	4757		
E150HSLINM	150		6	2012-		1,1	IZFR6N-E	4757		
COM	155			1987-		-	BUHW-2	5626		
COM CV6	155		6	1989-1992		-	BUHXW-1	5526		
CV6	155		6	1978-1987		-	BUHXW-1	5526		
E175DCXSUF	175		6	2007-		0,8	IZFR6N-E	4757		
E175DPLSUF	175		6	2007-		0,8	IZFR6N-E	4757		
E175DPXSUF	175		6	2007-		0,8	IZFR6N-E	4757		
E175DLSUF	175		6	2007-		0,8	IZFR6N-E	4757		
E175DCXSCF	175		6	2008-		1,1	IZFR6F11	4095		
E175DCXSCR	175		6	2008-		1,1	IZFR6F11	4095		
E175DMXSCF	175		6	2008-		1,1	IZFR6F11	4095		
E175DMXSCR	175		6	2008-		0,8	IZFR6N-E	4757		
E175DPLSCR	175		6	2008-		1,1	IZFR6F11	4095		
E175DPXSCF	175		6	2008-		1,1	IZFR6F11	4095		
E175DPXSCR	175		6	2008-		1,1	IZFR6F11	4095		
E175DSLSCR	175		6	2008-		1,1	IZFR6F11	4095		
E175DCXSEA	175		6	2009-		1,1	IZFR6F11	4095		
E175DPLSEA	175		6	2009-		1,1	IZFR6F11	4095		
E175DPXSEA	175		6	2009-		1,1	IZFR6F11	4095		
E175DSLSEA	175		6	2009-		1,1	IZFR6F11	4095		
CV6	175		6	1988-1991		0,8	BZ7HS-10	3579		
E-Tec 175 I	175		6	2007-2008		0,8	IZFR6N-E	4757		
E175DCXISF	175		6	2010-		1,1	IZFR6N-E	4757		
E175DCXISM	175		6	2010-		1,1	IZFR6N-E	4757		
E175DPLISF	175		6	2010-		1,1	IZFR6N-E	4757		
E175DPLISM	175		6	2010-		1,1	IZFR6N-E	4757		
E175DPXISF	175		6	2010-		1,1	IZFR6N-E	4757		
E175DPXISM	175		6	2010-		1,1	IZFR6N-E	4757		
E175DSLISF	175		6	2010-		1,1	IZFR6N-E	4757		
E175DSLISM	175		6	2010-		1,1	IZFR6N-E	4757		
Intruder LV6	175		6	1991-1998		0,8	BPZ8HS-10	3133		
LV6 F.F.I.	175		6	1998-2003		0,8	PZFR6H	7696		
E175DCXIIB	175		6	2011-		1,1	IZFR6N-E	4757		
E175DPLIIB	175		6	2011-		1,1	IZFR6N-E	4757		
E175DPXIIB	175		6	2011-		1,1	IZFR6N-E	4757		
E175DSLIIIB	175		6	2011-		1,1	IZFR6N-E	4757		
E175DCXINE	175		6	2012-		1,1	IZFR6N-E	4757		
E175DPLINE	175		6	2012-		1,1	IZFR6N-E	4757		
E175DPXINE	175		6	2012-		1,1	IZFR6N-E	4757		
E175DSLIIA	175		6	2012-		1,1	IZFR6N-E	4757		
COM	185		6	1990-1994		0,8	BZ7HS-10	3579		
COM	200			1992-		-	BUHXW-1	5526		
COM	200			1993-1998		0,8	BPZ8HS-10	3133		

	HP	c c m	C y l					Stock-Nº		Stock-NºX
Vindicator L	200			1994-1998			0,8	BPZ8HS-10	3133	
DCXSOC	200		6	2005-			0,8	IZFR6N-E	4757	
DHLSOC	200		6	2005-			0,8	IZFR6N-E	4757	
DHLSOG	200		6	2005-			0,8	IZFR6N-E	4757	
DPLSOC	200		6	2005-			0,8	IZFR6N-E	4757	
DPXSOC	200		6	2005-			0,8	IZFR6N-E	4757	
DSLSOC	200		6	2005-			0,8	IZFR6N-E	4757	
E200DCXSOC	200		6	2005-			0,8	IZFR6N-E	4757	
E200DHLSOC	200		6	2005-			0,8	IZFR6N-E	4757	
E200DPXSOC	200		6	2005-			0,8	IZFR6N-E	4757	
E200DSLSOC	200		6	2005-			0,8	IZFR6N-E	4757	
F Models	200		6	2005-			0,8	PZFR6H	7696	
DHLSDF	200		6	2006-			0,8	IZFR6N-E	4757	
DHXSDS	200		6	2006-			0,8	IZFR6N-E	4757	
E200DHLSDF	200		6	2006-			0,8	IZFR6N-E	4757	
E200DHXSDS	200		6	2006-			0,8	IZFR6N-E	4757	
E200HCXSDS	200		6	2006-			0,8	IZFR6N-E	4757	
E200HSLSDS	200		6	2006-			0,8	IZFR6N-E	4757	
HCXSDS	200		6	2006-			0,8	IZFR6N-E	4757	
HSLSDS	200		6	2006-			0,8	IZFR6N-E	4757	
E200DCXSUF	200		6	2007-			0,8	IZFR6N-E	4757	
E200DCXSUR	200		6	2007-			0,8	IZFR6N-E	4757	
E200DHLSUA	200		6	2007-			0,8	IZFR6N-E	4757	
E200DHLSUG	200		6	2007-			0,8	IZFR6N-E	4757	
E200DHXSUC	200		6	2007-			0,8	IZFR6N-E	4757	
E200DPLSUF	200		6	2007-			0,8	IZFR6N-E	4757	
E200DPLSUR	200		6	2007-			0,8	IZFR6N-E	4757	
E200DPXSUF	200		6	2007-			0,8	IZFR6N-E	4757	
E200DPXSUR	200		6	2007-			0,8	IZFR6N-E	4757	
E200DSLSUF	200		6	2007-			0,8	IZFR6N-E	4757	
E200DSLSUR	200		6	2007-			0,8	IZFR6N-E	4757	
E200HCXSUC	200		6	2007-			0,8	IZFR6N-E	4757	
E200HLSUC	200		6	2007-			0,8	IZFR6N-E	4757	
E200DCXSACA	200		6	2008-			1,1	IZFR6F11	4095	
E200DCXSACF	200		6	2008-			1,1	IZFR6F11	4095	
E200DHLSACF	200		6	2008-			1,1	IZFR6F11	4095	
E200DHLSACG	200		6	2008-			1,1	IZFR6F11	4095	
E200DHLSACM	200		6	2008-			1,1	IZFR6F11	4095	
E200DHXSACF	200		6	2008-			1,1	IZFR6F11	4095	
E200DHXSACG	200		6	2008-			1,1	IZFR6F11	4095	
E200DHXSACR	200		6	2008-			1,1	IZFR6F11	4095	
E200DPLSACA	200		6	2008-			1,1	IZFR6F11	4095	
E200DPXSACA	200		6	2008-			1,1	IZFR6F11	4095	
E200DSLSACA	200		6	2008-			1,1	IZFR6F11	4095	
E200HCXSACF	200		6	2008-			1,1	IZFR6F11	4095	
E200HCXSACG	200		6	2008-			1,1	IZFR6F11	4095	
E200HCXSACR	200		6	2008-			1,1	IZFR6F11	4095	
E200HLSACF	200		6	2008-			1,1	IZFR6F11	4095	
E200HLSACG	200		6	2008-			1,1	IZFR6F11	4095	
E200HLSACR	200		6	2008-			1,1	IZFR6F11	4095	
E200HVLSCF	200		6	2008-			1,1	IZFR6F11	4095	
E200HVLSCG	200		6	2008-			1,1	IZFR6F11	4095	
E200HVLSCS	200		6	2008-			1,1	IZFR6F11	4095	



HP





c
mC
y
l

Stock-No

FRIDUM

Stock-NrX

E200DCXSEM	200		6	2009-		1,1	IZFR6F11	4095		
E200DPLSEM	200		6	2009-		1,1	IZFR6F11	4095		
E200DPXSEM	200		6	2009-		1,1	IZFR6F11	4095		
E200DSLSEM	200		6	2009-		1,1	IZFR6F11	4095		
E200DCXISB	200		6	2010-		1,1	IZFR6N-E	4757		
E200DCXISF	200		6	2010-		1,1	IZFR6N-E	4757		
E200DPLISB	200		6	2010-		1,1	IZFR6N-E	4757		
E200DPLISF	200		6	2010-		1,1	IZFR6N-E	4757		
E200DPXISB	200		6	2010-		1,1	IZFR6N-E	4757		
E200DPXISF	200		6	2010-		1,1	IZFR6N-E	4757		
E200DSLISB	200		6	2010-		1,1	IZFR6N-E	4757		
E200DSLISF	200		6	2010-		1,1	IZFR6N-E	4757		
DE200CXINS	200	2600	6	2012-		1,1	IZFR6N-E	4757		
DE200PXINS	200	2600	6	2012-		1,1	IZFR6N-E	4757		
E-Tec 200 HO	200		6	2007-2008		0,8	IZFR6N-E	4757		
E-Tec 200 I	200		6	2007-2008		0,8	IZFR6N-E	4757		
E200DCXIND	200		6	2012-		1,1	IZFR6N-E	4757		
E200DPLIND	200		6	2012-		1,1	IZFR6N-E	4757		
E200DPXIND	200		6	2012-		1,1	IZFR6N-E	4757		
E200DSLIND	200		6	2012-		1,1	IZFR6N-E	4757		
LV6 F.F.I.	200		6	1999-2004		0,8	PZFR6H	7696		
V6	200		6	1986-1993		0,8	BZ7HS-10	3579		
E200DCXIIE	200		6	2011-		1,1	IZFR6N-E	4757		
E200DPLIIE	200		6	2011-		1,1	IZFR6N-E	4757		
E200DPXIIE	200		6	2011-		1,1	IZFR6N-E	4757		
E200DSLIIIE	200		6	2011-		1,1	IZFR6N-E	4757		
Vindicator	225			1994-1998		0,8	BPZ8HS-10	3133		
DCXSOC	225		6	2005-		0,8	IZFR6N-E	4757		
DCZSOC	225		6	2005-		0,8	IZFR6N-E	4757		
DHLSOC	225		6	2005-		0,8	IZFR6N-E	4757		
DHLSOF	225		6	2005-		0,8	IZFR6N-E	4757		
DHLSOG	225		6	2005-		0,8	IZFR6N-E	4757		
DHXSOC	225		6	2005-		0,8	IZFR6N-E	4757		
DHXSOG	225		6	2005-		0,8	IZFR6N-E	4757		
DPLSOC	225		6	2005-		0,8	IZFR6N-E	4757		
DPXSOC	225		6	2005-		0,8	IZFR6N-E	4757		
DPZSDR	225		6	2005-		0,8	IZFR6N-E	4757		
DPZSOC	225		6	2005-		0,8	IZFR6N-E	4757		
F Models	225		6	2005-		0,8	PZFR6H	7696		
DCXSDR	225		6	2006-		0,8	IZFR6N-E	4757		
DCZSDR	225		6	2006-		0,8	IZFR6N-E	4757		
DHLSDF	225		6	2006-		0,8	IZFR6N-E	4757		
DHXSDF	225		6	2006-		0,8	IZFR6N-E	4757		
DPLSDR	225		6	2006-		0,8	IZFR6N-E	4757		
DPXSDR	225		6	2006-		0,8	IZFR6N-E	4757		
E225DCXSUA	225		6	2007-		1,1	IZFR6F11	4095		
E225DCZSUA	225		6	2007-		1,1	IZFR6F11	4095		
E225DCZSUG	225		6	2007-		1,1	IZFR6F11	4095		
E225DHLSUA	225		6	2007-		1,1	IZFR6F11	4095		
E225DHLSUG	225		6	2007-		1,1	IZFR6F11	4095		
E225DHXSUG	225		6	2007-		1,1	IZFR6F11	4095		
E225DHXSUR	225		6	2007-		1,1	IZFR6F11	4095		
E225DPLSUA	225		6	2007-		1,1	IZFR6F11	4095		

	HP	c c m	C y l					Stock-Nº		Stock-NºX	
E225DPLSUG	225		6	2007-				1,1	IZFR6F11	4095	
E225DPXSUA	225		6	2007-				1,1	IZFR6F11	4095	
E225DPXSUG	225		6	2007-				1,1	IZFR6F11	4095	
E225DCXSCF	225		6	2008-				1,1	IZFR6F11	4095	
E225DCXSCG	225		6	2008-				1,1	IZFR6F11	4095	
E225DCXSCM	225		6	2008-				1,1	IZFR6F11	4095	
E225DCZSCF	225		6	2008-				1,1	IZFR6F11	4095	
E225DCZSCG	225		6	2008-				1,1	IZFR6F11	4095	
E225DCZSCM	225		6	2008-				1,1	IZFR6F11	4095	
E225DHLSCF	225		6	2008-				1,1	IZFR6F11	4095	
E225DHLSCG	225		6	2008-				1,1	IZFR6F11	4095	
E225DHLSCM	225		6	2008-				1,1	IZFR6F11	4095	
E225DHXSCA	225		6	2008-				1,1	IZFR6F11	4095	
E225DHXSCF	225		6	2008-				1,1	IZFR6F11	4095	
E225DHXSCG	225		6	2008-				1,1	IZFR6F11	4095	
E225DPLSCF	225		6	2008-				1,1	IZFR6F11	4095	
E225DPLSCG	225		6	2008-				1,1	IZFR6F11	4095	
E225DPLSCM	225		6	2008-				1,1	IZFR6F11	4095	
E225DPXSCF	225		6	2008-				1,1	IZFR6F11	4095	
E225DPXSCG	225		6	2008-				1,1	IZFR6F11	4095	
E225DPXSCM	225		6	2008-				1,1	IZFR6F11	4095	
E225DPZSCF	225		6	2008-				1,1	IZFR6F11	4095	
E225DPZSCG	225		6	2008-				1,1	IZFR6F11	4095	
E225DPZSCM	225		6	2008-				1,1	IZFR6F11	4095	
E225HSLSCF	225		6	2008-				1,1	IZFR6F11	4095	
E225HSLSCG	225		6	2008-				1,1	IZFR6F11	4095	
E-Tec 225 HO	225		6	2007-2008				0,8	IZFR6N-E	4757	
E-Tec 225 I	225		6	2007-2008				0,8	IZFR6N-E	4757	
LV6 F.F.I.	225		6	1999-2004				0,8	PZFR6H	7696	
DCXSDR	250		6	2005-				0,8	IZFR6N-E	4757	
DCXSOC	250		6	2005-				0,8	IZFR6N-E	4757	
DCZSOC	250		6	2005-				0,8	IZFR6N-E	4757	
DPLSOC	250		6	2005-				0,8	IZFR6N-E	4757	
DPXSOC	250		6	2005-				0,8	IZFR6N-E	4757	
DPZSOC	250		6	2005-				0,8	IZFR6N-E	4757	
E250FCXSOB	250		6	2005-				0,8	PZFR6H	7696	
E250FCZSOB	250		6	2005-				0,8	PZFR6H	7696	
E250FPLSOM	250		6	2005-				0,8	PZFR6H	7696	
E250FPXSOB	250		6	2005-				0,8	PZFR6H	7696	
E250FPZSOB	250		6	2005-				0,8	PZFR6H	7696	
DCZSDR	250		6	2006-				0,8	IZFR6N-E	4757	
DPLSDR	250		6	2006-				0,8	IZFR6N-E	4757	
DPXSDR	250		6	2006-				0,8	IZFR6N-E	4757	
DPZSDR	250		6	2006-				0,8	IZFR6N-E	4757	
E250DCXSUA	250		6	2007-				1,1	IZFR6F11	4095	
E250DCXSUG	250		6	2007-				1,1	IZFR6F11	4095	
E250DCZSUA	250		6	2007-				1,1	IZFR6F11	4095	
E250DPLSUA	250		6	2007-				1,1	IZFR6F11	4095	
E250DPXSUA	250		6	2007-				1,1	IZFR6F11	4095	
E250DPXSUG	250		6	2007-				1,1	IZFR6F11	4095	
E250DPZSUA	250		6	2007-				1,1	IZFR6F11	4095	
E250DPZSUG	250		6	2007-				1,1	IZFR6F11	4095	
E250DCXSCF	250		6	2008-				1,1	IZFR6F11	4095	



HP

c
mC
y
l

Stock-Nr

FRIBUM

Stock-NrX

E250DCXSCG	250		6	2008-		1,1	IZFR6F11	4095		
E250DCXSCM	250		6	2008-		1,1	IZFR6F11	4095		
E250DCZSCF	250		6	2008-		1,1	IZFR6F11	4095		
E250DCZSCG	250		6	2008-		1,1	IZFR6F11	4095		
E250DCZSCM	250		6	2008-		1,1	IZFR6F11	4095		
E250DPLSCF	250		6	2008-		1,1	IZFR6F11	4095		
E250DPLSCG	250		6	2008-		1,1	IZFR6F11	4095		
E250DPLSCM	250		6	2008-		1,1	IZFR6F11	4095		
E250DPXSCF	250		6	2008-		1,1	IZFR6F11	4095		
E250DPXSCG	250		6	2008-		1,1	IZFR6F11	4095		
E250DPXSCM	250		6	2008-		1,1	IZFR6F11	4095		
E250DPZSCF	250		6	2008-		1,1	IZFR6F11	4095		
E250DPZSCG	250		6	2008-		1,1	IZFR6F11	4095		
E250DPZSCM	250		6	2008-		1,1	IZFR6F11	4095		
E-Tec 250 I	250		6	2007-2008		0,8	IZFR6N-E	4757		
F ModelsV8	250		8	2005-		0,8	PZFR6H	7696		
V8	250		8	1985-1998		0,8	BPZ8HS-10	3133		
V8	250		8	2003-2004		0,8	PZFR6H	7696		
V8	300		8	1985-1997		0,8	BPZ8HS-10	3133		

FIRESTONE

Featherweight 5	5			1966-		0,8	BR6S	3522		
-----------------	---	--	--	-------	--	-----	------	------	--	--

FISHER PIERCE

Bearcat 55	55		4	-		0,8	BR6S	3522		
Bearcat 85	85		4	-		0,8	BR8ES	5422	BR8EIX	5044

FLAMBEAU

Single	2,5			-		0,6	B6S	3510		
Double	5			-		0,6	B6S	3510		

GALE

Buccaneer 3	3			-		0,8	B6S	3510		
Buccaneer 5	5			-		0,8	B6S	3510		
Buccaneer 5.5	5,5			-		0,8	B6S	3510		
Buccaneer 12	12			-		0,8	B6S	3510		
Buccaneer 15	15			-		0,8	B6S	3510		
Buccaneer 25	25			-		0,8	B6S	3510		
Buccaneer 35	35			-		0,8	B6S	3510		
Sovereign 35	35			-		0,8	B6S	3510		
Buccaneer 40	40			-		0,8	B6S	3510		
Sovereign 40	40			-		0,8	B6S	3510		
Buccaneer 60	60			-		0,8	B6S	3510		
Sovereign 60	60			-		0,8	B6S	3510		

GARELLI

Gari Jet				-		0,5	B6HS	4510	BR6HIX	3419
----------	--	--	--	---	--	-----	------	------	--------	------



HP

c
m
C
y
l

Stock-No



Stock-NrX

GUAZZONI

Gamberino	4,5			-		0,5	B6S	3510		
-----------	-----	--	--	---	--	-----	------------	-------------	--	--

HANSON MARINE ENGINES

Montana Troller	85			-		0,9	BKR5E	7938	BKR5EIX	6341
-----------------	----	--	--	---	--	-----	--------------	-------------	----------------	-------------

HONDA

BF2A	2		1	-2000	SOHV	0,6	BMR4A	5728		
BF2D	2		1	2001-	-->1026043	0,6	CR5HSB	6535		
BF2D	2		1	1999-	1026044-->	0,6	CR4HSB	4695		
BF20	2		1	1984-1998		0,6	BMR4A	5728		
BF2D2	2	57	1	-		0,7	CR4HSB	4695		
BF2D4	2	57	1	-		0,7	CR4HSB	4695		
BF2.3	2,3		1	-		0,6	CR5HSB	6535		
BF2.3D	2,3		1	2005-		0,6	CR4HSB	4695		
BF2.3D4	2,3	57	1	-		0,7	CR4HSB	4695		
BF2.3DK2	2,3	57	1	-		0,7	CR4HSB	4695		
BF4.5	4,5		1	-		0,7	BPR5ES	7422	BPR5EIX	6597
BF4.5D	4,5		1	-		0,7	BPR5ES	7422	BPR5EIX	6597
BF5	5		1	-		0,7	BPR5ES	7422	BPR5EIX	6597
BF5A	5		1	-	SOHV	0,7	BPR5ES	7422	BPR5EIX	6597
BF5A2	5	127	1	-		0,9	BPR5ES	7422	BPR5EIX	6597
BF5A4	5	127	1	-		0,9	BPR5ES	7422	BPR5EIX	6597
BF5AK2	5	127	1	-		0,9	BPR5ES	7422	BPR5EIX	6597
BF5DK2SB	5	127	1	-		0,9	BPR5ES	7422	BPR5EIX	6597
BF50	5		1	-	SOHV	0,7	BPR5ES	7422	BPR5EIX	6597
BF6	6		1	-		0,6	DR4HS	3326		
BF6CH	6		1	2004-		0,9	CR5EH-9	6689		
B75	7,5		2	1977-	SOHC	0,6	DR5HS	4623		
BF75	7,5		2	1977-	SOHC	0,6	DR5HS	4623		
BF8	8		2	-2000	SOHC	0,6	DR5HS	4623		
BF8	8		2	2001-	SOHC	0,9	CR5EH-9	6689		
BF8A	8		2	-2000	SOHC	0,6	DR5HS	4623		
BF8B1	8		1	-		0,9	CR5EH-9	6689		
BF8C	8		2	-	SOHC	0,6	DR5HS	4623		
BF8D	8		2	2001-	SOHC	0,9	CR5EH-9	6689		
BF8D1	8		2	-	SOHC	0,9	CR5EH-9	6689		
BF8D2	8	222	2	-		0,9	CR5EH-9	6689		
BF8DK2	8	222	2	-		0,9	CR5EH-9	6689		
BFP8D	8		2	2001-	SOHC	0,9	CR5EH-9	6689		
BFP8D1	8		2	2001-	SOHC	0,9	CR5EH-9	6689		
BF100	9,8		2	-	SOHC	0,6	DR5HS	4623		
BF9.9A	9,9		2	-2000	SOHC	0,6	DR5HS	4623		
BF9.9D	9,9		2	2001-	SOHC	0,9	CR5EH-9	6689		
BFP9.9D	9,9		2	2001-	SOHC	0,9	CR5EH-9	6689		
BF100	10			-		0,6	DR5HS	4623		
BF100E	10			-		0,6	DR5HS	4623		
BF10	10			2001-		0,9	CR5EH-9	6689		
BF10B1	10			2001-		0,9	CR5EH-9	6689		
BF10D	10			2001-		0,9	CR5EH-9	6689		



HP







c
c
mC
y
l

Stock-Nº

FRIDUM

Stock-NºX

BF10D2	10	222	2	-		0,9	CR5EH-9	6689		
BF10DK2	10	222	2	-	carbu	0,9	CR5EH-9	6689		
BF10S1	10	222	2	-		0,9	CR5EH-9	6689		
BF100	10		2	-	SOHC	0,6	DR5HS	4623		
BF15A	15		2	-2000	SOHC	0,6	DR6HS	4823		
BF15AX	15	350	2	-		0,7	DR6HS	4823		
BF15D	15		2	2001-	SOHC	0,9	CR5EH-9	6689		
BF15D3	15	350	2	-		0,9	CR5EH-9	6689		
BF15DK2	15	350	2	-		0,9	CR5EH-9	6689		
BFP15D	15		2	2001-	SOHC	0,9	CR5EH-9	6689		
BF20A	20			-		0,7	DR7EA	7839		
BF20A2	20	350	2	-		0,7	DR7EB	5469		
BF20D	20		2	2001-	SOHC	0,9	CR5EH-9	6689		
BF20D3	20	350	2	-		0,9	CR5EH-9	6689		
BF20DK2	20	350	2	-		0,9	CR5EH-9	6689		
BFP20D	20		2	2001-	SOHC	0,9	CR5EH-9	6689		
BF25	25		3	-	SOHC	0,7	DR7EA	7839		
BF25A	25		3	-	SOHC	0,7	DR7EA	7839		
BF25A2	25	499	3	-		0,7	DR7EA	7839		
BF25B	25		3	-	SOHC	0,7	DR7EA	7839		
BF25D	25		3	2004-	SOHC	0,7	DR7EA	7839		
BF25D4	25	552	3	-		0,7	DR7EA	7839		
BF25DK2	25	552	3	-		0,7	DR7EA	7839		
BF30	30		3	-		0,7	DR7EA	7839		
BF30A	30		3	-		0,7	DR7EA	7839		
BF30A2	30	499	3	-		0,7	DR7EA	7839		
BF30D	30		3	2004-		0,7	DR7EA	7839		
BF30D4	30	552	3	-		0,7	DR7EA	7839		
BF30DK2	30	552	3	-		0,7	DR7EA	7839		
BF35	35		3	-		0,7	DR7EA	7839		
BF35A	35		3	1990-		0,7	DR7EA	7839		
BF40	40		3	-		0,7	DR7EA	7839		
BF40A	40		3	1994-		0,7	DR7EA	7839		
BF40A2	40	808	3	-		0,7	DR7EA	7839		
BF40A4	40	808	3	-		0,7	DR7EA	7839		
BF40B	40		3	-		0,7	DR7EA	7839		
BF40D	40		3	-		0,7	DR7EB	5469		
B40DK2	40	808	3	-	PGMFI	0,7	DR7EB	5469		
B45	45		3	1990-		0,6	DR5HS	4623		
BF45	45		3	-		0,7	DR7EA	7839		
BF45A	45		3	-		0,7	DR7EA	7839		
BF50	50		3	-		0,7	DR7EA	7839		
BF50A	50		3	-		0,7	DR7EA	7839		
BF50A2	50	808	3	-		0,7	DR7EA	7839		
BF50A4	50	808	3	-		0,7	DR7EA	7839		
BF50D	50		3	-		0,7	DR7EB	5469		
BF50DK2	50	808	3	-	PGMFI	0,7	DR7EB	5469		
BF50F	50		3	-		0,7	BPR5ES	7422	BPR5EIX	6597
F50	50			-		0,7	DR7EB	5469		
BF60A	60		3	-		0,9	LMAR6A-9	5946		
BF60A	60	998	3	-	EFI		LMAR6C-9	1679		
BFP60A	60		3	-		0,9	LMAR6A-9	5946		
BF60A	60	998	3	-	EFI		LMAR6C-9	1679		

	HP	c c m	C y l					Stock-Nº		Stock-NºX
BF60AK1	60	998	3	-	PGMFI			LMAR6C-9	1679	
BFP60AK1	60	998	3	-	PGMFI			LMAR6C-9	1679	
BF75A	75	1590	4	2003-		0,7		DR7EA	7839	
BF75A2	75	1590	4	-		0,7		DR7EA	7839	
BF75B	75		4	-		0,7		DR7EA	7839	
BF75D	75	1496	4	2006-	VTEC	1,1		IZFR6K11E	6748	
BF75DK	75	1496	4	-		1,1		IZFR6K11E	6748	
BF90A	90	1590	4	1995-		0,7		DR7EA	7839	
BF90A2	90	1590	4	-		0,7		DR7EA	7839	
BF90D	90	1496	4	2006-	VTEC	1,1		IZFR6K11E	6748	
BF90DK2	90	1496	4	-	PGMFI	1,1		IZFR6K11E	6748	
BF115	115		4	-	SOHC	0,8		ZFR7F	5913	
BF115A	115		4	1998-	SOHC	0,8		ZFR7F	5913	
BF115A2	115	2254	4	-	EFI	0,8		ZFR7F-11	2975	
BF115AX	115	2254	4	-	EFI	0,8		ZFR7F	5913	
BF115D	115	2254	4	-	SOHC	1,1		IZFR6K11	6994	
BF115D	115	2254	4	-	EFI	1,1		ZFR6K11	6711	
BF115DK1	115	2254	4	-	PGMFI	1,1		ZFR6K11	6711	
BF115DK1	115	2254	4	-	PGMFI	1,1		IZFR6K11	6994	
BF130	130		4	-		0,8		ZFR7F	5913	
BF130A	130		4	-		0,8		ZFR7F	5913	
BF130A2	130	2254	4	-	EFI	0,8		ZFR7F11	2975	
BF130AX	130	2254	4	-	EFI	0,8		ZFR7F	5913	
BF135	135		4	-	DOHC	1,1		IZFR6K11	6994	
BF135A4	135	2354	4	-	EFI	1,1		IZFR6K11	6994	
BF135AK2	135	2354	4	-	PGMFI	1,1		IZFR6K11	6994	
BF135AK2	135	2354	4	-	PGMFI	1,1		ZFR6K11	6711	
BF150	150		4	-	DOHC	1,1		ZFR6K-11	6711	
BF150A4	150		4	-	EFI	1,1		IZFR6K11	6994	
BF150AK2	150	2354	4	-	PGMFI	1,1		IZFR6K11	6994	
BF150AK2	150	2354	4	-	PGMFI	1,1		ZFR6K11	6711	
BF175A3	175	3471	6	-	EFI	1,1		IZFR6K11	6994	
BF175A3	175	3471	6	-	EFI	1,1		IZFR6F11	4095	
BF175A6	175	3471	6	-	EFI	1,1		IZFR6K11	6994	
BF175A6	175	3471	6	-	EFI	1,1		IZFR6F11	4095	
BF175AK1	175	3471	6	-	EFI	1,1		IZFR6K11	6994	
BF175AK1	175	3471	6	-	EFI	1,1		IZFR6F11	4095	
BF175AK2	175	3471	6	-	PGMFI	1,1		IZFR6K11	6994	
BF175AK2	175	3471	6	-	PGMFI	1,1		IZFR6F11	4095	
BF200	200		4	-	DOHC	1,1		IZFR6F11	4095	
BF200A	200			2002-		1,1		IZFR6F11	4095	
BF200A2	200	3471	6	-	EFI	1,1		IZFR6F11	4095	
BF200A6	200	3471	6	-	EFI	1,1		IZFR6F11	4095	
BF200AK1	200	3471	6	-	EFI	1,1		IZFR6F11	4095	
BF200AK2	200	3471	6	-	PGMFI	1,1		IZFR6F11	4095	
BF220	220		4	-	SOHC	1,1		IZFR6F11	4095	
BF225	225		4	-	SOHC	1,1		IZFR6F11	4095	
BF225A	225		6	2002-		1,1		IZFR6F11	4095	
BF225A2	225	3471	6	-	EFI	1,1		IZFR6F11	4095	
BF225A6	225	3471	6	-	EFI	1,1		IZFR6F11	4095	
BF225AK1	225	3471	6	-	EFI	1,1		IZFR6F11	4095	
BF225AK2	225	3471	6	-	PGMFI	1,1		IZFR6F11	4095	
BF250A	250	3583	6	-	PGMFI	1,1		IZFR6F11	4095	



HP

c
mC
y
l

Stock-Nº



Stock-NºX

BF250A	250	3583	6	-	PGMFI	1,1	ZFR6K-11E	94001		
--------	-----	------	---	---	-------	-----	-----------	-------	--	--

HUSQVARNA

All models				-		0,5	B6HS	4510	BR6HIX	3419
------------	--	--	--	---	--	-----	------	------	--------	------

ITALMARINE





920 25 SIL	70			-		1,0	BZ7HS-10	3579		
920 25 SITL	70			-		1,0	BZ7HS-10	3579		
Ocean Runner V6	150		6	-		-	BUZHW	2147		
Ocean Runner V6	175		6	-		-	BUZHW	2147		
Ocean Runner V6	200		6	-		1,0	BZ7HS-10	3579		
Ocean Runner V6	225		6	-		1,0	BZ7HS-10	3579		
Ocean Runner V6	250		6	-		1,0	BZ7HS-10	3579		

J.L.O.

Aquascooter				-		0,5	B6HS	4510	BR6HIX	3419
L-35				-		0,5	B6HS	4510	BR6HIX	3419

JOHNSON

Air Bouy Diving Unit				1966-1970		0,6	BM4A	5628		
1R	1			1968-1970		0,8	B6S	3510		
Magneto	1,2			1986-1990		0,8	B6S	3510		
SC	1,5			1968-1968		0,8	B6S	3510		
2R	2			1971-1984		0,8	B6S	3510		
Aquanaut Diving Unit	2			1966-1970		0,8	BM4A	5628		
Colt Jr	2			1971-1990		0,8	B6S	3510		
Excel 4	2			1987-1988		0,8	B7HS	5110	BR7HIX	7067
Ultra	2			1987-1988		0,8	B7HS	5110	BR7HIX	7067
JH	3			1954-1968		0,8	B6S	3510		
JHF	3			1967-1968		0,8	B6S	3510		
JWF	3			1967-1968		0,8	B6S	3510		
JW	3			1952-1968		0,8	B6S	3510		
Lightwin	3	2		1952-1974		0,8	B6S	3510		
4R	4			1969-1976		0,8	B6S	3510		
4W	4			1969-1976		0,8	B6S	3510		
Excel	4			1987-1988		0,8	BZ7HS-10	3579		
Ultra	4			1987-1988		0,8	BZ7HS-10	3579		
V4	4			1958-1967		0,8	B6S	3510		
V4A	4			1958-1967		0,8	B6S	3510		
V4M	4			1958-1967		0,8	B6S	3510		
V4S	4			1958-1967		0,8	B6S	3510		
VX	4			1958-1967		0,8	B6S	3510		
VXH	4			1958-1967		0,8	B6S	3510		
LD	5			1965-1968		0,8	B6S	3510		
TN	5			1952-1966		0,8	B6S	3510		
Angler	5			1965-1968		0,8	B6S	3510		
Lightwin	5,2	2		1952-1974		0,8	B6S	3510		
CD	5,5			1954-1964		0,8	B6S	3510		
CD	6			1965-1968		0,8	B6S	3510		

	HP	c c m	C y l					Stock-Nr	TRUBUM	Stock-NrX		
6R	6			1971 - 1976				0,8	B6S	3510		
6RL	6			1971 - 1976				0,8	B6S	3510		
RLSRS	6			2004-				0,8	BR6HS	3922	BR6HIX	3419
RSRS	6			2004-				0,8	BR6HS	3922	BR6HIX	3419
COM	6,5			1981 - 1993				0,8	BR6HS	3922	BR6HIX	3419
AD	7,5			1956 - 1958				0,8	B6S	3510		
COM	8			1977 - 2001				0,8	BR6HS	3922	BR6HIX	3419
RLSRC	8			2004-				0,8	BR6HS	3922	BR6HIX	3419
RSRC	8			2004-				0,8	BR6HS	3922	BR6HIX	3419
9R	9			1974-				0,8	BZ7HS-10	3579		
9RL	9			1974-				0,8	BZ7HS-10	3579		
9EL	9			1974-				0,8	BZ7HS-10	3579		
MQ	9,5			1964 - 1968				0,8	B6S	3510		
QD	10			1949 - 1963				0,8	B6S	3510		
10E	10			1975 - 1976				0,8	BZ7HS-10	3579		
10EL	10			1975 - 1976				0,8	BZ7HS-10	3579		
10E	10			1977 - 1979				-	BUHW-2	5626		
10R	10			1977 - 1979				-	BUHW-2	5626		
10SEL	10			1977 - 1979				-	BUHW-2	5626		
10R	10			1975 - 1976				0,8	BZ7HS-10	3579		
10RL	10			1975 - 1976				0,8	BZ7HS-10	3579		
COM	10			1981 - 1982				-	BUHW-2	5626		
COM	10			1992 - 1993				0,8	BZ7HS-10	3579		
COM	10			1994 - 2002				0,8	BR7HS	4122	BR7HIX	7067
EL4SOR	10			2005-				0,8	BKR6ES	3783	BKR6EIX	6418
R4SOA	10			2005-				0,8	BKR6ES	3783	BKR6EIX	6418
L4SOA	10			2005-				0,8	BKR6ES	3783	BKR6EIX	6418
TBL4SOB	10			2005-				0,8	BKR6ES	3783	BKR6EIX	6418
TE4SOA	10			2005-				0,8	BKR6ES	3783	BKR6EIX	6418
TEL4SOA	10			2005-				0,8	BKR6ES	3783	BKR6EIX	6418
EL4SRC	10			2004-				0,9	DCPR6E	3481	DCPR6EIX	8196
R4SR	10			2004-				0,9	DCPR6E	3481	DCPR6EIX	8196
RL4SR	10			2004-				0,9	DCPR6E	3481	DCPR6EIX	8196
RBL4SR	10			2004-				0,9	DCPR6E	3481	DCPR6EIX	8196
RE4SR	10			2004-				0,9	DCPR6E	3481	DCPR6EIX	8196
TEL4SR	10			2004-				0,9	DCPR6E	3481	DCPR6EIX	8196
R4STC	10			2003-				0,9	DCPR6E	3481	DCPR6EIX	8196
BL4STS	10			2003-				0,9	DCPR6E	3481	DCPR6EIX	8196
LE4STS	10			2003-				0,9	DCPR6E	3481	DCPR6EIX	8196
L4STC	10			2003-				0,9	DCPR6E	3481	DCPR6EIX	8196
BL4STC	10			2003-				0,9	DCPR6E	3481	DCPR6EIX	8196
RE4STC	10			2003-				0,9	DCPR6E	3481	DCPR6EIX	8196
TEL4STC	10			2003-				0,9	DCPR6E	3481	DCPR6EIX	8196
RHLSOR	10			2005-				0,8	BR7HS	4122	BR7HIX	7067
RHSOR	10			2005-				0,8	BR7HS	4122	BR7HIX	7067
RLSOS	10			2005-				0,8	BR7HS	4122	BR7HIX	7067
RSOS	10			2005-				0,8	BR7HS	4122	BR7HIX	7067
RHLSRC	10			2004-				0,8	BR7HS	4122	BR7HIX	7067
RHSRC	10			2004-				0,8	BR7HS	4122	BR7HIX	7067
RLSRD	10			2004-				0,8	BR7HS	4122	BR7HIX	7067
RSRD	10			2004-				0,8	BR7HS	4122	BR7HIX	7067
RHLSTS	10			2003-				0,8	BR7HS	4122	BR7HIX	7067
RHSTS	10			2003-				0,8	BR7HS	4122	BR7HIX	7067



HP







c
c
mC
y
l

Stock-Nr

FRIBUM

Stock-NrX

RLSTE	10		2003-		0,8	BR7HS	4122	BR7HIX	7067
RSTE	10		2003-		0,8	BR7HS	4122	BR7HIX	7067
COM	14		1981-1991		0,8	BZ7HS-10	3579		
Fastwin	14	2	1950-1972		0,8	B6S	3510		
15E	15		1974-1976		0,8	BZ7HS-10	3579		
15EL	15		1974-1976		0,8	BZ7HS-10	3579		
15R	15		1974-1976		0,8	BZ7HS-10	3579		
15RL	15		1974-1976		0,8	BZ7HS-10	3579		
COM	15		1992-1993		0,8	BZ7HS-10	3579		
COM	15		1994-2001		0,8	BR7HS	4122	BR7HIX	7067
Kero	15		1995-1998		-	BUHXW-1	5526		
L4SR	15		2004-		0,9	DCPR6E	3481	DCPR6EIX	8196
R4SR	15		2004-		0,9	DCPR6E	3481	DCPR6EIX	8196
TE4SR	15		2004-		0,9	DCPR6E	3481	DCPR6EIX	8196
TEL4SR	15		2004-		0,9	DCPR6E	3481	DCPR6EIX	8196
LSRS	15		2004-		0,8	BR7HS	4122	BR7HIX	7067
RSRS	15		2004-		0,8	BR7HS	4122	BR7HIX	7067
WRLSRM	15		2004-		0,8	BR7HS	4122	BR7HIX	7067
WRSRM	15		2004-		0,8	BR7HS	4122	BR7HIX	7067
FD	18		1956-1965		0,8	B6S	3510		
FDE	18		1956-1968		0,8	B6S	3510		
Fastwin	18	2	1950-1972		0,8	B6S	3510		
Fastwin	18	2	1957-1973		0,8	B8S	3810		
Jet 2	18		1974-1994		0,8	BR6HS	3922	BR6HIX	3419
Jet	18	2	1995-1998		0,8	BR7HS	4122	BR7HIX	7067
FD	20		1966-1968		0,8	B6S	3510		
20R	20		1973-		0,8	B6S	3510		
20RL	20		1973-		0,8	B6S	3510		
20R	20		1969-1972		0,8	B6S	3510		
25R	20		1969-1972		0,8	B6S	3510		
20RL	20		1971-1972		0,8	B6S	3510		
25RL	20		1971-1972		0,8	B6S	3510		
Jet	20	2	1999-2001		0,8	BR7HS	4122	BR7HIX	7067
RD	25		1951-1955		0,8	B6S	3510		
RDE	25		1954-1955		0,8	B6S	3510		
20R	25		1969-1972		0,8	B6S	3510		
25R	25		1969-1972		0,8	B6S	3510		
25E	25		1973-1976		0,8	B6S	3510		
25EL	25		1973-1976		0,8	B6S	3510		
25R	25		1973-1976		0,8	B6S	3510		
25RL	25		1973-1976		0,8	B6S	3510		
25E	25		1977-1978		-	BUHW-2	5626		
25EL	25		1977-1978		-	BUHW-2	5626		
25R	25		1977-1978		-	BUHW-2	5626		
COM	25		1981-2002		-	BUHXW-1	5526		
RX	28		1962-1964		0,8	B6S	3510		
RXE	28		1963-1964		0,8	B6S	3510		
28 Jet	28		1992-2003		0,8	BPZ8HS-10	3133		
RD	30		1956-1956		0,8	B6S	3510		
RDE	30		1956-1956		0,8	B6S	3510		
RJE	30		1956-1956		0,8	B6S	3510		
Jet	30	2	1999-2001		0,8	BPR7HS	6422	BPR7HIX	5944
RX	33		1965-1968		0,8	B6S	3510		

	HP	c m	C y l					Stock-Nº		Stock-NºX
RXE	33			1965-1968		0,8	B6S	3510		
RD	35			1957-1958		0,8	B6S	3510		
RDE	35			1957-1958		0,8	B6S	3510		
RDS	35			1958-1959		0,8	B6S	3510		
RJE	35			1957-1957		0,8	B6S	3510		
Jet	35		2	1993-2003		0,8	BPZ8HS-10	3133		
RD	40			1958-1968		0,8	B6S	3510		
RDS	40			1960-1968		0,8	B6S	3510		
RK	40			1962-1968		0,8	B6S	3510		
Jet	40		3	1999-2001		0,8	BPR7HS	6422	BPR7HIX	5944
40E	40			1969-1973		0,8	B6S	3510		
40EL	40			1969-1973		0,8	B6S	3510		
40R	40			1969-1973		0,8	B6S	3510		
40RL	40			1969-1973		0,8	B6S	3510		
40E	40			1974-1976		0,8	BZ7HS-10	3579		
40EL	40			1974-1976		0,8	BZ7HS-10	3579		
40R	40			1974-1976		0,8	BZ7HS-10	3579		
40RL	40			1974-1976		0,8	BZ7HS-10	3579		
COM	40			1984-1990		-	BUHW-2	5626		
COM	40			1981-1990	43 cid	0,8	B7HS	5110	BR7HIX	7067
COM	40			1984-2003	45 cid	-	BUHXW-1	5526		
PL4SRM	40			2004-		0,9	DCPR6E	3481	DCPR6EIX	8196
PL4SRS	40			2004-		0,9	DCPR6E	3481	DCPR6EIX	8196
PLSRS	40			2004-		0,8	BZ7HS-10	3579		
RLSRS	40			2004-		0,8	BZ7HS-10	3579		
RSRS	40			2004-		0,8	BZ7HS-10	3579		
COM	45			1984-2002		-	BUHXW-1	5526		
PL4STC	50			2003-		0,9	DCPR6E	3481	DCPR6EIX	8196
PL4SRS	50			2004-		0,9	DCPR6E	3481	DCPR6EIX	8196
PL4SRM	50			2004-		0,9	DCPR6E	3481	DCPR6EIX	8196
PLSRS	50			2004-		0,8	BZ7HS-10	3579		
PLSTD	50			2003-		0,8	BZ7HS-10	3579		
Sizzler	50			1971-1975		0,8	B7HS	5110	BR7HIX	7067
COM	55			1986-2005		-	BUHXW-1	5526		
COM	55		2	1994-1995		0,8	BPZ8HS-10	3133		
Triumph	60		3	1970-1971		-	BUHW	2622		
V4	60			1964-1967		0,8	B6S	3510		
65 Jet CV4	65			1992-1997		0,8	BR7HS	4122	BR7HIX	7067
COM	65		3	1994-1995		0,8	BPZ8HS-10	3133		
COM HC LC	65			1984-1987		0,8	BZ7HS-10	3579		
COM HC LC	65			1988-2003		-	BUHXW-1	5526		
V4 Sportfour	65		4	1968-		0,8	BZ7HS-10	3579		
V4H	75			1964-1966		0,8	B6S	3510		
V4	75			1960-1965		0,8	B6S	3510		
80 Jet CV4	80			1979-2001		0,8	BR7HS	4122	BR7HIX	7067
Starfire	80		4	1966-1967		0,8	B8S	3810		
V4 Backtroller	85		4	1994-1995		0,8	BR7HS	4122	BR7HIX	7067
CV4 SPL	88			1979-1997		0,8	BR7HS	4122	BR7HIX	7067
Carburetor	90			2001-2002		0,8	BZ7HS-10	3579		
CV4	90			1979-1998		0,8	BR7HS	4122	BR7HIX	7067
LV4	90			1995-2000		0,8	BPZ8HS-10	3133		
LV4 F.F.I.	90			1998-		0,8	PZFR6H	7696		
Turbojet CV4	90			1994-1998		0,8	BR7HS	4122	BR7HIX	7067



HP







c
mC
y
l

Stock-Nr



Stock-NrX

GLSOB	90		2005-		0,8	BKR6ES	3783	BKR6EIX	6418
PX4SOR	90		2005-		0,8	BKR6ES	3783	BKR6EIX	6418
GLSRM	90		2004-		0,8	BZ7HS-10	3579		
PLSRR	90		2004-		0,8	BZ7HS-10	3579		
PXSRS	90		2004-		0,8	BZ7HS-10	3579		
GLSTA	90		2003-		0,8	BZ7HS-10	3579		
PLSTC	90		2003-		0,8	BZ7HS-10	3579		
PL4SOR	90		2005-		0,8	BZ7HS-10	3579		
PLSOA	90		2005-		0,8	BZ7HS-10	3579		
PXSOC	90		2005-		0,8	BZ7HS-10	3579		
PL4SRC	90		2004-		0,8	BKR6ES	3783	BKR6EIX	6418
PX4SRC	90		2004-		0,8	BKR6ES	3783	BKR6EIX	6418
PL4SRC	90		2004-		0,8	BKR6ES	3783	BKR6EIX	6418
PX4SRC	90		2004-		0,8	BKR6ES	3783	BKR6EIX	6418
PL4STC	90		2003-		0,8	BKR6ES	3783	BKR6EIX	6418
PX4STC	90		2003-		0,8	BKR6ES	3783	BKR6EIX	6418
PL4STC	90		2003-		0,8	BKR6ES	3783	BKR6EIX	6418
PX4STC	90		2003-		0,8	BKR6ES	3783	BKR6EIX	6418
V4ML	100		1966-1966		0,8	B6S	3510		
COM	100		1984-2001		-	BUHXW-1	5526		
CV4	100	4	1979-1997		0,8	BR6HS	3922	BR6HIX	3419
Starfire	100	4	1967-1972		0,8	B7HS	5110	BR7HIX	7067
V4	100		1979-1980		0,8	B7HS	5110	BR7HIX	7067
COM LV4	105		1997-2003		0,8	BPZ8HS-10	3133		
LV6 105 Jet	105	6	1993-2003		0,8	BPZ8HS-10	3133		
CV4	110		1979-1997		0,8	BR7HS	4122	BR7HIX	7067
CV4	112	4	1979-1997		0,8	BR7HS	4122	BR7HIX	7067
COM	115		1975-1984		0,8	B7HS	5110	BR7HIX	7067
CV4	115		1979-1998		0,8	BR7HS	4122	BR7HIX	7067
Fast Strike LV4	115	4	1995-2002		0,8	BPZ8HS-10	3133		
GLSOB	115		2005-		0,8	BPZ8HS-10	3133		
PLSOR	115		2005-		0,8	BPZ8HS-10	3133		
PXSOR	115		2005-		0,8	BPZ8HS-10	3133		
WPLSOC	115		2005-		0,8	BPZ8HS-10	3133		
GLSRC	115		2004-		0,8	BPZ8HS-10	3133		
PLSRC	115		2004-		0,8	BPZ8HS-10	3133		
PXSRM	115		2004-		0,8	BPZ8HS-10	3133		
WPLSRS	115		2004-		0,8	BPZ8HS-10	3133		
GLSTA	115		2003-		0,8	BPZ8HS-10	3133		
PLSTS	115		2003-		0,8	BPZ8HS-10	3133		
PXSTS	115		2003-		0,8	BPZ8HS-10	3133		
L4SRC	115		2004-		0,8	BKR6ES	3783	BKR6EIX	6418
5X4SRC	115		2004-		0,8	BKR6ES	3783	BKR6EIX	6418
PL4SRC	115		2004-		0,8	BKR6ES	3783	BKR6EIX	6418
PX4SRC	115		2004-		0,8	BKR6ES	3783	BKR6EIX	6418
L4STS	115		2003-		0,8	BKR6ES	3783	BKR6EIX	6418
X4STS	115		2003-		0,8	BKR6ES	3783	BKR6EIX	6418
PL4STS	115		2003-		0,8	BKR6ES	3783	BKR6EIX	6418
PX4STS	115		2003-		0,8	BKR6ES	3783	BKR6EIX	6418
LV4 F.F.I.	115		1998-		0,8	PZFR6H	7696		
PL450R	115		2005-		0,8	BKR6ES	3783	BKR6EIX	6418
PX450R	115		2005-		0,8	BKR6ES	3783	BKR6EIX	6418
Turbojet CV4	115		1994-1998		0,8	BR7HS	4122	BR7HIX	7067

	HP	c c m	C y l					Stock-Nº		Stock-NºX
X-115	115			1967-1968		-	BUHW	2622		
LV4	120			1985-2003		0,8	BPZ8HS-10	3133		
125 COM	125			1971-1972		0,8	B7HS	5110	BR7HIX	7067
LV4	130			1985-2003		0,8	BPZ8HS-10	3133		
Starflite	135			1973-1984		-	BUHXW-1	5526		
LV4	140			1985-2002		0,8	BPZ8HS-10	3133		
Carb.	150			2002-		0,8	BPZ8HS-10	3133		
CV6	150		6	1978-1987		-	BUHXW-1	5526		
CV6	150		6	1988-1991		0,8	BZ7HS-10	3579		
COM LV6	150		6	1993-1998		0,8	BPZ8HS-10	3133		
Fast Strike LV6	150		6	1991-2001		0,8	BPZ8HS-10	3133		
LV6 F.F.I.	150		6	1997-1998		0,8	PZFR6H	7696		
CV6	155		6	1978-1987		-	BUZ8H	7447		
COM CV6	155		6	1989-1992		-	BUZ8H	7447		
CV6	175		6	1988-1991		0,8	BZ7HS-10	3579		
Fast Strike LV6	175		6	1991-2002		0,8	BPZ8HS-10	3133		
LV6 F.F.I.	175		6	1998-		0,8	PZFR6H	7696		
COM	200			1992-		-	BUZ8H	7447		
COM	200			1993-1998		0,8	BPZ8HS-10	3133		
LV6 DI	200		6	2004-		0,8	PZFR6H	7696		
V6	200		6	1986-1993		0,8	BZ7HS-10	3579		
Venom LV6	200		6	1994-2003		0,8	BPZ8HS-10	3133		
LV6 DI	225		6	2004-		0,8	PZFR6H	7696		
V6	225		6	1986-1993		0,8	BZ7HS-10	3579		
Venom LV6	225		6	1994-2001		0,8	BPZ8HS-10	3133		
LV6	250		6	1999-2001		-	BUHXW-1	5526		
LV6 Fict	250		6	2000-2003		0,8	PZFR6H	7696		
V8	250		8	1985-1997		0,8	BPZ8HS-10	3133		
V8	300		8	1985-1997		0,8	BPZ8HS-10	3133		
LAURA										
Boatmaster				-		0,5	B6HS	4510	BR6HIX	3419
Boatmaster	Forte acceleration			-		0,8	BR6HS	3922	BR6HIX	3419
LEHR										
LP 2.5S	2,5	72		-	Propane, OHV	0,6	BR6HS	3922	BR6HIX	3419
LP 5.0L	5	112		-	Propane, OHV	0,6	BR6HS	3922	BR6HIX	3419
LP 5.0S	5	112		-	Propane, OHV	0,6	BR6HS	3922	BR6HIX	3419
MARINEPOWER										
Seapro Marathon	10			-		1,5	BP8HS-15	6729		
Seapro Marathon	15			-		1,5	BP8HS-15	6729		
Seapro Marathon	75			-		-	BUZHW-2	2173		
Optimax	75			2004-		0,8	PZFR6H	7696		
Optimax	90			2004-		0,8	PZFR6H	7696		
Optimax	115			-2000		1,1	PZFR5F-11	4363		
Optimax	115			2004-		0,8	PZFR6H	7696		
Optimax	135			-		1,1	PZFR5F-11	4363		
Optimax	150			-		1,1	PZFR5F-11	4363		
Optimax	175			-		1,1	PZFR5F-11	4363		



HP

c
c
mC
y
l

Stock-Nr





FRIBUM

Stock-NrX

Optimax	200			-		1,1	PZFR5F-11	4363		
210 Jetdrive	210			-		0,8	BUZ8H	7447		
Sport Jet 175XR2	210			-		0,8	BUZ8H	7447		
Optimax	225			-		1,1	PZFR5F-11	4363		
Jetdrive	240			-		1,0	BPZ8HS-10	3133		

MARINER

2A 646	2			-		0,6	B6HS	4510	BR6HIX	3419
2B 6A1	2			-	-->M-011600	0,6	B6HS	4510	BR6HIX	3419
2B 6A1	2			-	M-011601-->	0,6	B5HS	4210		
Carb.	2,5		1	-		0,9	DCPR6E	3481	DCPR6EIX	8196
642	3,5			-	-->ML-41690	0,6	B7HS	5110	BR7HIX	7067
642	3,5			-	ML-41691-->	0,6	B6HS	4510	BR6HIX	3419
642	3,5			-	>M-23740	0,6	B7HS	5110	BR7HIX	7067
642	3,5			-	M-23741-->	0,6	B6HS	4510	BR6HIX	3419
Carb.	3,5		1	-		0,9	DCPR6E	3481	DCPR6EIX	8196
4A 6E0	4			-		0,6	B7HS	5110	BR7HIX	7067
5A 661	5			-		0,6	B7HS	5110	BR7HIX	7067
5B 661	5			-		0,6	B7HS	5110	BR7HIX	7067
5C 6E3	5			-		0,6	B7HS	5110	BR7HIX	7067
6B 678	6			-		0,6	B5HS	4210		
6C 6H8	6			-		0,8	B7HS-10	2129		
6D 6H6	6			-		0,8	B7HS-10	2129		
8.0 Bodensee	8			1995-1999		0,7	CR6HS	7023	CR6HIX	7274
8A 647	8			-		0,6	B6HS	4510	BR6HIX	3419
8A 655	8			-		0,6	B6HS	4510	BR6HIX	3419
8B 677	8			-		0,6	B7HS	5110	BR7HIX	7067
8C 6G1	8			-		0,8	B7HS-10	2129		
K8 680	8			1991-2000		0,6	B6HS	4510	BR6HIX	3419
Marathon 8 677	8			-		0,6	B7HS	5110	BR7HIX	7067
W8 677	8			-		0,6	B7HS	5110	BR7HIX	7067
9.9	9,9			1999-2002		0,9	DPR6EA-9	5531		
9.9	9,9		2	-		0,9	DCPR6E	3481	DCPR6EIX	8196
9.9C 682	9,9			-		0,6	B7HS	5110	BR7HIX	7067
9.9C 682	9,9			-	CDI	0,8	B7HS-10	2129		
Big Foot	9,9			1995-2002		0,7	CR6HS	7023	CR6HIX	7274
Sail Power	9,9			1995-2002		0,7	CR6HS	7023	CR6HIX	7274
Magnum	10			1991-1998		1,5	BP8HS-15	6729		
Marathon	10			1991-2002		1,5	BP8HS-15	6729		
Bigfoot	15			1998-		0,9	DPR6EA-9	5531		
15A 651	15			-		0,6	B7HS	5110	BR7HIX	7067
15C 684	15			-		0,6	B7HS	5110	BR7HIX	7067
15C 684	15			-	CDI	0,8	B7HS-10	2129		
K15 669	15			-		0,6	B6HS	4510	BR6HIX	3419
K15 6K4	15			1984-2000		0,8	B7HS-10	2129		
K15 6M7	15			-		0,8	B7HS-10	2129		
Marathon	15			1992-1996		1,0	BP8H-N-10	4838		
Marathon	15			1997-2002		1,5	BP8HS-15	6729		
Marathon 684	15			-		0,6	B7HS	5110	BR7HIX	7067
Marathon 684	15			-	CDI	0,9	B7HS-10	2129		
W15 662	15			-		0,6	B7HS	5110	BR7HIX	7067
W15 684	15			-		0,9	B7HS-10	2129		

	HP	c cm	C y l					Stock-Nr	FRIBUM	Stock-NrX
196										
20A 653	20			-		0,6	B6HS	4510	BR6HIX	3419
20C 6A9	20			-		0,6	B7HS	5110	BR7HIX	7067
Jet	20			1995-2001		1,0	BP8H-N-10	4838		
25A 648	25			-		0,6	B7HS	5110	BR7HIX	7067
25B 690	25			-		0,6	B7HS	5110	BR7HIX	7067
25C 695	25			-		0,6	B7HS	5110	BR7HIX	7067
K25 6A4	25			1997-2000		0,6	B7HS	5110	BR7HIX	7067
Marathon	25			1993-2002		1,0	BP8H-N-10	4838		
Marathon 648	25			-		0,6	B7HS	5110	BR7HIX	7067
Marathon 694	25			-		0,6	B7HS	5110	BR7HIX	7067
Marathon 695	25			-		0,6	B7HS	5110	BR7HIX	7067
W25 648	25			-		0,6	B7HS	5110	BR7HIX	7067
W25 694	25			-		0,6	B7HS	5110	BR7HIX	7067
W25 695	25			-		0,6	B7HS	5110	BR7HIX	7067
664	28			-		0,6	B7HS	5110	BR7HIX	7067
30A 689	30			1992-1994		0,6	B7HS	5110	BR7HIX	7067
BigFoot	30		3	1999-	EFI	0,9	DPR6EA-9	5531		
Jet	30		3	1995-1997		-	BUHW-2	5626		
Jet	30		3	1998-2001		1,0	BP8H-N-10	4838		
Marathon	30			1995-2002		1,0	BP8H-N-10	4838		
Marathon 698B	30			-		0,6	B7HS	5110	BR7HIX	7067
W30 689A	30			1992-1993		0,6	B7HS	5110	BR7HIX	7067
W30 689B	30			1992-1993		0,6	B7HS	5110	BR7HIX	7067
40A 676A	40			-		0,6	BR8HS	4322	BR8HIX	7001
40B 675B	40			-		0,6	B8HS	5510	BR8HIX	7001
40C 6E9	40			1981-1994		0,6	B8HS	5510	BR8HIX	7001
A 676A	40			-		0,6	B8HS	5510	BR8HIX	7001
K406F5	40		2	1984-2000		0,6	B7HS	5110	BR7HIX	7067
Marathon	40		2	1995-2002		1,0	BP8H-N-10	4838		
Marathon 6F6	40			1985-1994		0,6	B7HS	5110	BR7HIX	7067
W40 6F6	40			-		0,6	B7HS	5110	BR7HIX	7067
W40 676A	40			-		0,6	B8HS	5510	BR8HIX	7001
Jet	45		3	1995-2001		1,0	BP8H-N-10	4838		
Bodensee	45		4	1995-1998		0,9	DPR6EA9	5531		
670	48			-		0,6	B7HS	5110	BR7HIX	7067
W48 670	48			-		0,6	B7HS	5110	BR7HIX	7067
M55 663	55			-	--> EL-315378	0,6	B8HS	5510	BR8HIX	7001
M55 663	55			-	EL-315379-->	0,9	B8HS-10	5126		
M55 663	55			-	--> E-004040	0,6	B8HS	5510	BR8HIX	7001
M55 663	55			-	E-004041-->	0,9	B8HS-10	5126		
Marathon	55			1991-2002		1,0	BP8H-N-10	4838		
Marathon 55 663	55			-		0,6	B8HS	5510	BR8HIX	7001
W55 663	55			-		0,6	B8HS	5510	BR8HIX	7001
6F0	60			-		0,9	B8HS-10	5126		
675	60			-	-->L-302050	0,6	B8HS	5510	BR8HIX	7001
675	60			-	L-302051-->	0,9	B8HS-10	5126		
675	60			-	-->S-000780	0,6	B8HS	5510	BR8HIX	7001
675	60			-	S-000781-->	0,9	B8HS-10	5126		
Big Foot	60			1995-1999		1,0	BP8H-N-10	4838		
Marathon	60			1995-2002		1,0	BP8H-N-10	4838		
Jet	65			1995-2001		-	BUHW-2	5626		
469										



HP

c
mC
y
l

Stock-Nº

FRIBUM

Stock-NºX

Marathon	75			1991-2002		-	BUHW-2	5626		
80 Jet	80			1995-2001		1,0	BP8H-N-10	4838		
Jet	105		6	1995-1999		-	BU8H	6431		
115 Optimax	115			2000-2004		1,0	PZFR5F-11	4363		
Marathon	135			1986-1999		-	BU8H	6431		
Optimax	135			1998-2002		1,0	PZFR5F-11	4363		
Verado	135		4	-		0,7	ILFR6G	5588		
Work	135			1986-1993		-	BU8H	6431		
Jet	140			1995-1999		-	BU8H	6431		
Magnum	150			-		-	BU8H	6431		
Magnum II	150			1988-1991		-	BU8H	6431		
Magnum III	150			1992-1997		-	BU8H	6431		
Magnum	150			1993-1997	EFI	-	BU8H	6431		
Optimax	150			1997-2002		1,0	PZFR5F-11	4363		
Verado	150		4	-		0,7	ILFR6G	5588		
Work	150			-		-	BU8H	6431		
Magnum	175			1991-1997	EFI	-	BU8H	6431		
Ski	175			1989-1994		-	BU8H	6431		
Verado	175		4	-		0,7	ILFR6G	5588		
Magnum	200			1989-1997	EFI	-	BU8H	6431		
Optimax	200			1997-2004		1,0	PZFR5F-11	4363		
Super Magnum	200			1997-	EFI	-	BU8H	6431		
Verado	200		6	-		0,7	ILFR6G	5588		
Magnum	220			1987-1988	EFI	-	BU8H	6431		
Marathon	225	3000		1997-2001		0,9	BR8HS	4322	BR8HIX	7001
Optimax	225			1998-2004		1,0	PZFR5F-11	4363		
Super Magnum	225			1997-	EFI	-	BU8H	6431		
Verado	225		6	-		0,7	ILFR6G	5588		
Magnum	250			1996-2001	EFI	0,9	BR8HS	4322	BR8HIX	7001
Pro Verado	250		6	-		0,7	ILFR6G-E	4212		
Verado	250		6	-		0,7	ILFR6G	5588		
275	275	3400		1991-1994		-	BU8H	6431		
275 Verado	275		6	-		0,7	ILFR6G	5588		
Drag	300	2500	6	1997-1998	EFI	-	BUZHW	2147		
Super Magnum	300	3000		1997-1998	EFI	0,8	BZ7HS-10	3579		
Pro Verado	300		6	-		0,7	ILFR6G-E	4212		
Verado	300		6	-		0,7	ILFR6G-E	4212		
MARTIN				-						
20	2			-		0,9	B6S	3510		
40	4,5			-		0,9	B6S	3510		
45	4,5			-		0,9	B6S	3510		
60	7,2			-		0,9	B6S	3510		
66	7,2			-		0,9	B6S	3510		
75	7,5			-		0,9	B6S	3510		
100	10			-		0,9	B6S	3510		

MCCULLOCH

590				-		0,9	B6S	3510		
630				-		0,9	B6S	3510		
Arbre long	4			1964-1969		0,8	B-6L	3212		



HP

c
mC
y
l

Stock-No

TRIDIUM

Stock-NrX

MEDINA

All Models				-		0,8	B6HS	4510	BR6HIX	3419
------------	--	--	--	---	--	-----	------	------	--------	------

MERCURY

F1 Carb		2000		-	EFI	-	BUHW	2622		
Bass		2400		-		-	BUHW	2622		
Mod VP		2400		-		-	BUHW	2622		
Carb		2500		1991-1993		-	BUHW	2622		
10X				-		1,0	BP8HS-10	3823		
25SS Racing		21,9		-		-	BUHW	2622		
25SS				-		-	BUHW-2	5626		
25XS				-		-	BUHW	2622		
44XS				-		-	BUHW-2	5626		
650X Racing		49,9		-		-	BUHW	2622		
Twister 11-X Racing		99,9		-		-	BUHW	2622		
SST 140				-		-	BUHW	2622		
XR-2 Magnum				-		-	BUHW	2622		
Classic	2,5		1	1993-2005		1,0	BP6HS-10	6326		
Classic	4		1	1988-2006		1,0	BPR7HS-10	1092		
40 Gnat	4		1	1976-1979		0,8	BR6HS	3922	BR6HIX	3419
Classic	5		1	1988-2006		1,0	BPR7HS-10	1092		
8.0 Bodensee	8		2	1995-2002		0,7	CR6HS	7023	CR6HIX	7274
100	9,8		2	1960-1961		0,6	B6S	3510		
110	9,8		2	1962-1966		0,6	B6S	3510		
110	9,8		2	1967-1969		0,8	B7HS	5110	BR7HIX	7067
110	9,8		2	1970-1973		-	BUHW-2	5626		
110	9,8		2	1974-		-	BUHW	2622		
110	9,8		2	1975-1978		-	BUHW-2	5626		
Bigfoot	9,9		2	2001-2011		0,9	DCPR6E	3481	DCPR6EIX	8196
Prockicker	9,9		2	2001-2011		0,9	DCPR6E	3481	DCPR6EIX	8196
10 Sea Pro	10		2	1991-2000		1,5	BP8HS-15	6729		
10 Sea Pro	10		2	2001-2002		1,5	BPZ8HS-15	3180		
XR10	10		2	1992-1998		1,5	BP8HS-15	6729		
150	15		2	1960-1961		0,6	B6S	3510		
Bigfoot	15		2	1998-2006		0,9	DPR6EA-9	5531		
Bigfoot	15		2	2007-2011		0,9	DCPR6E	3481	DCPR6EIX	8196
Prockicker	15		2	2007-2011		0,9	DCPR6E	3481	DCPR6EIX	8196
Sea Pro	15		2	1995-1996		1,0	BP8HS-10	3823		
Sea Pro	15		2	1997-2000		1,5	BP8HS-15	6729		
Sea Pro	15		2	2001-2002		1,5	BPZ8HS-15	3180		
18 XD	18		2	1984-1985		1,0	BP8H-N-10	4838		
200	20		2	1960-1961		0,6	B6S	3510		
200	20		2	1963-1966		0,6	B6S	3510		
200	20		2	1967-1969		0,8	B7HS	5110	BR7HIX	7067
200	20		2	1970-1978		-	BUHW-2	5626		
Jet	20		2	1995-2000		1,0	BP8H-N-10	4838		
Jet	20		2	2001-2002		1,0	BPZ8H-N-10	4495		
Sea Pro	20		2	2001-		1,0	BPZ8H-N-10	4495		
25	25		3	2006-2011	EFI	0,9	DCPR6E	3481	DCPR6EIX	8196
25 XD	25			1984-1985		1,0	BP8H-N-10	4838		
250	25			1962-		0,6	B6S	3510		



HP







c
mC
y
l

Stock-Nr

IZFRUM

Stock-NrX

Sea Pro	25			1993-2002		1,0	BP8H-N-10	4838		
30	30	526	3	1999-2011	EFI	0,9	DPR6EA-9	5531		
300	30		4	1960-		0,6	B6S	3510		
Jet	30		2	2001-2002		1,0	BPZ8H-N-10	4495		
Jet	30		3	1998-2001		1,0	BP8H-N-10	4838		
SeaPro	30		2	1995-2000		1,0	BP8H-N-10	4838		
SeaPro	30		2	2001-2002		1,0	BPZ8H-N-10	4495		
350	35			1961-1966		0,6	B7S	3710		
350	35			1963-1965		0,6	B6S	3510		
350	35			1967-1969		0,8	B7HS	5110	BR7HIX	7067
350	35		4	1961-		0,6	B6S	3510		
SeaPro	40		2	1995-2000		1,0	BP8H-N-10	4838		
SeaPro	40		2	2001-2006		1,0	BPZ8H-N-10	4495		
BigFoot	40		4	2001-2006		0,9	DPR6EA9	5531		
Bigfoot	40	995	4	2007-2011	EFI	0,9	DCPR6E	3481	DCPR6EIX	8196
400	40			1960-1961		0,6	B6S	3510		
400	40			1970-1971		-	BUHW	2622		
402	40			1972-1978		-	BUHW	2622		
450	45			1962-		0,6	B6S	3510		
Bodensee	45		4	1995-2002		0,9	DPR6EA9	5531		
Jet	45		3	1995-2000		1,0	BP8H-N-10	4838		
Jet	45		3	2001-2002		1,0	BPZ8H-N-10	4495		
Bigfoot	50		4	1995-2001		0,9	DPR6EA9	5531		
Bigfoot	50	995	4	2006-2011		0,9	DCPR6E	3481	DCPR6EIX	8196
500	50			1961-1964		0,6	B6S	3510		
500	50			1965-1966		0,6	B7S	3710		
500	50			1968-1977		-	BUHW	2622		
500	50			1978-		-	BUHW-2	5626		
500M	50			1967-		0,8	B7HS	5110	BR7HIX	7067
500S	50			1967-		0,8	B7HS	5110	BR7HIX	7067
500SS	50			1967-		-	BUHW	2622		
SeaPro	55		3	1992-2000		1,0	BP8H-N-10	4838		
SeaPro	55		3	2001-2006		1,0	BPZ8H-N-10	4495		
SeaPro	60		3	1995-2000		1,0	BP8H-N-10	4838		
SeaPro	60		3	2001-2002		1,0	BPZ8H-N-10	4495		
BigFoot	60	995	4	2001-2011		0,9	DCPR6E	3481	DCPR6EIX	8196
600	60		6	1960-		0,6	B6S	3510		
60	60			1984-1990		-	BUHW	2622		
Big Foot	60			1995-2002		1,0	BP8H-N-10	4838		
Jet	60			-		-	BUZHW-2	2173		
650	65			1963-1966		0,6	B7S	3710		
650	65			1972-1976		-	BUHW	2622		
650S	65			1967-		0,8	B7HS	5110	BR7HIX	7067
650S	65			1968-1971		-	BUHW	2622		
650SS	65			1967-1971		-	BUH	2422		
Jet	65		3	1995-2000		-	BUHW-2	5626		
Jet	65		3	2001-2002		-	BUZHW-2	2173		
700	70			1960-1961		0,6	B6S	3510		
700	70			1977-1978		-	BUHW	2622		
Jet	75		3	2001-		-	BUZHW-2	2173		
SeaPro	75		3	1991-2001		-	BUHW-2	5626		
Optimax	75	1500	3	2003-2011		0,8	IZFR5J	5899		
75XD	75		4	1984-1986			BUHW2	5626		

	HP	c c m	C y l					Stock-No		Stock-NrX
Walleye	75			2007-			0,8	LFR4A-E	6499	
Jet	80		4	1995-2000			1,0	BP8HN10	4838	
Jet	80		4	2001-			1,0	BPZ8HN10	4495	
800	80			1969-			-	BUHW	2622	
800	80			1970-1972			-	BUHW	2622	
800	80			1978-			-	BUHW-2	5626	
800	80		6	1960-1961			0,6	B7S	3710	
850	85			1973-1977			-	BUHW	2622	
850	85		6	1962-1964			0,6	B7S	3710	
Optimax	90	1500	3	2003-2011			0,8	IZFR5J	5899	
900	90			1965-			0,6	B7S	3710	
900	90			1978-			-	BUHW	2622	
Walleye	90			2007-			0,8	LFR4A-E	6499	
950	95			1966-			0,8	B7HS	5110	BR7HIX 7067
950SS	95			1966-1967			-	BUHW	2622	
100	100			1988-1999			1,0	BP8H-N-10	4838	
1000	100			1962-1964			0,6	B7S	3710	
1000BP	100			1968-1969			-	BUHW	2622	
1000SS	100			1968-1969			-	BUHW	2622	
105 Jet	105			1995-1998			-	BU8H	6431	
1100	110			1966-			0,8	B7HS	5110	BR7HIX 7067
1100SS	110			1966-1967			-	BUHW	2622	
Optimax Pro XS	115	1500	3	2006-2011			0,8	IZFR5J	5899	
1150	115			1970-1978			-	BUHW	2622	
Optimax	115			2006-			0,8	IZFR5J	5899	
Optimax	115		6	2000-2002			1,0	PZFR5F-11	4363	
Optimax	115		6	2003-2004			0,8	IZFR5G	5887	
Walleye	115			2007-			0,8	LFR4A-E	6499	
Optimax	125		3	2010-2011			0,8	IZFR5J	5899	
1250BP	125			1968-1969			-	BUHW	2622	
1250SS	125			1968-1969			-	BUHW	2622	
1350	135			1970-1971			-	BUHW	2622	
Optimax	135		6	1996-2001	DFI		1,0	PZFR5F-11	4363	
Optimax	135		6	2003-2006	DFI		0,8	IZFR5G	5887	
140	140			1979-1980			-	BUHW	2622	
140 Jet	140			1995-1999			-	BU8H	6431	
1400	140			1972-1978			-	BUHW	2622	
1400	140			1970-1978			-	BUHW	2622	
150 Magnum Pro Max Super	150			-			-	BUHW	2622	
150	150			1979-1984			-	BU8H	6431	
150	150			2000-2006			1,0	BPZ8HS-10	3133	
150	150			1998-1999	EFI		-	BU8H	6431	
150	150		6	2000-2006	EFI		1,0	BPZ8HS-10	3133	
150	150		6	2006-	Supercharged, EFI		0,8	ILFR6G	5588	
150	150		6	2006-	EFI		0,8	ILFR6G-E	4212	
150 Marathon	150			1985-1988			-	BU8H	6431	
150 Optimax	150		6	1996-2002	DFI		1,0	PZFR5F-11	4363	
150 Optimax	150		6	2003-2006	DFI		0,8	IZFR5G	5887	
150 Optimax Pro XS	150	2500	6	2003-2011			0,8	IZFR5G	5887	
150 Verado	150	1700	4	2006-2011			1,1			LFR5AIX-11 4469
150 XR-2	150			1985-2002			-	BU8H	6431	
150 XR-4	150			1985-2002			-	BU8H	6431	
150 XR-6	150			1992-1997			-	BU8H	6431	



HP

c
c
mC
y
l

Stock-No

FRIDIUM

Stock-NoX

150 XRi	150			1993-2002		-	BU8H	6431		
1500	150			1973-1977		-	BUHW	2622		
1500	150			1978-		-	BU8H	6431		
175	175			1998-1999	EFI	-	BU8H	6431		
175	175		6	2006-	Supercharged, EFI	0,8	ILFR6G	5588		
175	175		6	2006-	Supercharged, EFI	0,8	ILFR6G-E	4212		
175	175		6	2000-2001	EFI MFI	1,0	BPZ8HS-10	3133		
175 Verado	175	1700	4	2005-2011	EFI	0,8	ILFR6GE	4212		
175 Optimax	175		6	2001-2002	DFI	1,0	PZFR5F-11	4363		
175 Optimax	175		6	2003-2006	DFI	0,8	IZFR5G	5887		
175 Optimax Pro XS	175		6	2003-2011		0,8	IZFR5G	5887		
175 XRi	175			1991-2002		-	BU8H	6431		
200 Magnum Pro Max Super	200			-	EFI	-	BUHW	2622		
Duece High	200	2000		1997-	EFI	-	BUZ8H	7447		
F1	200	2000		1997-	EFI	-	BUZHW	2147		
SST 120	200	2000		1997-	EFI	-	BUHW	2622		
XR2 SS	200	2000		1997-	EFI	-	BUHW	2622		
200	200			1979-1999		-	BU8H	6431		
200	200			1997-	DFI	1,0	PZFR6H	7696		
200	200			1998-1999	EFI	-	BU8H	6431		
200	200			2006-	EFI	0,8	ILFR6G	5588		
200	200		6	2006-	EFI	1,0	BR8HS	4322	BR8HIX	7001
200	200		6	2000-2006	EFI MFI	1,0	BPZ8HS-10	3133		
200 Optimax	200		6	1996-2002		1,0	PZFR5F-11	4363		
200 Optimax	200		6	2003-2006		0,8	IZFR5G	5887		
200 Optimax XS	200		6	2002-2004		1,0	PZFR5F-11	4363		
200 Optimax XS	200	2500		2000-2004		1,0	PZFR5F-11	4363		
200 Optimax XS	200	3000		2000-2004		1,0	PZFR5F-11	4363		
200 Verado	200		4	-		0,8	ILFR6GE	4212		
200 Verado	200		6	2004-		0,8	ILFR6G	5588		
200 Verado	200		6	2004-		0,8	ILFR6G-E	4212		
200 XRi	200			1989-2002		-	BUZ8H	7447		
2000	200			1978-		-	BUHW	2622		
2V-220 Laser	220			1987-1988		-	BUZ8H	7447		
225 Magnum Pro Max Super	225			-	EFI	-	BUHW	2622		
3.0L SeaPro	225	3000	6	1997-2002		0,9	BR8HS	4322	BR8HIX	7001
Work	225	3000		1994-1997		1,0	BPZ8H-N-10	4495		
Work	225	3000		1998-		0,9	BR8HS	4322	BR8HIX	7001
225	225			1980-1981		-	BU8H	6431		
225	225		6	2006-	Supercharged, EFI	0,8	ILFR6G	5588		
225	225		6	2006-	EFI	0,8	ILFR6G-E	4212		
225	225		6	1995-2006	EFI DFI	0,9	BR8HS	4322	BR8HIX	7001
225	225		6	2006-	EFI DFI	1,1	LF5A-11	6376	LF5AIX-11	4469
225 Optimax	225		6	1996-2004		1,0	PZFR5F-11	4363		
225 Optimax	225		6	2006-		0,8	IZFR5G	5887		
225 Optimax Pro XS	225	3000	6	2005-2011		0,8	IZFR5G	5887		
225 Optimax XS	225		6	2003-2004		0,8	IZFR6J	4462		
225 Xri	225			1995-2002	EFI	0,9	BR8HS	4322	BR8HIX	7001
225 Verado	225		6	2004-		0,8	ILFR6G	5588		
225 Verado	225		6	2004-		0,8	ILFR6G-E	4212		
250	250	3400		1989-1990		-	BU8H	6431		
250	250		6	2006-	Supercharged, EFI	0,8	ILFR6G	5588		
250	250		6	2006-	Supercharged, EFI	0,8	ILFR6G-E	4212		

	HP	cc m	C y l					Stock-N°		Stock-N°X
250 Verado	250		6	2004-			0,8	ILFR6G	5588	
250 Verado	250		6	2004-			0,8	ILFR6G-E	4212	
250 Xri	250		6	1995-2006	EFI		0,9	BR8HS	4322	BR8HIX 7001
250 Optimax XS	250		6	2003-2006			0,8	IZFR6J	4462	
Offshore	260	2500		1995-1997			-	BU8H	6431	
SS Drag	265	2500		1997-	EFI		-	BU8H	6431	
275	275			1989-1994			-	BU8H	6431	
275	275		6	2006-	Supercharged, EFI		0,8	ILFR6G	5588	
275	275		6	2006-	Supercharged, EFI		0,8	ILFR6G-E	4212	
275 Verado	275		6	2004-			0,8	ILFR6G	5588	
275 Verado	275		6	2004-			0,8	ILFR6G-E	4212	
Sport	280	2500		2002-	EFI		0,8	BZ7HS-10	3579	
SS	280	2500		2002-	EFI		0,8	BZ7HS-10	3579	
Offshore	280	2500		2002-			0,8	BZ7HS-10	3579	
S3000	300	2500		1997-	EFI		-	BU8H	6431	
300	300			1981-1983			-	BU8H	6431	
300 Optimax XS	300	3200	6	2006-2011	EFI		0,8	IZFR5J	5899	
300 Verado	300		6	-			0,8	ILFR6G-E	4212	
300 Verado Pro	300	2600	6	2008-2011			1,1			LFR5AIX-11 4469
350 Verado SCI	350		6	-			0,8	ILFR6G-E	4212	
MID-JET										
M-2				-			0,8	BR6S	3522	
M-3				-			0,8	BR6S	3522	
M-4				-			0,8	BR6HS	3922	BR6HIX 3419
MINI MOTOR (K&P)										
Aqua Bug				1972-1973			0,8	BM4A	5628	
Aqua Bug II				1973-			0,6	BMR6F	2144	
Mini Engine				1969-1973			0,8	BM4A	5628	
MONO										
M-5A				-			0,8	B6S	3510	
M-6A				-			0,8	B6S	3510	
M-50				-			0,8	B6S	3510	
M-75				-			0,8	BP5S	3011	
MOSKVA										
Moskva-25	25			-			0,8	BP6HS	4511	BPR6HIX 4085
Moskva-30D	30			-			0,8	BP6ES	7811	BPR6EIX 6637
MOTO ATTREZZI										
Mac 10				-			0,6	BR6HS	3922	BR6HIX 3419
NAUTILO										
75	3			-			0,5	B6HS	4510	BR6HIX 3419
100	5			-			0,5	B6HS	4510	BR6HIX 3419



HP

c
mC
y
l







Stock-Nº

FRIDUM

Stock-NºX

NEPTUNE

11A12				-		0,6	AB-6	2910		
17AA1A				-		0,6	BGS	3510		
101				-		0,6	BGS	3510		
104				-		0,6	BGS	3510		
106				-		0,6	BGS	3510		
111				-		0,6	B-4	3210		
113				-		0,6	BGS	3510		
114				-		0,6	BGS	3510		
116				-		0,6	BGS	3510		
139				-		0,6	BGS	3510		
189				-		0,6	BGS	3510		
238				-		0,6	AB-6	2910		
239				-		0,6	AB-6	2910		
438				-		0,6	AB-6	2910		
439				-		0,6	AB-6	2910		
539				-		0,6	BGS	3510		
639				-		0,6	AB-6	2910		
938				-		0,6	BGS	3510		
939				-		0,6	BGS	3510		
1010				-		0,6	BGS	3510		
1016				-		0,6	AB-6	2910		
1110				-		0,6	BGS	3510		
1638				-		0,6	AB-6	2910		
1639				-		0,6	AB-6	2910		
A2				-		0,6	BGS	3510		
AA2				-		0,6	BGS	3510		
AA4				-		0,6	BGS	3510		
AA6				-		0,6	BGS	3510		
AA10				-		0,6	BGS	3510		
OB102				-		0,6	AB-6	2910		
OB112				-		0,6	AB-6	2910		
1A39	1,5		1	1939-		0,6	BGS	3510		
10A1	1,5		1	1940-		0,6	BGS	3510		
11A1	1,5		1	1941-		0,6	B-4	3210		
15A1	1,5		1	1945-		0,6	B-4	3210		
17A1	1,5		1	1947-		0,6	BGS	3510		
17AA1	1,5		1	1947-		0,6	BGS	3510		
OB1	2		1	1933-		0,6	AB-6	2910		
OB11	2		1	1936-		0,6	AB-6	2910		
OB12	2		1	1937-		0,6	AB-6	2910		
17A2	2,5		1	1947-		0,6	BGS	3510		
OB2	2,5		2	1931-		0,6	AB-6	2910		
OB2C	2,5		2	1931-		0,6	AB-6	2910		
OB31	3		2	1933-		0,6	AB-6	2910		
11A3	3,5		2	1941-		0,6	BGS	3510		
11AA3	3,5		2	1941-		0,6	BGS	3510		
15A3	3,5		2	1945-		0,6	BGS	3510		
15AA3	3,5		2	1945-		0,6	BGS	3510		
17A3	3,5		2	1947-		0,6	BGS	3510		
4A39	4		2	1939-		0,6	BGS	3510		
10A4	4		2	1940-		0,6	BGS	3510		

	HP	c cm	C y l					Stock-Nº		Stock-NºX		
OB3	4		2	1932-				0,6	AB-6	2910		
OB4	4		2	1933-				0,6	AB-6	2910		
OB32	4		2	1935-				0,6	AB-6	2910		
OB34	4		2	1936-				0,6	AB-6	2910		
5A39	5		2	1939-				0,6	B6S	3510		
10A6	6		2	1940-				0,6	B6S	3510		
11A6	6		2	1941-				0,6	B6S	3510		
11AA6	6		2	1941-				0,6	B6S	3510		
15A6	6		2	1945-				0,6	B6S	3510		
15AA6	6		2	1945-				0,6	B6S	3510		
OB51	6		2	1933-				0,6	AB-6	2910		
OB63	6		2	1935-				0,6	AB-6	2910		
OB64	6		2	1936-				0,6	AB-6	2910		
OB65	6		2	1936-				0,6	AB-6	2910		
9A39	9		2	1939-				0,6	B6S	3510		
10A10	9,5		2	1940-				0,6	B6S	3510		
11A10	9,5		2	1941-				0,6	B6S	3510		
15A9	9,5		2	1945-				0,6	B6S	3510		
15AA9	9,5		2	1945-				0,6	B6S	3510		
10A16	16		2	1940-				0,6	AB-6	2910		
11A16	16		2	1941-				0,6	AB-6	2910		
16A39	16		2	1939-				0,6	AB-6	2910		

NISSAN

NSF 2.0A	2		1	2007-				0,6	DCPR6E	3481	DCPR6EIX	8196
NS 2.5A	2,5		1	1985-1996				1,0	BP6HS-10	6326		
NS 2.5A	2,5		1	1997-2007				1,0	BPR6HS-10	2633		
NS 2.5A2	2,5		1	-				1,0	BP6HS-10	6326		
NSF 2.5B	2,5		1	-				0,6	DCPR6E	3481	DCPR6EIX	8196
NS 3.5A	3,5		1	1985-1992				1,0	BP6HS-10	6326		
NS 3.5A	3,5		1	1997-2006				1,0	BPR6HS-10	2633		
NS 3.5A2	3,5		1	2007-				1,0	BPR6HS-10	2633		
NS 3.5B	3,5		1	1993-1996				1,0	BP6HS-10	6326		
NS 3.5B	3,5		1	1997-2007				1,0	BPR6HS-10	2633		
NS 3.5B2	3,5		1	-				1,0	BPR6HS-10	2633		
NSF 3.5A	3,5		1	2007-				0,6	DCPR6E	3481	DCPR6EIX	8196
NSF 3.5B	3,5		1	-				0,6	DCPR6E	3481	DCPR6EIX	8196
NSF 4	4		1	2007-2008				0,6	DCPR6E	3481	DCPR6EIX	8196
NSF 4A	4		1	2000-2008				0,6	DCPR6E	3481	DCPR6EIX	8196
NSF 4A2	4		1	-				0,6	DCPR6E	3481	DCPR6EIX	8196
NSF 4B	4		1	-				0,6	DCPR6E	3481	DCPR6EIX	8196
NS 5	5		1	1985-1996				1,0	BP7HS-10	7829		
NS 5B	5		1	1997-2008				1,0	BPR7HS-10	1092		
NS 5BS	5		1	-				1,0	BPR7HS-10	1092		
NSF 5	5		1	2007-2008				0,6	DCPR6E	3481	DCPR6EIX	8196
NSF 5A	5		1	1999-2008				0,6	DCPR6E	3481	DCPR6EIX	8196
NSF 5A2	5		1	-				0,6	DCPR6E	3481	DCPR6EIX	8196
NSF 5B	5		1	-				0,6	DCPR6E	3481	DCPR6EIX	8196
NSF 5C	5		1	-				0,6	DCPR6E	3481	DCPR6EIX	8196
NSF 6	6		1	2007-2008				0,6	DCPR6E	3481	DCPR6EIX	8196
NSF 6A	6		1	2004-2007				0,6	DCPR6E	3481	DCPR6EIX	8196
NSF 6A2	6		1	-				0,6	DCPR6E	3481	DCPR6EIX	8196



HP







c
mC
Y
I

Stock-Nr

FRIBUM

Stock-NrX

NSF 6B	6		1	-		0,6	DCPR6E	3481	DCPR6EIX	8196
NSF 6C	6		1	-		0,6	DCPR6E	3481	DCPR6EIX	8196
NS 8A	8		2	1985-1986		1,0	BP7HS-10	7829		
NS 8B	8		2	1987-1996		1,0	BP7HS-10	7829		
NS 8B	8		2	1997-2007		1,0	BPR7HS-10	1092		
NSF 8A	8		2	2004-2008		1,0	DCPR6E	3481	DCPR6EIX	8196
NSF 8A3	8		2	-		1,0	DCPR6E	3481	DCPR6EIX	8196
NS 9.8B	9,8		2	1998-2008		1,0	BPR7HS-10	1092		
NSF 9.8A	9,8		2	2007-		0,6	DCPR6E	3481	DCPR6EIX	8196
NSF 9.8A3	9,8		2	-		0,6	DCPR6E	3481	DCPR6EIX	8196
NS 9.9B	9,9		2	1985-1996		1,0	B7HS-10	2129		
NS 9.9B	9,9		2	1997-2007		1,0	BR7HS-10	1098		
NS 9.9C	9,9		2	2004-2008		1,0	B7HS-10	2129		
NS 9.9D	9,9		2	2004-2007		1,0	B7HS-10	2129		
NS 9.9D2	9,9		2	-		1,0	BP7HS-10	7829		
NSF 9.9A	9,9		2	2000-2008		0,6	DCPR6E	3481	DCPR6EIX	8196
NSF 9.9B	9,9		2	2004-2008		0,6	DCPR6E	3481	DCPR6EIX	8196
NSF 9.9B2	9,9		2	-		0,6	DCPR6E	3481	DCPR6EIX	8196
NS 12	12		2	1985-1987		1,0	B7HS-10	2129		
NS 12	12		2	1994-		1,0	B7HS-10	2129		
NS 12C	12		2	2004-2007		1,0	BR7HS-10	1098		
NS 15B	15		2	1985-1992		1,0	B7HS-10	2129		
NS 15B	15		2	2004-2007		1,0	BR7HS-10	1098		
NS 15C	15		2	1993-1996		1,0	BP7HS-10	7829		
NS 15C	15		2	1997-1999		1,0	BPR7HS-10	1092		
NS 15C	15		2	2004-2007		1,0	B7HS-10	2129		
NS 15D	15		2	2000-2001		0,8	BPR7HS-10	1092		
NS 15D	15		2	2004-2007		1,0	BR7HS-10	1098		
NS 15D	15		2	-		1,0	B7HS-10	2129		
NSF 15A	15		2	2004-2008		0,6	DCPR6E	3481	DCPR6EIX	8196
NSF 15B	15		2	2004-2008		0,6	DCPR6E	3481	DCPR6EIX	8196
NSF 15B2	15		2	-		0,6	DCPR6E	3481	DCPR6EIX	8196
NSF 15C	15		2	-		0,6	DCPR6E	3481	DCPR6EIX	8196
NS 18	18		2	1993-1996		1,0	B7HS-10	2129		
NS 18	18		2	1997-1999		1,0	BR7HS-10	1098		
NS 18C	18		2	1985-1992		1,0	B7HS-10	2129		
NS 18C	18		2	2004-2007		1,0	B7HS-10	2129		
NS 18D	18		2	2004-2008		1,0	B7HS-10	2129		
NS 18E	18		2	2000-2001		0,8	BPR7HS-10	1092		
NS 18E	18		2	2004-2007		1,0	BR7HS-10	1098		
NS 18E2	18		2	-		1,0	B7HS-10	2129		
NSF 18B	18		2	2004-2008		0,6	DCPR6E	3481	DCPR6EIX	8196
NSF 18B2	18		2	2004-2008		0,6	DCPR6E	3481	DCPR6EIX	8196
NS F20C	20		2	-		0,6	DCPR6E	3481	DCPR6EIX	8196
NS 25	25			1986-1996		1,0	B7HS-10	2129		
NS 25C	25		2	1997-2007		0,8	BR7HS-10	1098		
NS 25C3	25		2	-		1,0	B7HS-10	2129		
NSF 25A	25		3	2004-2008		0,6	DCPR6E	3481	DCPR6EIX	8196
NSF 25B	25		3	2007-2008		0,6	DCPR6E	3481	DCPR6EIX	8196
NS 30A	30		2	1986-1996		1,0	B7HS-10	2129		
NS 30A	30		2	1997-2007		1,0	BR7HS-10	1098		
NS 30A4	30		2	-		1,0	B7HS-10	2129		
NSF 30A	30		3	2004-2008		0,6	DCPR6E	3481	DCPR6EIX	8196

	HP	c c m	C y l					Stock-Nº		Stock-NºX
NSF 30B	30		3	2007-2008		0,6	DCPR6E	3481	DCPR6EIX	8196
NS 35C	35			1994-1995		1,0	B7HS-10	2129		
NSD 40A	40		3	2004-2008	TLDI	1,1	ZFR6F-11	4291	ZFR6FIX-11	6441
NSD 40B	40		3	2004-2008	TLDI	0,8	PZFR6H	7696		
NS 40C	40		2	2004-2007		1,0	BR7HS-10	1098		
NS 40D	40		3	1997-2006		0,8	BR7HS-10	1098		
NS 40D	40		3	2007-2008		1,0	B7HS-10	2129		
NS 40D2	40		3	2007-		0,8	BR7HS-10	1098		
NS 40C	40		2	1985-1992		1,0	B7HS-10	2129		
NS 40D	40		3	1991-1996		1,0	B7HS-10	2129		
NS 40D2	40		3	-		1,0	B7HS-10	2129		
NSD 40B2	40		3	-	TLDI	0,8	IZFR6Q	91234		
NS 45A	45			1994-1995		1,0	B8HS-10	5126		
NS 50D	50		3	1997-2006		1,0	BR8HS-10	1134		
NS 50D	50		3	2007-2008		1,0	B8HS-10	5126		
NS 50D2	50		3	2007-		1,0	BR8HS-10	1134		
NS 50C	50		2	1985-1992		1,0	B8HS-10	5126		
NS 50D	50		3	1991-1996		1,0	B8HS-10	5126		
NSD 50A	50		3	2004-2008	TLDI	1,1	ZFR6F-11	4291	ZFR6FIX-11	6441
NSD 50B	50		3	2004-2008	TLDI	0,8	PZFR6H	7696		
NSD 50B2	50		3	-	TLDI	0,8	IZFR6Q	91234		
W50B	50			2004-2008	TLDI	0,8	PZFR6H	7696		
NS 55	60			1985-1986		1,0	B8HS-10	5126		
NS 60B	60		3	1993-1995		1,0	B8HS-10	5126		
NS 60A	60		2	1987-1992		1,0	B8HS-10	5126		
NS 60B	60		3	2004-2007		1,0	B8HS-10	5126		
NS 60C	60		3	2004-2007		1,0	BR8HS-10	1134		
NSD 70A	70		3	2004-2008	TLDI	1,1	ZFR6F-11	4291	ZFR6FIX-11	6441
NSD 70A2	70		3	-	TLDI	1,1	ZFR6F-11	4291	ZFR6FIX-11	6441
NSD 70B	70		3	2004-2006	TLDI	0,8	PZFR6H	7696		
NSD 70B	70		3	2007-	TLDI	1,1	PZFR6F-11	3271		
NS 70B	70		3	1997-1999		1,0	BR8HS-10	1134		
NS 70C	70		3	2000-2007		1,0	BR8HS-10	1134		
NS 70A	70		2	-		1,0	B8HS-10	5126		
NS 70B	70		3	1986-1996		1,0	B8HS-10	5126		
NS 70B	70		3	2004-2007		1,0	B8HS-10	5126		
NSD 75C2	75		3	-	TLDI	0,8	IZFR6Q	91234		
NSD 90A	90		3	2004-2007	TLDI	1,1	ZFR6F-11	4291	ZFR6FIX-11	6441
NSD 90A2	90		3	-	TLDI	1,1	ZFR6F-11	4291	ZFR6FIX-11	6441
NSD 90B	90		3	2004-2006	TLDI	0,8	PZFR6H	7696		
NSD 90B	90		3	2007-	TLDI	1,1	PZFR6F-11	3271		
NSD90C2	90		3	-		0,8	IZFR6Q	91234		
NS 90A	90		3	1987-1996		1,0	B8HS-10	5126		
NS 90A	90		3	1997-2007		1,0	BR8HS-10	1134		
1NSD 115A	115		4	2007-2008	TLDI	0,8	IZFR5J	5899		
1NSD 115A2	115		4	-	TLDI	0,8	IZFR5J	5899		
1NS 120A	120		4	1990-1996		1,0	B8HS-10	5126		
1NS 120A	120		4	1997-2007		1,0	BR8HS-10	1134		
1NS 140A	140		4	1990-1996		1,0	B8HS-10	5126		
1NS 140A2	140		4	1997-2006		1,0	BR8HS-10	1134		



HP

c
m
C
y
l

Stock-Nº

FRIDUM

Stock-NºX

OTTERBINE

Jet Drive	2			-		0,6	BR2-LM	5798		
-----------	---	--	--	---	--	-----	---------------	-------------	--	--

OUTBOARD JET

J55	5,5			-		0,8	BR6S	3522		
J55B	5,5			-		0,8	BR6S	3522		

OUTBOARD MARINE

1.8L Sea Drive		1800		1984-1992		1,0	BZ7HS-10	3579		
2.0L Sea Drive		2000		1990-1992		1,0	BZ7HS-10	3579		
2.5L Sea Drive		2500		1981-		-	BUZHW	2147		
2.6L Sea Drive		2600		1981-1983		-	BUZHW	2147		
2.6L Sea Drive		2600		1984-1990		1,0	BZ7HS-10	3579		
2.7L Sea Drive		2700		1984-1990		1,0	BZ7HS-10	3579		
3.0L Sea Drive		3000		1990-1992		1,0	BZ7HS-10	3579		
3.6L Sea Drive		3600		1984-1990		1,0	BZ7HS-10	3579		
4.0L Sea Drive		4000		1990-1991		1,0	BZ7HS-10	3579		
1AA				1981-1983		-	BUZHW	2147		
1AB				1981-1983		-	BUZHW	2147		
1.6L Sea Drive	110	1600		1984-1992		1,0	BZ7HS-10	3579		
1.6L Sea Drive	110	1600		1983-1983		-	BUZHW	2147		

PEERLESS

J5				-		0,8	BM4A	5628		
J9				-		0,8	BR6S	3522		

SCOTT (McCulloch)





Sports Scott	12			1959-1960		0,9	BR6S	3522		
Fleet	14			1962-1963		0,9	BR6S	3522		
Power Scott	14			1962-1963		0,9	BR6S	3522		
Sports Scott	14,1			1961-		0,9	BR6S	3522		
Sports Scott	25			1959-1960		0,9	BR6S	3522		
Sports Scott	27,1			1961-		0,9	BR6S	3522		
Sports Scott	28			1962-1963		0,9	BR6S	3522		
Sports Scott	40			1959-1960		0,9	BR6S	3522		
Sports Scott	43,7			-		0,9	BR6S	3522		
Royal Scott	45			1962-1963		0,9	BR6S	3522		
Sports Scott	60			1959-1960		0,9	BR6S	3522		
Flying Scott	75			1962-1963		0,9	BR6S	3522		
Custom	75,2			1961-		0,9	BR6S	3522		

SEA-BEE

All Models				1946-		0,9	BR6S	3522		
------------	--	--	--	-------	--	-----	-------------	-------------	--	--

SEARS

585120	1,2			-		0,6	BR6S	3522		
--------	-----	--	--	---	--	-----	-------------	-------------	--	--

	HP	c cm	C y l					Stock-Nº	FRIDIUM	Stock-NºX		
585121	1,2			-				0,6	BR6S	3522		
585122	1,2			-				0,6	BMR6A	7421		
58241	2			-				0,8	B-4	3210		
58250	2			-				0,8	B-4	3210		
58540	3			-				0,8	XR5	3332	XR5IX	7355
58541	3			-				0,8	XR5	3332	XR5IX	7355
58543	3			-				0,8	XR5	3332	XR5IX	7355
58544	3			-				0,8	XR5	3332	XR5IX	7355
585210	3			-				0,8	XR5	3332	XR5IX	7355
585211	3			-				0,8	XR5	3332	XR5IX	7355
585220	3			-				0,8	XR5	3332	XR5IX	7355
6003	3,5			-				0,8	B-6L	3212		
6091	3,5			-				0,8	BM6A	5921		
6094	3,5			-				0,8	BM6A	5921		
58510	3,5			-				0,9	B6S	3510		
58542	3,5			-				0,9	XR5	3332	XR5IX	7355
58550	3,5			-				0,9	XR5	3332	XR5IX	7355
58560	3,5			-				0,9	XR5	3332	XR5IX	7355
59501	3,5			-				0,8	BM6A	5921		
59860	3,5			-				0,9	B6S	3510		
59861	3,5			-				0,9	B6S	3510		
59862	3,5			-				0,9	XR5	3332	XR5IX	7355
59900	3,5			-				0,8	BM6A	5921		
60020	3,5			-				0,8	B-6L	3212		
60030	3,5			-				0,8	B-6L	3212		
585230	3,5			-				0,8	XR5	3332	XR5IX	7355
585240	3,5			-				0,8	XR5	3332	XR5IX	7355
585241	3,5			-				0,8	XR5	3332	XR5IX	7355
585280	3,5			-				0,8	XR5	3332	XR5IX	7355
6001	3,6			-				0,8	B-6L	3212		
58511	3,6			-				0,9	B6S	3510		
58512	3,6			-				0,9	B6S	3510		
58513	3,6			-				0,9	XR5	3332	XR5IX	7355
58514	3,6			-				0,9	XR5	3332	XR5IX	7355
60000	3,6			-				0,8	B-6L	3212		
58580	4			-				0,8	XR5	3332	XR5IX	7355
585270	4			-				0,8	XR5	3332	XR5IX	7355
59460	4,5			-				0,9	XR5	3332	XR5IX	7355
59461	4,5			-				0,9	XR5	3332	XR5IX	7355
59462	4,5			-				0,9	XR5	3332	XR5IX	7355
59463	4,5			-				0,9	XR5	3332	XR5IX	7355
59464	4,5			-				0,9	XR5	3332	XR5IX	7355
58970	4,8			-				0,9	XR5	3332	XR5IX	7355
58971	4,8			-				0,9	XR5	3332	XR5IX	7355
58520	5			-				0,9	B6S	3510		
58521	5			-				0,9	XR5	3332	XR5IX	7355
58610	5			-				0,9	XR5	3332	XR5IX	7355
58620	5			-				0,9	XR5	3332	XR5IX	7355
58960	5			-				0,9	B6S	3510		
58961	5			-				0,9	B6S	3510		
58962	5			-				0,9	XR5	3332	XR5IX	7355
58990	5			-				0,9	XR5	3332	XR5IX	7355
58991	5			-				0,9	XR5	3332	XR5IX	7355



HP





c
c
mC
y
l

Stock-Nr

FRIBUM

Stock-NrX

58992	5			-		0,9	XR5	3332	XR5IX	7355
59310	5			-		0,9	XR5	3332	XR5IX	7355
59311	5			-		0,9	XR5	3332	XR5IX	7355
59520	5			-		0,9	B6S	3510		
59670	5			-		0,9	B6S	3510		
59671	5			-		0,9	B6S	3510		
59672	5			-		0,9	B6S	3510		
59673	5			-		0,9	XR5	3332	XR5IX	7355
59680	5			-		0,9	XR5	3332	XR5IX	7355
585411	5			-		0,9	XR5	3332	XR5IX	7355
585420	5			-		0,8	XR5	3332	XR5IX	7355
585430	5			-		0,8	XR5	3332	XR5IX	7355
585441	5			-		0,8	XR5	3332	XR5IX	7355
585460	5			-		0,8	XR5	3332	XR5IX	7355
585470	5			-		0,8	XR5	3332	XR5IX	7355
595410	5			-		0,9	XR5	3332	XR5IX	7355
595431	5			-		0,8	XR5	3332	XR5IX	7355
595440	5			-		0,8	XR5	3332	XR5IX	7355
59430	5,5			-		0,9	XR5	3332	XR5IX	7355
59431	5,5			-		0,9	XR5	3332	XR5IX	7355
59432	5,5			-		0,9	XR5	3332	XR5IX	7355
59433	5,5			-		0,9	XR5	3332	XR5IX	7355
59980	5,5			-		0,9	XR5	3332	XR5IX	7355
585710	5,5			-		0,9	XR5	3332	XR5IX	7355
6004	6			-		0,8	B-6L	3212		
6005	6			-		0,8	B-6L	3212		
60060	6			-		0,8	B-6L	3212		
58530	7			-		0,9	XR5	3332	XR5IX	7355
58531	7			-		0,9	XR5	3332	XR5IX	7355
58532	7			-		0,9	XR5	3332	XR5IX	7355
58830	7			-		0,9	XR5	3332	XR5IX	7355
59440	7			-		0,9	XR5	3332	XR5IX	7355
59840	7			-		0,9	XR5	3332	XR5IX	7355
59970	7			-		0,9	XR5	3332	XR5IX	7355
585860	7			-		0,8	XR5	3332	XR5IX	7355
585861	7			-		0,8	XR5	3332	XR5IX	7355
6008	7,5			-		0,8	B-6L	3212		
6010	7,5			-		0,8	B-6L	3212		
6012	7,5			-		0,8	B-6L	3212		
58809	7,5			-		0,9	XR5	3332	XR5IX	7355
58820	7,5			-		0,9	XR5	3332	XR5IX	7355
58821	7,5			-		0,9	XR5	3332	XR5IX	7355
58850	7,5			-		0,9	XR5	3332	XR5IX	7355
58880	7,5			-		0,9	XR5	3332	XR5IX	7355
58881	7,5			-		0,9	XR5	3332	XR5IX	7355
58882	7,5			-		0,9	XR5	3332	XR5IX	7355
58891	7,5			-		0,9	XR5	3332	XR5IX	7355
59450	7,5			-		0,9	XR5	3332	XR5IX	7355
59490	7,5			-		0,9	XR5	3332	XR5IX	7355
59491	7,5			-		0,9	XR5	3332	XR5IX	7355
60070	7,5			-		0,8	B-6L	3212		
60090	7,5			-		0,8	B-6L	3212		
60100	7,5			-		0,8	B-6L	3212		

	HP	c cm	C yl					Stock-Nº	TRUBIUM	Stock-NºX
585780	7,5			-		0,9	XR5	3332	XR5IX	7355
585810	7,5			-		0,8	XR5	3332	XR5IX	7355
585811	7,5			-		0,8	XR5	3332	XR5IX	7355
585821	7,5			-		0,9	XR5	3332	XR5IX	7355
585830	7,5			-		0,9	XR5	3332	XR5IX	7355
585840	7,5			-		0,8	XR5	3332	XR5IX	7355
585850	7,5			-		0,8	XR5	3332	XR5IX	7355
585880	7,5			-		0,9	XR5	3332	XR5IX	7355
585890	7,5			-		0,8	XR5	3332	XR5IX	7355
585910	7,5			-		0,9	XR5	3332	XR5IX	7355
585911	7,5			-		0,9	XR5	3332	XR5IX	7355
585920	7,5			-		0,8	XR5	3332	XR5IX	7355
585930	7,5			-		0,8	XR5	3332	XR5IX	7355
585931	7,5			-		0,9	XR5	3332	XR5IX	7355
586110	7,5			-		0,9	XR5	3332	XR5IX	7355
586111	7,5			-		0,9	XR5	3332	XR5IX	7355
586120	7,5			-		0,9	XR5	3332	XR5IX	7355
58710	9,9			-		0,8	XR5	3332	XR5IX	7355
58711	9,9			-		0,8	XR5	3332	XR5IX	7355
586210	9,9			-		0,8	XR5	3332	XR5IX	7355
586211	9,9			-		0,8	XR5	3332	XR5IX	7355
586220	9,9			-		0,8	XR5	3332	XR5IX	7355
586230	9,9			-		0,8	XR5	3332	XR5IX	7355
586231	9,9			-		0,8	XR5	3332	XR5IX	7355
586240	9,9			-		0,8	XR5	3332	XR5IX	7355
58720	10,5			-		0,8	XR5	3332	XR5IX	7355
58721	10,5			-		0,8	XR5	3332	XR5IX	7355
5927	12			-		0,8	B-6L	3212		
6013	14			-		0,8	B6S	3510		
6014	14			-		0,8	B6S	3510		
6015	14			-		0,8	B6S	3510		
58105	15			-		0,8	B7HS	5110	BR7HIX	7067
58760	15			-		0,8	XR5	3332	XR5IX	7355
58761	15			-		0,8	XR5	3332	XR5IX	7355
586310	15			-		0,8	XR5	3332	XR5IX	7355
586311	15			-		0,8	XR5	3332	XR5IX	7355
586320	15			-		0,8	XR5	3332	XR5IX	7355
586330	15			-		0,8	XR5	3332	XR5IX	7355
586331	15			-		0,8	XR5	3332	XR5IX	7355
586340	15			-		0,8	XR5	3332	XR5IX	7355
26033	27,7			-		0,8	B6S	3510		
26035	27,7			-		0,8	B6S	3510		
6037	28			-		0,8	B6S	3510		
6038	28			-		0,8	B6S	3510		
60340	28			-		0,8	B8S	3810		
60360	28			-		0,8	B8S	3810		
60370	28			-		0,8	B8S	3810		
60380	28			-		0,8	B8S	3810		
5941	35			-		0,8	B8S	3810		
6045	43,7			-		0,8	B6S	3510		
6050	43,7			-		0,8	B6S	3510		
60541	43,7			-		0,8	B6S	3510		
60644	43,7			-		0,8	B6S	3510		



HP

c
mC
y
l

Stock-Nº

FRIDUM

Stock-NºX

5056	45			-		0,8	B8S	3810		
5057	45			-		0,8	B8S	3810		
5058	45			-		0,8	B8S	3810		
60540	45			-		0,8	B8S	3810		
60550	45			-		0,8	B8S	3810		
6078	75			-		0,8	B8S	3810		
60740	75			-		0,8	B8S	3810		
60750	75			-		0,8	B8S	3810		
6070	75,2			-		0,8	B6S	3510		
6071	75,2			-		0,8	B6S	3510		
6076	75,2			-		0,8	B8S	3810		
6077	75,2			-		0,8	B8S	3810		

SELVA

S 110				-		0,5	BP6HS	4511	BPR6HIX	4085
S 120				-		0,5	BP6HS	4511	BPR6HIX	4085
S 125				-		0,5	BP6HS	4511	BPR6HIX	4085
S 95SC				-		0,5	BP6HS	4511	BPR6HIX	4085
S 115SC				-		0,5	BP6HS	4511	BPR6HIX	4085
S 135SC				-		0,5	BP6HS	4511	BPR6HIX	4085
S 130				-		0,5	BP6HS	4511	BPR6HIX	4085
S 170				-		0,5	BP6HS	4511	BPR6HIX	4085
S 155				-		0,5	BP6HS	4511	BPR6HIX	4085
S 250				-		0,5	BP6HS	4511	BPR6HIX	4085
S 350				-		0,5	BP6HS	4511	BPR6HIX	4085
S 400				-		0,5	BP7HS	5111	BPR7HIX	5944
S 490				-		0,5	BP7HS	5111	BPR7HIX	5944
S500				-		0,5	B6HS	4510	BR6HIX	3419
S850				-		0,5	B8HS	5510	BR8HIX	7001
S700				-		0,5	B8HS	5510	BR8HIX	7001
S750				-		0,5	B8HS	5510	BR8HIX	7001
S800				-		0,5	B8HS	5510	BR8HIX	7001
Elba	2,4	56		-		0,5	BPMR6A	6726		
S60 SI	2,5			-		0,5	BPM6A	7021		
S 85	4	85	1	-		0,5	BP6HS	4511	BPR6HIX	4085
S 95	5	123	1	-		0,5	BP6HS	4511	BPR6HIX	4085
S 115	5			-		0,5	BP6HS	4511	BPR6HIX	4085
Capri	5	125		-		0,8	BPR6HS	7022	BPR6HIX	4085
S115	5			-		0,5	BPR6HS	7022	BPR6HIX	4085
S115 SI	5			-		0,5	BPR6HS	7022	BPR6HIX	4085
S 135	6	123	1	-		0,5	BP6HS	4511	BPR6HIX	4085
Izmir	8	170		-		0,8	BPR6HS	7022	BPR6HIX	4085
S165	8			-		0,5	BPR6HS	7022	BPR6HIX	4085
S 165	8,11	170	2	-		0,5	BP6HS	4511	BPR6HIX	4085
S 175	9,98	259	2	-		0,5	BP6HS	4511	BPR6HIX	4085
S 260	15	259	2	-		0,5	BP6HS	4511	BPR6HIX	4085
S 495XS	20	489	2	-		0,5	BP6HS	4511	BPR6HIX	4085
S 405	20			-		0,5	BP7HS	5111	BPR7HIX	5944
Rhodes	20	398		-		0,8	BPR6HS	7022	BPR6HIX	4085
S405	20			-		0,5	BPR6HS	7022	BPR6HIX	4085
S 495	25	489	2	-		0,5	BP7HS	5111	BPR7HIX	5944
S600 Master	25			-		0,5	B8HS	5510	BR8HIX	7001

	HP	c m	C y l					Stock-Nº		FRIDIUM		Stock-NºX	
S800 Best	25			-				0,5	B8HS	5510	BR8HIX	7001	
Antibes	25	489		-				0,8	BPR6HS	7022	BPR6HIX	4085	
Majorca	25	489		-				0,8	BPR6HS	7022	BPR6HIX	4085	
Master	25			1989-				0,5	B8HS	5510	BR8HIX	7001	
S495	25			-				0,5	BPR6HS	7022	BPR6HIX	4085	
S500 Grand Prix	25			-				1,0	B7HS-10	2129			
S600 Master	25			-				1,0	B7HS-10	2129			
S800 Best	25			-				1,0	B7HS-10	2129			
S1050 Super Best	25			-				1,0	B7HS-10	2129			
XS	25	495		1988-	2 carb.			0,5	BP6HS	4511	BPR6HIX	4085	
S505 Antibes	30	489		-				1,0	B7HS-10	2129			
S 505	32	489	2	-				0,5	BP7HS	5111	BPR7HIX	5944	
S525 Majorca	35	489		-				1,0	B7HS-10	2129			
other models	35			-				0,5	B8HS	5510	BR8HIX	7001	
S 525	35,3	489	2	-				0,5	BP6HS	4511	BPR6HIX	4085	
S650	40			-				0,5	B8HS	5510	BR8HIX	7001	
S625 Madeira	40	684		-				1,0	B7HS-10	2129			
Saint Tropez	40	741		-				1,0	B7HS-10	2129			
S650	50			1989-				0,5	B8HS	5510	BR8HIX	7001	
S650	50			-				0,5	B8HS	5510	BR8HIX	7001	
S700 Madeira	50	684	2	-				1,0	B7HS-10	2129			
Other Models	50			-				0,5	B8HS	5510	BR8HIX	7001	
S750	55			-				1,0	B7HS-10	2129			
Saint Tropez	60	831	3	-				1,0	B7HS-10	2129			
S850	65			-				1,0	B7HS-10	2129			
Other Models	65			-				0,5	B8HS	5510	BR8HIX	7001	
Tenerifa	70	831		-				1,0	B7HS-10	2129			
7S1300 Endurance	74,5			-				1,0	B7HS-10	2129			
Montecarlo	75	1298		-				1,0	B7HS-10	2129			
S1000	80			-				0,5	B8HS	5510	BR8HIX	7001	
Other Models	80			-				0,5	B8HS	5510	BR8HIX	7001	
S1000 Potofino	80	1025	3	-				1,0	B7HS-10	2129			
S1350	90			-				0,5	B8HS	5510	BR8HIX	7001	
S1350 Montecarlo	90	1298		-				1,0	B7HS-10	2129			
S1400	100			-				0,5	B8HS	5510	BR8HIX	7001	
S1400 Montecarlo	100	1368		-				1,0	B7HS-10	2129			
SPRITE													
J5				-				0,8	BM4A	5628			
SUZUKI													
DT2	2			1977-1989				0,7	B-4H	4110			
DT2	2			1990-1997				0,7	BR5HS	3722			
DT2.2	2,2			1986-1992				0,7	B-4H	4110			
DT2.2	2,2		1	1993-1997				0,7	BR5HS	3722			
DF2.5	2,5		1	2006-				-	CR6HSA	2983	CR6HIX	7274	
DT3.5	3,5		1	1977-1984				0,7	BP6HS	4511	BPR6HIX	4085	
DF4	4		1	2003-2010				0,8	BPR6ES	7822	BPR6EIX	6637	
DF4	4		1	2011-				0,9	CPR6EA-9	6899	CPR6EAIX-9S	93921	
DF4A	4	138	1	2017-				0,8	CPR6EA-9	6899	CPR6EAIX-9S	93921	
DF4AL	4	138	1	2017-				0,8	CPR6EA-9	6899	CPR6EAIX-9S	93921	



HP







c
mC
y
l

Stock-No



Stock-NrX

DF4AS	4	138	1	2017-		0,8	CPR6EA-9	6899	CPR6EAIX-9S	93921
DF4L	4	138	1	-		0,8	CPR6EA-9	6899	CPR6EAIX-9S	93921
DF4S	4	138	1	-		0,8	CPR6EA-9	6899	CPR6EAIX-9S	93921
DT4	4		1	1985-1987		0,7	BP6HS	4511	BPR6HIX	4085
DT4	4		1	1988-1998		0,7	BPR5HS	6222		
DT4D	4		1	1977-1979		0,7	B6HS	4510	BR6HIX	3419
DT4.5	4,5		1	1977-1979		0,7	B6HS	4510	BR6HIX	3419
DF5	5		1	2002-2010		0,8	BPR6ES	7822	BPR6EIX	6637
DF5	5	138	1	2011-		0,8	CPR6EA-9	6899	CPR6EAIX-9S	93921
DF5A	5	138	1	2017-		0,8	CPR6EA-9	6899	CPR6EAIX-9S	93921
DF5AL	5	138	1	2017-		0,8	CPR6EA-9	6899	CPR6EAIX-9S	93921
DF5AS	5	138	1	2017-		0,8	CPR6EA-9	6899	CPR6EAIX-9S	93921
DF5L	5	138	1	2011-		0,8	CPR6EA-9	6899	CPR6EAIX-9S	93921
DF5S	5	138	1	2011-		0,8	CPR6EA-9	6899	CPR6EAIX-9S	93921
DT5	5			1999-2000		0,7	BPR5HS	6222		
DT5	5		2	1977-1983		0,6	BP6HS	4511	BPR6HIX	4085
DT5W	5			1986-1992		0,7	BR6HS	3922	BR6HIX	3419
DT5Y	5		1	1999-2002		1,0	BPR7HS-10	1092		
DF6	6		1	2003-2010		0,8	BPR6ES	7822	BPR6EIX	6637
DF6	6		1	2011-		0,9	CPR6EA-9	6899	CPR6EAIX-9S	93921
DF6A	6	138	1	2017-		0,8	CPR6EA-9	6899	CPR6EAIX-9S	93921
DF6AL	6	138	1	2017-		0,8	CPR6EA-9	6899	CPR6EAIX-9S	93921
DF6AS	6	138	1	2017-		0,8	CPR6EA-9	6899	CPR6EAIX-9S	93921
DF6L	6	138	1	2011-		0,8	CPR6EA-9	6899	CPR6EAIX-9S	93921
DF6S	6	138	1	2011-		0,8	CPR6EA-9	6899	CPR6EAIX-9S	93921
DT6	6		2	1984-1985		0,9	BP6HS	4511	BPR6HIX	4085
DT6	6		2	1986-1992		1,0	B6HS-10	1052		
DT6	6		2	1993-2002		1,0	BR6HS-10	1090		
DT7.5	7,5		2	1977-1979		0,7	B6HS	4510	BR6HIX	3419
DF8A	8		2	2010-		0,8	CR6E	6965		
DF8AR	8			2010-		0,8	CR6E	6965		
DT8	8		2	1977-1987		0,9	BP6HS	4511	BPR6HIX	4085
DT8C	8		2	1988-1992		1,0	B6HS-10	1052		
DT8C	8		2	1993-1997		1,0	BR6HS-10	1090		
DT9	9		2	1977-1979		0,7	B6HS	4510	BR6HIX	3419
DF9.9	9,9		2	1996-2004		0,9	DCPR6E	3481	DCPR6EIX	8196
DF9.9	9,9		2	2005-2010		0,8			BKR6EIX	6418
DF9.9	9,9		2	2011-		0,9	CPR6EA-9	6899	CPR6EAIX-9S	93921
DF9.9A	9,9		2	2010-2011		0,8	CR6E	6965		
DF9.9B	9,9	327	2	2013-		0,8	CPR6EA-9	6899	CPR6EAIX-9S	93921
DF9.9BL	9,9	327	2	2013-		0,8	CPR6EA-9	6899	CPR6EAIX-9S	93921
DF9.9BR	9,9	327	2	-		0,8	CPR6EA-9	6899	CPR6EAIX-9S	93921
DF9.9BRL	9,9	327	2	-		0,8	CPR6EA-9	6899	CPR6EAIX-9S	93921
DF9.9BRS	9,9	327	2	-		0,8	CPR6EA-9	6899	CPR6EAIX-9S	93921
DF9.9BS	9,9	327	2	2013-		0,8	CPR6EA-9	6899	CPR6EAIX-9S	93921
DT9.9	9,9		2	1977-1982		1,0	BR7HS-10	1098		
DT9.9	9,9		2	1983-1985		1,0	B7HS-10	2129		
DT9.9	9,9		2	1986-1988		1,0	B6HS-10	1052		
DT9.9C	9,9		2	1988-1991		0,7	B6HS	4510	BR6HIX	3419
DT9.9C	9,9		2	1992-		1,0	B6HS-10	1052		
DT9.9C	9,9		2	1993-1997		1,0	BR6HS-10	1090		
DT9.9E	9,9			1984-		0,7	B7HS	5110	BR7HIX	7067
DT9.9K	9,9			-		1,0	BR6HS-10	1090		

	HP	c c m	C y l					Stock-Nº		Stock-NºX		
DT9.9P	9,9			-1983				0,7	B6HS	4510	BR6HIX	3419
DF15	15		2	1996-2004				0,9	DCPR6E	3481	DCPR6EIX	8196
DF15	15		2	2005-2010				0,8			BKR6EIX	6418
DF15	15		2	2011-				0,9	CPR6EA-9	6899	CPR6EAIX-9S	93921
DF15A	15	327	2	2013-				0,8	CPR6EA-9	6899	CPR6EAIX-9S	93921
DF15AE	15	327	2	-				0,8	CPR6EA-9	6899	CPR6EAIX-9S	93921
DF15AEL	15	327	2	-				0,8	CPR6EA-9	6899	CPR6EAIX-9S	93921
DF15AES	15	327	2	-				0,8	CPR6EA-9	6899	CPR6EAIX-9S	93921
DF15AL	15	327	2	2013-				0,8	CPR6EA-9	6899	CPR6EAIX-9S	93921
DF15AR	15	327	2	-				0,8	CPR6EA-9	6899	CPR6EAIX-9S	93921
DF15ARL	15	327	2	-				0,8	CPR6EA-9	6899	CPR6EAIX-9S	93921
DF15ARS	15	327	2	-				0,8	CPR6EA-9	6899	CPR6EAIX-9S	93921
DF15AS	15	327	2	2013-				0,8	CPR6EA-9	6899	CPR6EAIX-9S	93921
DF15AT	15	327	2	-				0,8	CPR6EA-9	6899	CPR6EAIX-9S	93921
DF15ATL	15	327	2	-				0,8	CPR6EA-9	6899	CPR6EAIX-9S	93921
DT15	15		2	1983-1988				0,7	B7HS	5110	BR7HIX	7067
DT15C	15		2	1989-1991				1,0	B7HS-10	2129		
DT15C	15		2	1992-1997				1,0	BR7HS-10	1098		
DT15K	15			-1985				0,7	BR6HS	3922	BR6HIX	3419
DT15K	15			1986-				0,7	B6HS	4510	BR6HIX	3419
DT16	16		2	1977-1982				0,7	B7HS	5110	BR7HIX	7067
DT16P	16			-				0,7	B7HS	5110	BR7HIX	7067
DF20A	20	327	2	2013-				0,8	CPR6EA-9	6899	CPR6EAIX-9S	93921
DF20AE	20	327	2	-				0,8	CPR6EA-9	6899	CPR6EAIX-9S	93921
DF20AEL	20	327	2	-				0,8	CPR6EA-9	6899	CPR6EAIX-9S	93921
DF20AES	20	327	2	-				0,8	CPR6EA-9	6899	CPR6EAIX-9S	93921
DF20AL	20	327	2	2013-				0,8	CPR6EA-9	6899	CPR6EAIX-9S	93921
DF20AR	20	327	2	-				0,8	CPR6EA-9	6899	CPR6EAIX-9S	93921
DF20ARL	20	327	2	-				0,8	CPR6EA-9	6899	CPR6EAIX-9S	93921
DF20ARS	20	327	2	-				0,8	CPR6EA-9	6899	CPR6EAIX-9S	93921
DF20AS	20	327	2	2013-				0,8	CPR6EA-9	6899	CPR6EAIX-9S	93921
DF20AT	20	327	2	-				0,8	CPR6EA-9	6899	CPR6EAIX-9S	93921
DF20ATL	20	327	2	-				0,8	CPR6EA-9	6899	CPR6EAIX-9S	93921
DF20ATS	20	327	2	-				0,8	CPR6EA-9	6899	CPR6EAIX-9S	93921
DT20	20			1995-1996				1,0	BR7HS-10	1098		
DT20	20		2	1977-1988				0,7	B7HS	5110	BR7HIX	7067
DT20K	20			-1985				1,0	BR7HS-10	1098		
DT20K	20			1986-1987				1,0	B7HS-10	2129		
DT20P	20			-1985				0,7	B7HS	5110	BR7HIX	7067
DF25	25			2010-				-	CR6HSA	2983	CR6HIX	7274
DF25	25		3	2000-2006				0,9	DCPR6E	3481	DCPR6EIX	8196
DF25	25		2	2006-2011	V-Twin			0,8			BKR6EIX	6418
DF25A	25	490	3	2014-				0,8	CPR6EA-9	6899	CPR6EAIX-9S	93921
DF25AL	25	490	3	2014-				0,8	CPR6EA-9	6899	CPR6EAIX-9S	93921
DF25AR	25	490	3	-				0,8	CPR6EA-9	6899	CPR6EAIX-9S	93921
DF25ARL	25	490	3	-				0,8	CPR6EA-9	6899	CPR6EAIX-9S	93921
DF25ARS	25	490	3	-				0,8	CPR6EA-9	6899	CPR6EAIX-9S	93921
DF25AS	25	490	3	2014-				0,8	CPR6EA-9	6899	CPR6EAIX-9S	93921
DF25AT	25	490	3	-				0,8	CPR6EA-9	6899	CPR6EAIX-9S	93921
DF25ATL	25	490	3	-				0,8	CPR6EA-9	6899	CPR6EAIX-9S	93921
DT25	25		3	1977-1988				1,0	B7HS-10	2129		
DT25	25		3	1985-1988				1,0	B7HS-10	2129		
DT25	25		3	1998-				1,0	BR7HS-10	1098		



HP







c
mC
y
l

Stock-Nº

FRIDUM

Stock-NºX

DT25C	25		3	1989-1992		1,0	B7HS-10	2129		
DT25C	25		3	1993-1995		1,0	BR7HS-10	1098		
DT25C	25		3	1993-2000		1,0	BR7HS-10	1098		
DT25E	25			-1982		0,7	B7HS	5110	BR7HIX	7067
DT25E	25			1983-1985		1,0	BPR7HS-10	1092		
DT25E	25			1986-		1,0	BR7HS-10	1098		
DT25K	25			-1997		1,0	B7HS-10	2129		
DT25K	25			1998-		0,7	B7HS	5110	BR7HIX	7067
DT25P	25			-		0,7	B7HS	5110	BR7HIX	7067
DT28	28			-1983		0,7	B7HS	5110	BR7HIX	7067
DT28E	28			-1983		0,7	B7HS	5110	BR7HIX	7067
DT28P	28			-1983		0,7	B7HS	5110	BR7HIX	7067
DF30	30		3	2000-2007		0,9	DCPR6E	3481	DCPR6EIX	8196
DF30A	30	490	3	2014-		0,8	CPR6EA-9	6899	CPR6EAIX-9S	93921
DF30AT	30	490	3	-		0,8	CPR6EA-9	6899	CPR6EAIX-9S	93921
DF30ATH	30	490	3	-		0,8	CPR6EA-9	6899	CPR6EAIX-9S	93921
DF30ATHL	30	490	3	-		0,8	CPR6EA-9	6899	CPR6EAIX-9S	93921
DF30ATL	30	490	3	-		0,8	CPR6EA-9	6899	CPR6EAIX-9S	93921
DF30ATS	30	490	3	-		0,8	CPR6EA-9	6899	CPR6EAIX-9S	93921
DT30	30		1	1983-1985		1,0	B7HS-10	2129		
DT30	30		2	1986-1987		1,0	B7HS-10	2129		
DT30C	30		3	1988-1992		1,0	B7HS-10	2129		
DT30C	30		3	1993-1998		1,0	BR7HS-10	1098		
DT30C	30		3	1996-1998		1,0	BR7HS-10	1098		
DT30E	R 30			1983-		1,0	BR7HS-10	1098		
DT35	35		2	1980-1982		0,9	BR8HS	4322	BR8HIX	7001
DT35	35		2	1987-1989		1,0	B8HS-10	5126		
DF40	40		3	1999-2010		0,9	DCPR6E	3481	DCPR6EIX	8196
DF40A	40		3	2011-		0,9	DCPR6E	3481	DCPR6EIX	8196
DT40	40		2	1980-1982		0,9	BR8HS	4322	BR8HIX	7001
DT40	40		2	1983-1985		0,9	B8HS	5510	BR8HIX	7001
DT40C	40		2	1984-1992		0,9	B8HS	5510	BR8HIX	7001
DT40C	40		2	1993-		0,9	BR8HS	4322	BR8HIX	7001
DT40C	40		2	1994-1998		1,0	BR8HS-10	1134		
DT40CR	40			1994-1998		1,0	BR8HS-10	1134		
DT40K	40			-		1,0	B7HS-10	2129		
DT40KR	40			-		1,0	B7HS-10	2129		
DT40TC	40			1994-1998		1,0	BR8HS-10	1134		
DT40W	40			-1997		0,9	B8HS	5510	BR8HIX	7001
DT40W	40			1998-		1,0	B8HS-10	5126		
DT40WK	40			-1997		0,9	B8HS	5510	BR8HIX	7001
DT40WK	40			1998-		1,0	B8HS-10	5126		
PU40	40		2	1989-1992		0,9	B8HS	5510	BR8HIX	7001
PU40	40		2	1993-		0,9	BR8HS	4322	BR8HIX	7001
PU40	40		2	1994-1995		1,0	BR8HS-10	1134		
DF46	46		3	2005-2008		0,8	BPR6ES	7822	BPR6EIX	6637
DT48M	48			-2000		0,9	B8HS	5510	BR8HIX	7001
DT48M	48			2001-		1,0	B8HS-10	5126		
DF50	50		3	1999-2010		0,9	DCPR6E	3481	DCPR6EIX	8196
DF50A	50		3	2011-		0,9	DCPR6E	3481	DCPR6EIX	8196
DT50	50		2	1977-1990		1,0	B8HS-10	5126		
DT50ACR	50			1994-1996		1,0	BR8HS-10	1134		
DT50C	50			1984-2000		1,0	B8HS-10	5126		

	HP	c c m	C y l					Stock-Nº		Stock-NºX			
DT50C	50			2001-				1,0	BR8HS-10	1134			
DT50K	50			-				0,9	B7HS	5110	BR7HIX	7067	
DT50M	50			-1985				0,9	B8HS	5510	BR8HIX	7001	
DT50M	50			1986-1989				0,9	B8HS-10	5126			
DT50M	50			2001-				1,0	BR8HS-10	1134			
DT50T	50			-1985				0,9	B8HS	5510	BR8HIX	7001	
DT50W	50			-1985				0,9	B8HS	5510	BR8HIX	7001	
DT50W	50			1986-1989				0,9	B8HS-10	5126			
DT50W	50			2001-				1,0	BR8HS-10	1134			
DT55	55		3	1985-1992				0,9	B8HS	5510	BR8HIX	7001	
DT55	55		3	1993-1995				0,8	BR8HS	4322	BR8HIX	7001	
DT55	55		3	1996-1997				1,0	BR8HS-10	1134			
DT55C	55			-				1,0	BR8HS-10	1134			
DT55CRQ	55			-				1,0	BR8HS-10	1134			
DT55M	55			-				1,0	BR8HS-10	1134			
DT55TC	55			-				1,0	BR8HS-10	1134			
PU55	55		3	1989-1993				0,9	B8HS	5510	BR8HIX	7001	
PU55	55		3	1994-1995				1,0	BR8HS-10	1134			
DF60	60		3	1998-2009				0,8	BPR6ES	7822	BPR6EIX	6637	
DF60A	60		3	2010-				0,9	DCPR6E	3481	DCPR6EIX	8196	
DT60	60		3	1983-1984				0,9	B8HS	5510	BR8HIX	7001	
DT60C	60			1986-1987				1,0	B8HS-10	5126			
DT60C	60			2001-				1,0	BR8HS-10	1134			
DT60W	60			-1997				0,9	B8HS	5510	BR8HIX	7001	
DT60W	60			1998-				1,0	B8HS-10	5126			
DT65	65		3	1978-1983				0,9	B8HS	5510	BR8HIX	7001	
DT65	65		3	1985-1992				0,9	B8HS	5510	BR8HIX	7001	
DT65	65		3	1993-1995				0,8	BR8HS	4322	BR8HIX	7001	
DT65	65		3	1996-1997				1,0	BR8HS-10	1134			
DT65C	65			-1992				0,9	B8HS	5510	BR8HIX	7001	
DT65C	65			1993-				0,9	BR8HS	4322	BR8HIX	7001	
DT65T	65			-1983				0,9	B8HS	5510	BR8HIX	7001	
DT65TC	65			1993-1998				0,8	BR8HS	4322	BR8HIX	7001	
DT65TC	65			1998-				1,0	BR8HS-10	1134			
DF70	70		4	1998-2009				0,8	BPR6ES	7822	BPR6EIX	6637	
DF70A	70		4	2009-				0,9	DCPR6E	3481	DCPR6EIX	8196	
DF70THL	70		3	2005-2007				0,8	BPR6ES	7822	BPR6EIX	6637	
DF70TL	70		3	2005-2007				0,8	BPR6ES	7822	BPR6EIX	6637	
DT75	75		3	1983-1992				0,8	B8HS	5510	BR8HIX	7001	
DT75	75		3	1993-1996				0,8	BR8HS	4322	BR8HIX	7001	
DT75	75		3	1996-1997				1,0	BR8HS-10	1134			
DT75C	75			-2000				0,9	BR8HS	4322	BR8HIX	7001	
DT75C	75			2001-				1,0	BR8HS-10	1134			
DT75M	75			-2000				0,9	BR8HS	4322	BR8HIX	7001	
DT75M	75			2001-				1,0	BR8HS-10	1134			
DT75TC	75			-2000				0,8	B8HS	5510	BR8HIX	7001	
DT75TC	75			2001-				1,0	BR8HS-10	1134			
DF80A	80		4	2009-				0,9	DCPR6E	3481	DCPR6EIX	8196	
DT85	85		3	1979-1992				0,9	B8HS	5510	BR8HIX	7001	
DT85	85		3	1993-				0,9	BR8HS	4322	BR8HIX	7001	
DT85	85		3	1994-2000				1,0	BR8HS-10	1134			
DT85C	85			-1992				0,9	B8HS	5510	BR8HIX	7001	
DT85C	85			1993-2000				0,9	BR8HS	4322	BR8HIX	7001	



HP





c
c
mC
y
l

Stock-Nr

FRIDUM

Stock-NrX

DT85C	85		2001-		1,0	BR8HS-10	1134		
DT85M	85		-2000		0,9	BR8HS	4322	BR8HIX	7001
DT85M	85		2001-		1,0	BR8HS-10	1134		
DT85MQ	85		1995-1996		1,0	B8HS-10	5126		
DT85Q	85		-2000		0,9	BR8HS	4322	BR8HIX	7001
DT85Q	85		2001-		1,0	BR8HS-10	1134		
DT85TC	85		-2000		0,9	BR8HS	4322	BR8HIX	7001
DT85TC	85		2001-		1,0	BR8HS-10	1134		
DT85W	85		-2000		0,9	BR8HS	4322	BR8HIX	7001
DT85W	85		2001-		1,0	BR8HS-10	1134		
DT85WT	85		-		1,0	B8HS-10	5126		
PU85	85	3	1989-1993		0,9	B8HS	5510	BR8HIX	7001
PU85	85	3	1994-1997		1,0	BR8HS-10	1134		
DT86	86		-2000		0,9	B8HS	5510	BR8HIX	7001
DT86	86		2001-		1,0	BR8HS-10	1134		
DF90	90	4	2001-2008		0,8			BKR6EIX	6418
DF90A	90	4	2009-		0,9	DCPR6E	3481	DCPR6EIX	8196
DT90	90	4	1989-1990		1,0	BR8HS-10	1134		
DT90	90	4	1991-1995		1,0	BR8HCS-10	1157		
DT90	90	4	1996-1997		1,0	BR8HS-10	1134		
DT90TC	90		-1995		1,0	BR8HCS-10	1157		
DT90TC	90		1996-1997		0,9	BR8HS	4322	BR8HIX	7001
DT90TC	90		1998-		1,0	BR8HS-10	1134		
DF99AR	99	4	2010-		0,8	CR6E	6965		
DF99TH	99	4	2010-		0,9	DCPR6E	3481	DCPR6EIX	8196
DF100	100	4	2009-2010		0,8			BKR6EIX	6418
DF100A	100	4	2009-2010		0,8			BKR6EIX	6418
DT100	100	4	1989-1990		1,0	BR8HS-10	1134		
DT100	100	4	1991-1995		1,0	BR8HCS-10	1157		
DT100	100	4	1996-2000		1,0	BR8HS-10	1134		
DT100TC	100		-1995		1,0	BR8HCS-10	1157		
DT100TC	100		1996-1997		0,9	BR8HS	4322	BR8HIX	7001
DT100TC	100		1998-		1,0	BR8HS-10	1134		
DF115	115	4	2001-2011		0,8			BKR6EIX	6418
DT115	115	4	1981-1990		0,9	B8HS	5510	BR8HIX	7001
DT115	115	4	1991-1997		1,0	BR8HCS10	1157		
DT115	115	4	1998-2000		0,9	BR8HS	4322	BR8HIX	7001
DT115S	115	4	1996-2001	EFI	1,0	BR8HS10	1134		
1DT115STC	115		1996-2001	EFI	1,0	BR8HS-10	1134		
DF140	140	4	2002-2011		0,8			BKR6EIX	6418
DT140	140	4	1981-1995		1,0	B8HS10	5126		
DT140	140	4	1986-1995		1,0	B8HS10	5126		
DT140	140	4	1996-		1,0	BR8HCS10	1157		
DT140	140	4	1997-2000		0,9	BR8HS	4322	BR8HIX	7001
DT140	140	4	1997-2001	EFI	1,0	BR8HS10	1134		
1DT140T	140		-2000		1,0	BR8HCS-10	1157		
1DT140T	140		2001-		1,0	BR8HS-10	1134		
1DT140TC	140		1991-1996		1,0	BR8HCS-10	1157		
1DT140TC	140		1997-		1,0	BR8HS-10	1134		
PU140	140	4	1989-1995		1,0	BR8HCS10	1157		
PU140	140	4	1996-1997		1,0	BR8HS10	1134		
DF 150 AP	150	4	2017-		0,9	LKR6E	92650		
DT150	150	6	1986-1997		1,0	BR8HS-10	1134		

	HP	c m	C y l					Stock-Nº		Stock-NºX
DT150	150		6	1987-2003	EFI	1,0	BR8HS-10	1134		
DT150G	150			-		1,0	BR8HS-10	1134		
DT150S	150		6	1987-2003	EFI	1,0	BR8HS-10	1134		
DT150SS	150		6	1986-1988		1,0	B8HS-10	5126		
DT150SS	150		6	1989-1992		1,0	BR8HS-10	1134		
DT150STC	150			-		1,0	BR8HS-10	1134		
DF175	175		4	2006-2011		1,0			BKR6EIX	6418
DF175 AP	175		4	2017-		0,9	LKR6E	92650		
DT175	175		6	1987-1992		1,0	BR8HS-10	1134		
DF200	200		6	2004-		1,0			BKR6EIX	6418
DF200 A	200		4	2014-		0,9	LKR6E	92650		
DF200 AP	200		4	2015-		0,9	LKR6E	92650		
DT200 Carb.	200		6	1986-		1,0	B8HS-10	5126		
DT200 Carb.	200		6	1987-1997		1,0	BR8HS-10	1134		
DT200	200		6	1987-2000	EFI	1,0	BR8HS-10	1134		
DT200V Carb.	200		6	1987-1988		1,0	B8HS-10	5126		
DT200V Carb.	200		6	1989-1991		1,0	BR8HS-10	1134		
DT225	225		6	1987-2003		1,0	BR8HS-10	1134		
DF225	225		6	2004-2011		0,9			BKR6EIX	6418
DF250	250		6	2004-2011		1,0			BKR6EIX	6418
DF300	300		6	2007-2011		0,9			BKR6EIX	6418
TANAKA										
Aqua Bug				-		0,6	BM6A	5921		
Bumble Bee				1992-		0,6	BM6F	6221		
Super Bug				-		0,6	BM6A	5921		
TOB12	1,2			1972-1989		0,6	BMR6A	7421		
TOB12	1,2			-		0,6	BM6A	2680		
TOB120	1,2			1981-1998		0,6	BMR6A	7421		
TOB 175	1,75			1981-1990		0,6	BMR6A	7421		
TOB 25	2,5			-1985		0,6	BM6A	2680		
TOB 25	2,5			1986-		0,6	BMR6A	3850		
TOB 300	3			1981-1999		0,6	BMR6A	7421		
TOB 550	5,5			1984-1988		0,6	BPR7HS	6422	BPR7HIX	5944
TOB 550L	5,5			1984-1988		0,6	BPR7HS	6422	BPR7HIX	5944
TERRY TROLLER										
T4T				-		0,6	BR6S	3522		
TOHATSU										
MFS2A	2	85,5	1	2007-2008		0,6	DCPR6E	3481	DCPR6EIX	8196
M2.5A	2,5		1	1980-1996		1,0	BP6HS-10	6326		
M2.5A	2,5		1	1997-2007		1,0	BPR6HS-10	2633		
M2.5A2	2,5		1	-		1,0	BP6HS-10	6326		
M2.5B	2,5	85,5	1	-		0,6	DCPR6E	3481	DCPR6EIX	8196
M3.5A	3,5	85,5	1	1986-1990		1,0	BP6HS-10	6326		
M3.5A	3,5	85,5	1	1997-2007		1,0	BPR6HS-10	2633		
M3.5A2	3,5		1	-		1,0	BPR6HS-10	2633		
M3.5B	3,5	85,5	1	1991-1996		1,0	BP6HS-10	6326		
M3.5B	3,5	85,5	1	1997-2007		1,0	BPR6HS-10	2633		



HP







c
mC
y
l

Stock-Nr

FRIBUM

Stock-NrX

M3.5B2	3,5		1	-		1,0	BPR6HS-10	2633		
MFS3.5A	3,5		1	2007-2008		0,6	DCPR6E	3481	DCPR6EIX	8196
MFS3.5A2	3,5		1	-		1,0	BP6HS-10	6326		
MFS3.5B2	3,5		1	-		1,0	BP6HS-10	6326		
M4C	4		1	1997-		1,0	BPR7HS-10	1092		
MFS4A	4		1	2000-2008		0,6	DCPR6E	3481	DCPR6EIX	8196
MFS4A2	4		1	2004-2008		0,6	DCPR6E	3481	DCPR6EIX	8196
MFS4B	4		1	-		0,6	DCPR6E	3481	DCPR6EIX	8196
MFS4C	4		1	-		0,6	DCPR6E	3481	DCPR6EIX	8196
M5A2	5		1	1978-1983		0,6	B7HS	5110	BR7HIX	7067
M5B	5		1	1983-1996		1,0	BP7HS-10	7829		
M5B	5		1	1997-2007		1,0	BPR7HS-10	1092		
M5BS	5		1	2007-		1,0	BPR7HS-10	1092		
MFS5	5		1	-		0,6	DCPR6E	3481	DCPR6EIX	8196
MFS5A	5		1	1999-2007		0,6	DCPR6E	3481	DCPR6EIX	8196
MFS5A2	5		1	2004-2007		0,6	DCPR6E	3481	DCPR6EIX	8196
MFS5B	5		1	-		0,6	DCPR6E	3481	DCPR6EIX	8196
MFS5C	5		1	-		0,6	DCPR6E	3481	DCPR6EIX	8196
M6B	6		2	1997-		1,0	BPR7HS-10	1092		
MFS6A	6		1	2004-2008		0,6	DCPR6E	3481	DCPR6EIX	8196
MFS6A2	6		1	2004-2008		0,6	DCPR6E	3481	DCPR6EIX	8196
MFS6B	6		1	-		0,6	DCPR6E	3481	DCPR6EIX	8196
MFS6C	6		1	-		0,6	DCPR6E	3481	DCPR6EIX	8196
B13B	8	137	1	1974-1976		0,6	B7HS	5110	BR7HIX	7067
M8A	8		2	1976-1986		0,6	B7HS	5110	BR7HIX	7067
M8B	8		2	1986-1996		1,0	BP7HS-10	7829		
M8B	8		2	1997-2007		1,0	BPR7HS-10	1092		
MFS8A	8		2	2004-2008		0,6	DCPR6E	3481	DCPR6EIX	8196
MFS8A3	8		2	2004-2008		0,6	DCPR6E	3481	DCPR6EIX	8196
B18D	9,8	183		1974-1976		0,6	B7HS	5110	BR7HIX	7067
M9.8A	9,8		2	1976-1985		0,6	B7HS	5110	BR7HIX	7067
M9.8B	9,8		2	2000-2007		1,0	BPR7HS-10	1092		
MFS9.8A	9,8		2	2004-2008		0,6	DCPR6E	3481	DCPR6EIX	8196
M9.9B	9,9		2	1982-1986		0,8	B7HS-10	2129		
M9.9B2	9,9		2	1986-1994		0,8	B7HS-10	2129		
M9.9C	9,9		2	1994-2007		0,8	B7HS-10	2129		
M9.9D	9,9		2	1996-2007		0,8	B7HS-10	2129		
M9.9D2	9,9		2	-		0,8	BR7HS-10	1098		
MFS9.9A	9,9		2	2000-2008		0,6	DCPR6E	3481	DCPR6EIX	8196
MFS9.9B	9,9		2	2004-2008		0,6	DCPR6E	3481	DCPR6EIX	8196
MFS9.9B2	9,9		2	2004-2008		0,6	DCPR6E	3481	DCPR6EIX	8196
B18C	12	183	2	1974-1976		0,6	B7HS	5110	BR7HIX	7067
M12A	12		2	1976-1980		0,6	B7HS	5110	BR7HIX	7067
M12B	12		2	1980-1982		0,6	B7HS	5110	BR7HIX	7067
M12C	12		2	1982-1986		0,8	B7HS-10	2129		
M12C	12		2	2007-		0,8	B7HS-10	2129		
M15A	15		2	1980-1982		0,6	B7HS	5110	BR7HIX	7067
M15B	15		2	1982-1986		0,8	B7HS-10	2129		
M15B	15		2	2007-		0,8	BR7HS-10	1098		
M15B2	15		2	1986-1994		0,8	B7HS-10	2129		
M15C	15		2	1994-1996		0,8	BP7HS-10	7829		
M15C	15		2	2004-2007		0,8	B7HS-10	2129		
M15D	15		2	1997-2001		0,8	BPR7HS-10	1092		

	HP	c m	C y l					Stock-Nº		Stock-NºX
M15D	15		2	2000-2001		0,8	BPR7HS-10	1092		
M15D	15		2	2004-2007		0,8	B7HS-10	2129		
M15D2	15		2	-		0,8	B7HS-10	2129		
MFS15A	15		2	2000-2007		0,6	DCPR6E	3481	DCPR6EIX	8196
MFS15B	15		2	2004-2007		0,6	DCPR6E	3481	DCPR6EIX	8196
MFS15B2	15		2	2004-2007		0,6	DCPR6E	3481	DCPR6EIX	8196
MFS15C	15		2	-		0,8	B7HS-10	2129		
MFS15C	15		2	-		0,6	DCPR6E	3481	DCPR6EIX	8196
MFS15D	15		2	-		0,8	B7HS-10	2129		
MFS15D2	15		2	-		0,8	BR7HS-10	1098		
M18A	18		2	1980-1983		0,6	B7HS	5110	BR7HIX	7067
M18C	18		2	1982-1986		0,8	B7HS-10	2129		
M18C	18		2	2007-		0,8	BR7HS-10	1098		
M18C2	18		2	1986-1994		0,8	B7HS-10	2129		
M18D	18		2	1994-2007		0,8	B7HS-10	2129		
M18E	18		2	1996-		0,8	B7HS-10	2129		
M18E	18		2	1996-1999		0,8	BR7HS-10	1098		
M18E	18		2	2000-2001		0,8	BPR7HS-10	1092		
M18E	18		2	2004-2007		0,8	B7HS-10	2129		
M18E2	18		2	-		0,8	B7HS-10	2129		
MFS18B	18		2	2004-2008		0,6	DCPR6E	3481	DCPR6EIX	8196
MFS18B2	18		2	2004-2008		0,6	DCPR6E	3481	DCPR6EIX	8196
B30C	20	306		1974-1976		0,6	B7HS	5110	BR7HIX	7067
M20A2	20		2	1976-1980		0,6	B7HS	5110	BR7HIX	7067
MFS20C	20		2	-		0,6	DCPR6E	3481	DCPR6EIX	8196
B40A	25	397		1973-1976		0,6	B7HS	5110	BR7HIX	7067
M25A2	25		2	1976-1983		0,6	B7HS	5110	BR7HIX	7067
M25B	25		2	1979-1985		0,6	B7HS	5110	BR7HIX	7067
M25C	25		2	1984-1986		0,6	B7HS	5110	BR7HIX	7067
M25C2	25		2	1986-2007		0,8	B7HS-10	2129		
M25C2	25		2	-		1,0	BPR7HS-10	1092		
M25C3	25		2	1997-2007		0,8	BR7HS-10	1098		
M25C4	25		2	2000-2001		0,8	BR7HS-10	1098		
M25D	25		2	-		0,8	B7HS-10	2129		
MFS25A	25		3	2004-2008		0,6	DCPR6E	3481	DCPR6EIX	8196
MFS25B	25		3	2004-2008		0,6	DCPR6E	3481	DCPR6EIX	8196
M30A	30		2	1979-1981		0,8	B7HS-10	2129		
M30A2	30		2	1981-1986		0,8	B7HS-10	2129		
M30A3	30		2	1986-1996		0,8	B7HS-10	2129		
M30A3	30		2	1997-1999		0,8	BR7HS-10	1098		
M30A3	30		2	2004-2007		0,8	B7HS-10	2129		
M30A4	30		2	2000-2007		0,8	BR7HS-10	1098		
M30AK	30		2	-		0,8	B7HS	5110	BR7HIX	7067
MFS 30A	30		3	2004-2007		0,6	DCPR6E	3481	DCPR6EIX	8196
MFS 30B	30		3	2004-2007		0,6	DCPR6E	3481	DCPR6EIX	8196
M35A	35		2	1976-1980		0,6	B7HS	5110	BR7HIX	7067
M35B	35		2	1979-1982		0,6	B7HS	5110	BR7HIX	7067
M35C	35		2	1984-1990		0,6	B7HS	5110	BR7HIX	7067
M3D35B2	35		2	-	TLDI Jet Drive	0,8	IZFR6Q	91234		
M40A	40		3	1973-1976		0,6	B7HS	5110	BR7HIX	7067
M40C	40		2	1983-2006		0,8	B7HS-10	2129		
M40C	40		2	2007-		0,8	BR7HS-10	1098		
M40D	40		3	1989-1996		0,8	B7HS-10	2129		



HP





c
c
mC
y
l

Stock-Nr

FRIDUM

Stock-NrX

M40D	40		3	1997-2006		0,8	BR7HS-10	1098		
M40D	40		3	2007-		0,8	B7HS-10	2129		
M40D2	40		3	2004-2007		0,8	BR7HS-10	1098		
MD40A	40		3	2004-2007	TLDI	1,1	ZFR6F-11	4291	ZFR6FIX-11	6441
MD40B	40		3	2004-2008	TLDI	0,8	PZFR6H	7696		
MD40B2	40		3	-	TLDI	0,8	IZFR6Q	91234		
MFS4A2	42		3	-		0,6	DCPR6E	3481	DCPR6EIX	8196
M45A	45		3	-		1,0	BR8HS-10	1134		
M45A2	45		3	-		1,0	BR8HS-10	1134		
M50C	50		3	1986-1991		1,0	B8HS-10	5126		
M50C	50		3	2004-2006		1,0	B8HS-10	5126		
M50C	50		3	-		1,0	BR8HS-10	1134		
M50D	50		3	1990-1996		1,0	B8HS-10	5126		
M50D	50		3	1997-2006		1,0	BR8HS-10	1134		
M50D	50		3	2007-		1,0	B8HS-10	5126		
M50D2	50		3	2004-2007		1,0	BR8HS-10	1134		
MD50A	50		3	2004-2007	TLDI	1,1	ZFR6F-11	4291	ZFR6FIX-11	6441
MD50B	50		3	2004-2008	TLDI	0,8	PZFR6H	7696		
MD50B2	50		3	-	TLDI	0,8	IZFR6Q	91234		
W50	50			2004-2008	TLDI	0,8	PZFR6H	7696		
MFS5A2S	52		3	-		0,6	DCPR6E	3481	DCPR6EIX	8196
M55A	55		3	1980-1983		1,0	B8HS-10	5126		
M55B	55		3	1980-1986		1,0	B8HS-10	5126		
M55B	55		3	2004-2006		1,0	B8HS-10	5126		
BFT60	60		3	-			LMAR6C-9	1679		
M60A	60		3	1986-1991		1,0	B8HS-10	5126		
M60A	60		3	2004-2006		1,0	B8HS-10	5126		
M60A	60		2	-		1,0	BR8HS-10	1134		
M60B	60		3	1992-2007		1,0	B8HS-10	5126		
M60C	60		3	2004-2006		1,0	B8HS-10	5126		
M60C	60		3	2007-		1,0	BR8HS-10	1134		
MFS6A2S	62		3	-		0,6	DCPR6E	3481	DCPR6EIX	8196
M70A	70		2	1982-1986		1,0	B8HS-10	5126		
M70A	70		3	2004-2006		1,0	B8HS-10	5126		
M70A2	70		3	1986-1992		1,0	B8HS-10	5126		
M70A2	70		2	2004-2006		1,0	B8HS-10	5126		
M70B	70		3	1992-1996		1,0	B8HS-10	5126		
M70B	70		3	1997-2006		1,0	BR8HS-10	1134		
M70B	70		3	2007-		1,0	B8HS-10	5126		
M70C	70		3	2000-2007		1,0	BR8HS-10	1134		
MD70A2	70		3	2004-2008	TLDI	1,1	PZFR6H	7696		
MD70B	70		3	2004-2008	TLDI	0,8	PZFR6H	7696		
MD75C2	75		3	-		0,8	IZFR6Q	91234		
MFS8A3	83		3	-		0,6	DCPR6E	3481	DCPR6EIX	8196
M90A	90		3	1987-1996		1,0	B8HS-10	5126		
M90A	90		3	1997-2007		1,0	BR8HS-10	1134		
MD90A	90		3	2004-2008	TLDI	1,1	PZFR6H	7696		
MD90A2	90		3	2004-2008	TLDI	1,1	PZFR6H	7696		
MD90B	90		3	2004-2008	TLDI	0,8	PZFR6H	7696		
MD90C2	90		3	-	TLDI	0,8	IZFR6Q	91234		
M115A	115		4	1993-1995		1,0	B8HS-10	5126		
M115A	115		4	2004-2006		1,0	B8HS-10	5126		
M115A	115		4	-	TLDI	0,8	IZFR5J	5899		

	HP	c m	C y l					Stock-Nº	FRIDIUM	Stock-NºX		
M115A2	115		4	1995-1996				1,0	B8HS-10	5126		
M115A2	115		4	1997-2001				1,0	BR8HS-10	1134		
M115A2	115		4	2004-2006				1,0	BR8HS-10	1134		
MD115A2	115		4	-				0,8	IZFR5J	5899		
M120A	120		4	1990-1995				1,0	B8HS-10	5126		
M120A	120		4	2004-2006				1,0	B8HS-10	5126		
M120A	120		4	-				1,0	BR8HS-10	1134		
M120A2	120		4	1995-1996				1,0	B8HS-10	5126		
M120A2	120		4	1997-1999				1,0	BR8HS-10	1134		
M120A2	120		4	2007-				1,0	BR8HS-10	1134		
M140A	140		4	1989-1995				1,0	B8HS-10	5126		
M140A2	140		4	1995-1996				1,0	B8HS-10	5126		
M140A2	140		4	1997-2006				1,0	BR8HS-10	1134		

TOMOS

18				-				1,0	BPR7HS-10	1092		
18E				-				1,0	BPR7HS-10	1092		
T10				-				0,6	BR7HS	4122	BR7HIX	7067
T18				-				0,6	BR7HS	4122	BR7HIX	7067
T4RN				-				0,6	B6HS	4510	BR6HIX	3419
Electronic	4,4			-				0,6	B6HS	4510	BR6HIX	3419
Electronic 10	4,4			-				0,6	B6HS	4510	BR6HIX	3419
Electronic 10E	4,4			-				0,6	B6HS	4510	BR6HIX	3419
5	5			-				0,6	BR7HS	4122	BR7HIX	7067
TS4	5			-				0,6	BR7HS	4122	BR7HIX	7067
Lamo 06N	5			-				0,6	BR7HS	4122	BR7HIX	7067

VALMET

Terhi 3	3			-				0,7	BP5S	3011		
Terhi 3.5	3,5			-				0,5	B6S	3510		
Terhi 4.5	4,5			-				0,5	B6HS	4510	BR6HIX	3419
Terhi 5	5			-				0,5	B6HS	4510	BR6HIX	3419
Tern 6	6			-				0,5	B6HS	4510	BR6HIX	3419
Vire 7	7			-				0,5	B-4H	4110		
Terhi 9.9	9,9			-				0,5	B6HS	4510	BR6HIX	3419
Terhi 15	15			-				0,5	B6HS	4510	BR6HIX	3419
Tern 17	17			-				0,5	B6HS	4510	BR6HIX	3419
Terhi 20	20			-				0,5	B6HS	4510	BR6HIX	3419
Terhi 23	23			-				0,5	B6HS	4510	BR6HIX	3419
Tern 25	25			-				0,5	B6HS	4510	BR6HIX	3419
Terhi 40	40			-				0,5	B6HS	4510	BR6HIX	3419
Terhi 50	50			-				0,5	BP5HS	4111		

VOLVO PENTA

35				-1974				0,5	B6HS	4510	BR6HIX	3419
40				-1974				0,5	B6HS	4510	BR6HIX	3419
50				-1974				0,5	B6HS	4510	BR6HIX	3419
50A				-1974				0,5	B6HS	4510	BR6HIX	3419
60			2	1978-1979				0,5	B6HS	4510	BR6HIX	3419
80				1971-1974				0,5	B5HS	4210		



HP

c
mC
y
l

Stock-Nº

FRIBUM

Stock-NºX







80				1978-1979		0,5	B5HS	4210		
90		140	2	1975-1979		0,5	B6HS	4510	BR6HIX	3419
120				-		0,5	B5HS	4210		
140		200	2	1975-1979		0,5	B6HS	4510	BR6HIX	3419
200		333	2	1975-1979		-	BUHX	2522		
252				1973-1974		0,5	BP7HS	5111	BPR7HIX	5944
360				1971-1974		0,5	B6HS	4510	BR6HIX	3419
450				1975-1976		-	BUHX	2522		
550X				-1974		0,5	B8HS	5510	BR8HIX	7001
U22				-1974		0,5	B5HS	4210		
39	4		1	1973-1979		0,5	B6HS	4510	BR6HIX	3419
51	5,5		1	1975-1978		0,5	B6HS	4510	BR6HIX	3419
90	10		2	1971-1974		0,5	B5HS	4210		
140	14		2	1972-1974		0,5	B5HS	4210		
250	25		2	1975-1975		-	BUHX	2522		
350	40		3	1975-1976		0,5	B8HS	5510	BR8HIX	7001
450	50		3	1971-1974		0,5	B8HS	5510	BR8HIX	7001
600	60		3	1973-1976		-	BUHX	2522		
700	75		3	1973-1977		-	BUHX	2522		
140		200	2	1972-1979		0,5	B5HS	4210		
U22				-1974		0,5	B6HS	2417		
90	10		2	1971-1979		0,5	B5HS	4210		

VOYAGER

V4GS				-		0,8	AB-6	2910		
V2L	3,5		1	-		0,8	AB-6	2910		
V2LL	3,5		1	-		0,8	AB-6	2910		
1VA	4,2		1	-		0,8	AB-6	2910		
2VA	4,2		1	-		0,8	AB-6	2910		
1VB	4,2		1	-		0,8	AB-6	2910		
V2N	4,2		1	-		0,8	AB-6	2910		
V3LGS	5,5		2	-		0,8	BR6S	3522		
V3LLGS	5,5		2	-		0,8	BR6S	3522		
V3LGS	5,5		2	-		0,8	B6S	2319		
V3LLGS	5,5		2	-		0,8	B6S	2319		
V3NGS	6		2	-		0,8	BR6S	3522		
V3NGS	6		2	-		0,8	B6S	2319		
V4LLGS	7,5		2	-		0,8	BR6S	3522		
V4LLGS	7,5		2	-		0,8	B6S	2319		
V4NGS	7,8		2	-		0,8	BR6S	3522		
V4NGS	7,8		2	-		0,8	B6S	2319		
V6LLGS	15		2	-		0,8	BR6S	3522		
V6NGS	15		2	-		0,8	BR6S	3522		
V6LLGS	15		2	-		0,8	B6S	2319		
V6NGS	15		2	-		0,8	B6S	2319		

WIZARD

WD3	3,2			-		0,6	B6S	3510		
WD3S	3,2			-		0,6	B6S	3510		
WH6	5			-		0,6	B6S	3510		
WH6-1	5			-		0,6	B6S	3510		

	HP	c m	C y l					Stock-Nº		Stock-NºX		
WH6A	5			-				0,6	B6S	3510		
OC575	5,5			-				0,8	B6S	3510		
OC585	5,5			-				0,8	B6S	3510		
WD4	6			-				0,6	B6S	3510		
WD4S	6			-				0,6	B6S	3510		
WF4	6			-				0,6	B6S	3510		
WG4	6			-				0,6	B6S	3510		
WF7	10			-				0,6	B6S	3510		
WG7	10			-				0,6	B6S	3510		
WG7A	10			-				0,6	B6S	3510		
WH7	10			-				0,6	B6S	3510		
WJ7	10			-				0,6	B6S	3510		
WK7	10			-				0,6	B6S	3510		
WM7	10			-				0,6	B6S	3510		
WM7A	10			-				0,6	B6S	3510		
WN7	10			-				0,6	B6S	3510		
WN7A	10			-				0,6	B6S	3510		
OC1575	15			-				0,8	B-6L	3212		
OC1585	15			-				0,8	B-6L	3212		
WA25	25			-				0,6	B6S	3510		
WA25E	25			-				0,6	B6S	3510		
OC3585	35			-				0,8	AB-7	3010		

YAMAHA

V6 Excel			6	1987-1989				1,0	BR9HS-10	4551		
2B	2	43	1	-				0,7	BR5HS	3722		
2C	2	50	1	1995-				0,6	BR7HS	4122	BR7HIX	7067
F2.5A	2,5		1	-				0,6	BR6HS	3922	BR6HIX	3419
F2.5	2,5		1	2003-2005				0,6	BR6HS	3922	BR6HIX	3419
F2.5 MSH	2,5		1	2006-2010				0,6	BR6HS	3922	BR6HIX	3419
3A	3	83	1	-				1,0	BR6HS-10	1090		
4A	4		1	-				0,6	BR7HS	4122	BR7HIX	7067
4AC	4		1	-				0,6	BR7HS	4122	BR7HIX	7067
4AS	4		1	-				0,6	BR7HS	4122	BR7HIX	7067
4BC	4		1	-				0,6	BR7HS	4122	BR7HIX	7067
F4	4		1	1999-2005				0,6	BR6HS	3922	BR6HIX	3419
F4A	4	112	1	2003-				0,7	BR6HS	3922	BR6HIX	3419
F4B	4	139	1	2010-				0,7	CR6HSB	6500		
5C	5		1	-				0,6	BR7HS	4122	BR7HIX	7067
5CS	5		1	-				0,6	BR7HS	4122	BR7HIX	7067
F5A	5	139	1	2010-				0,7	CR6HSB	6500		
6D	6	165	1	1986-2007				1,0	B6HS-10	1052		
F6B	6	197	1	2000-2006				1,0	BR6HS-10	1090		
F6	6		1	2001-2005	OHV			1,0	BR6HS-10	1090		
F6A	6		1	2006-2010				1,0	BR6HS-10	1090		
F6M	6		1	2006-2010				1,0	BR6HS-10	1090		
F6C	6	139	1	2010-				1,0	BR6HS-10	1090		
F6 CMHS	6		1	-				1,0	BR6HS-10	1090		
8C	8		1	1986-				1,0	BR7HS-10	1098		
E8D Enduro	8	165	2	1986-				1,0	B7HS-10	2129		
F8A	8		2	1986-				0,9	CR5HSA	7840		
F8AEM	8		2	1986-				0,9	CR5HSA	7840		



HP







c
c
mC
y
l

Stock-Nº

FRIDIUM

Stock-NºX

	HP	c c m	C y l				Stock-Nº	FRIDIUM	Stock-NºX
F8AM	8		2	1986-		0,9	CR5HSA	7840	
F8B	8		2	1986-		0,9	CR5HSA	7840	
F8BE	8		2	1986-		0,9	CR5HSA	7840	
F8BM	8		2	1986-		0,9	CR5HSA	7840	
EK8D Enduro	8	165	2	1988-		0,7	B6HS	4510	BR6HIX 3419
F8	8		2	2001-2005	OHV	1,0	BR6HS-10	1090	
FT8D	8	197	2	2001-		1,0	BR6HS-10	1090	
T8	8		2	2001-2005	High Thrust, OHV	1,0	BR6HS-10	1090	
8MSH	8		2	2006-2010		1,0	B7HS-10	2129	
F8C	8		2	2006-2010		1,0	BR6HS-10	1090	
F8M	8		2	2006-2010		1,0	BR6HS-10	1090	
T8	8		2	2006-2010		1,0	BR6HS-10	1090	
9,9	9		2	1984-2005		1,0	B7HS-10	2129	
F9.9	9		2	1985-2004	Standard, OHC	0,6	CR6HS	7023	CR6HIX 7274
F9.9	9		2	2005-	Standard, OHC	0,9	DPR6EA-9	5531	
F9.9	9		2	1985-2004	Climat Froid / Standard, OHC	0,6			CR6HIX 7274
FT9.9	9		2	1985-2004	Standard, OHC	0,6	CR6HS	7023	CR6HIX 7274
FT9.9	9		2	2005-	Standard, OHC	0,9	DPR6EA-9	5531	
FT9.9	9		2	1985-2004	Climat Froid / Standard, OHC	0,6			CR6HIX 7274
T9.9	9		2	1985-2004	High Thrust, OHC	0,6	CR6HS	7023	CR6HIX 7274
T9.9	9		2	2005-	High Thrust, OHC	0,9	DPR6EA-9	5531	
T9.9	9		2	1985-2004	Climat Froid / Standard, OHC	0,6			CR6HIX 7274
9.9D	9,9	246	2	-1995		1,0	B7HS-10	2129	
9.9D	9,9		2	2005-		1,0	B7HS-10	2129	
9.9F	9,9	246	2	1996-		1,0	B7HS-10	2129	
E9.9B Enduro	9,9	246	2	1988-1996		1,0	B7HS-10	2129	
F9.9B	9,9	232	2	1991-2007		0,7	CR6HSA	2983	CR6HIX 7274
F9.9G	9,9		2	-		1,0	BR6HS-10	1090	
E9.9C Enduro	9,9	246	2	1997-2002		1,0	B7HS-10	2129	
F9.9C	9,9	323	2	1998-2008		0,9	DPR6EA-9	5531	
FT9.9A	9,9	232	2	1998-2007		0,7	CR6HSA	2983	CR6HIX 7274
E9.9D Enduro	9,9	246	2	2002-		1,0	B8HS-10	5126	
EK9.9D Enduro	9,9	246	2	2003-		1,0	B7HS-10	2129	
EK9.9H Enduro	9,9	246	2	2003-2004		1,0	B7HS-10	2129	
F9.9D	9,9		2	2005-		0,9	CR6HSA	2983	CR6HIX 7274
EK9.9J Enduro	9,9	246	2	2003-		1,0	B7HS-10	2129	
FT9.9D	9,9	323	2	2003-2006		0,9	DPR6EA-9	5531	
9.9MSH	9,9		2	2006-2010		1,0	B7HS-10	2129	
F9.9ELR	9,9		2	2006-2010		0,9	CR6HSA	2983	CR6HIX 7274
F9.9MLH	9,9		2	2006-2010		0,9	CR6HSA	2983	CR6HIX 7274
F9.9F	9,9	212	2	2006-2010		1,0	BR6HS-10	1090	
F9.9MSH	9,9		2	2006-2010		0,9	CR6HSA	2983	CR6HIX 7274
F9.9ELR2	9,9		2	2006-2010		0,9	DPR6EA-9	5531	
F9.9ELR2K	9,9		2	2006-2010		0,9	DPR6EA-9	5531	
F9.9MLH2	9,9		2	2006-2010		0,9	DPR6EA-9	5531	
F9.9MLH2K	9,9		2	2006-2010		0,9	DPR6EA-9	5531	
F9.9MSH2	9,9		2	2006-2010		0,9	DPR6EA-9	5531	
F9.9MSH2K	9,9		2	2006-2010		0,9	DPR6EA-9	5531	
T9.9ELH	9,9		2	2006-2010		0,9	CR6HSA	2983	CR6HIX 7274
FT9.9G	9,9	212	2	2007-		1,0	BR6HS-10	1090	
T9.9D	9,9		2	2005-		0,9	CR6HSA	2983	CR6HIX 7274
T9.9ELR	9,9		2	2006-2010		0,9	CR6HSA	2983	CR6HIX 7274
T9.9EXH	9,9		2	2006-2010		0,9	CR6HSA	2983	CR6HIX 7274

	HP	c c m	C y l					Stock-Nº		Stock-NºX
T9.9ELH2	9,9		2	2006-2010		0,9	DPR6EA-9	5531		
T9.9ELH2K	9,9		2	2006-2010		0,9	DPR6EA-9	5531		
T9.9ELR2	9,9		2	2006-2010		0,9	DPR6EA-9	5531		
T9.9ELR2K	9,9		2	2006-2010		0,9	DPR6EA-9	5531		
T9.9EXH2	9,9		2	2006-2010		0,9	DPR6EA-9	5531		
T9.9EXH2K	9,9		2	2006-2010		0,9	DPR6EA-9	5531		
F9.9H	9,9	362	2	2009-		0,9	DPR6EB-9	3108		
F13.5A	13,5	323	2	2001-2007		0,9	DPR6EA-9	5531		
F13.5B	13,5	362	2	2007-2009		0,9	DPR6EB-9	3108		
E15B Enduro	15	246	2	1988-1996		1,0	B7HS-10	2129		
15F	15	246	2	1996-		1,0	B7HS-10	2129		
EK15H Enduro	15	246	2	1989-1996		1,0	B7HS-10	2129		
EK15J Enduro	15	246	2	1989-1996		1,0	B7HS-10	2129		
EK15N Enduro	15	246	2	1994-2004		1,0	B7HS-10	2129		
E15C Enduro	15	246	2	1997-2002		1,0	B7HS-10	2129		
15D	15	246	2	-1995		1,0	B7HS-10	2129		
E15D Enduro	15	246	2	2002-		1,0	B7HS-10	2129		
EK15D Enduro	15	246	2	2003-		1,0	B7HS-10	2129		
EK15P Enduro	15	246	2	2003-		1,0	B7HS-10	2129		
15MSH	15		2	2006-2010		1,0	B7HS-10	2129		
F15	15		2	1998-2004		0,9	DPR6EA-9	5531		
F15A	15	323	2	2003-2006		0,9	DPR6EA-9	5531		
F15B	15	323	2	2003-2008		0,9	DPR6EA-9	5531		
F15C	15	362	2	2006-2010		0,9	DPR6EB-9	3108		
F15E	15		2	2006-2010		0,9	DPR6EA-9	5531		
F15M	15		2	2006-2010		0,9	DPR6EA-9	5531		
F15P	15		2	2006-2010		0,9	DPR6EA-9	5531		
20C	20	430	2	1996-2007		0,6	BR7HS	4122	BR7HIX	7067
20D	20	395	2	1988-		1,0	B7HS-10	2129		
EK20F Enduro	20	430	2	-1993		0,7	B6HS	4510	BR6HIX	3419
F20A	20	498		1998-2009		0,9	DPR6EA-9	5531		
F20	20			2006-2010		0,9	DPR6EB-9	3108		
F20B	20	362	2	2006-		0,9	DPR6EB-9	3108		
F20C	20	362		2008-		0,9	DPR6EB-9	3108		
F20D	20	498		2011-		0,9	DPR6EB-9	3108		
25J	25			1987-2003		1,0	B7HS-10	2129		
25B	25	496	2	2007-		1,0	B7HS-10	2129		
25C	25		2	1990-1997		0,6	B7HS	5110	BR7HIX	7067
25D	25	430		1990-2003		0,7	B7HS	5110	BR7HIX	7067
25V	25			1992-2001		1,0	B7HS-10	2129		
25N	25	395	2	1988-		1,0	B7HS-10	2129		
FT25B	25	498		2000-2009		0,9	DPR6EA-9	5531		
25X	25			2001-		1,0	B8HS-10	5126		
25Q	25			-1995		1,0	B7HS-10	2129		
E25B Enduro	25	496		2001-		1,0	B7HS-10	2129		
E25A Enduro	25	496		-2001		1,0	B7HS-10	2129		
E25F Enduro	25	430		-1993		0,7	B7HS	5110	BR7HIX	7067
EK25F Enduro	25	430		-1993		0,7	B7HS	5110	BR7HIX	7067
EK25B Enduro	25	496		2003-		1,0	B7HS-10	2129		
25	25			2006-2010		1,0	B7HS-10	2129		
F25	25		2	1998-2005	OHC	0,9	DPR6EA-9	5531		
F25A	25	498	2	2003-		0,9	DPR6EA-9	5531		
F25C	25	498	2	2003-2009		0,9	DPR6EA-9	5531		



HP







c
mC
Y
I

Stock-No



Stock-NoX

F25D	25	498	2	2010-		0,9	DPR6EB-9	3108		
EK25C Enduro	25	496		2006-		1,0	B7HS-10	2129		
F25E	25			2006-2010		0,9	DPR6EA-9	5531		
F25M	25			2006-2010		0,9	DPR6EA-9	5531		
F25T	25			2006-2010		0,9	DPR6EA-9	5531		
F25L	25			2006-2010		0,9	DPR6EB-9	3108		
F25S	25			2006-2010		0,9	DPR6EB-9	3108		
FT25F	25	498	2	2009-		0,9	DPR6EB-9	3108		
T25	25		2	2001-2005	High Thrust, OHC	0,9	DPR6EA-9	5531		
T25LA	25			2006-2010		0,9	DPR6EB-9	3108		
T25TLR	25			2006-2010		0,9	DPR6EA-9	5531		
30G	30	496		1993-2001		1,0	B7HS-10	2129		
30C	30		2	1989-1992		0,6	B7HS	5110	BR7HIX	7067
30C	30		2	1993-1997		1,0	B8HS-10	5126		
30D	30	496	3	1986-		1,0	B7HS-10	2129		
F30	30			2001-2005	OHC	0,9	DPR6EA-9	5531		
30H Enduro	30	496	2	2001-		1,0	B8HS-10	5126		
E30H Enduro	30	496	2	2001-		1,0	B8HS-10	5126		
30A	30	496		-1992		0,7	B7HS	5110	BR7HIX	7067
F30A	30			-2002		0,9	DPR6EA-9	5531		
F30A	30	747	3	2003-2009		0,9	DPR6EA-9	5531		
F30B	30	747	3	2009-		0,9	DPR6EB-9	3108		
F30E	30			2006-		0,9	DPR6EA-9	5531		
F30T	30			2006-		0,9	DPR6EA-9	5531		
F30TLR	30			2006-2010		0,9	DPR6EA-9	5531		
40C	40		2	1989-1997		0,6	B8HS	5510	BR8HIX	7001
40C	40		3	1997-2002		1,0	B7HS-10	2129		
E40G Enduro	40	669		1982-		0,7	B7HS	5110	BR7HIX	7067
40J Enduro	40	669		1983-		0,7	B7HS	5110	BR7HIX	7067
E40J Enduro	40	669		1983-		0,7	B7HS	5110	BR7HIX	7067
EK40G Enduro	40	669		1998-		0,7	B7HS	5110	BR7HIX	7067
40V	40	698	3	1995-		1,0	B7HS-10	2129		
40X Enduro	40	703	2	1998-		0,7	B7HS	5110	BR7HIX	7067
EK40J Enduro	40	669		1998-		0,7	B7HS	5110	BR7HIX	7067
F40A	40	935		1998-2002		0,9	DPR6EA-9	5531		
F40C	40	996		2000-2007		0,9	DPR5EA-9	2887		
E40X Enduro	40	703	2	1998-		0,7	B7HS	5110	BR7HIX	7067
40Y	40	698		2001-		1,0	BR8HS-10	1134		
40H	40	698		-1994		1,0	B7HS-10	2129		
F40	40		3	2000-2005		0,9	DPR6EA-9	5531		
F40	40		4	1999-		0,9	DPR6EA9	5531		
40Q	40	592		-1998		0,7	B8HS	5510	BR8HIX	7001
F40B	40	747	3	2003-2009		0,9	DPR6EA-9	5531		
40TLR	40			2006-2010		1,0	B7HS-10	2129		
F40D	40	996		2006-		0,9	DPR6EB-9	3108		
F40E	40			2006-		0,9	DPR6EA-9	5531		
F40F	40	747	3	2009-	EFI	0,9	DPR6EB-9	3108		
F40J	40			2006-2010		0,9	DPR6EB-9	3108		
F40L	40			2006-2010		0,9	DPR6EB-9	3108		
F40T	40			2006-		0,9	DPR6EA-9	5531		
F40G	40	996		2011-		0,9	LKR7E	1643		
E48	48		2	1995-2000		0,6	B7HS	5110	BR7HIX	7067
E48C Enduro	48	760		1992-		0,7	B7HS	5110	BR7HIX	7067

	HP	ccm	Cyl					Stock-No		Stock-NrX
50EK Enduro	50	849		1988-1997			1,0	B8HS-10	5126	
50C	50		3	1998-			1,0	BR8HS-10	1134	
50C	50		3	1999-2001			0,6	B8HS	5510	BR8HIX 7001
50G	50	849		1993-2007			1,0	BR8HS-10	1134	
FT50B	50	935		1998-2006			0,9	DPR6EA-9	5531	
F50D	50	935		2001-			0,9	DPR6EA-9	5531	
50H	50	698	3	1995-			1,0	B8HS-10	5126	
F50	50		4	1995-2004	OHC		0,9	DPR6EA-9	5531	
F50	50		4	2005-	Standard, EFI OHC		0,9	DPR6EB-9	3108	
F50A	50	935	4	2003-2005			0,9	DPR6EA9	5531	
FT50C	50	935		2001-			0,9	DPR6EA-9	5531	
50D	50	698		-1994			1,0	B8HS-10	5126	
F50F	50	996	4	2004-	EFI		0,9	DPR6EB9	3108	
F50B	50			-2002			0,9	DPR6EA-9	5531	
FT50G	50	996		2005-			0,9	DPR6EB-9	3108	
50TLR	50			2006-2010			1,0	B8HS-10	5126	
F50TLR	50			2006-2010			0,9	DPR6EB-9	3108	
P50	50		3	1987-1996			1,0	BR8HS-10	1134	
T50	50		4	2005-	High Thrust, EFI OHC		0,9	DPR6EB-9	3108	
T50	50		4	1995-2004	High Thrust, OHC		0,9	DPR6EA-9	5531	
T50LRD	50		4	1996-2004	High Thrust, OHC		0,9	DPR6EB-9	3108	
T50TLR	50			2006-2010			0,9	DPR6EB-9	3108	
55B	55	760		1989-			1,0	B8HS-10	5126	
55C	55		2	1989-1995			1,0	B8HS-10	5126	
E55C Enduro	55	760		1992-			0,7	B8HS	5510	BR8HIX 7001
55D	55	1140		1998-			1,0	B8HS-10	5126	
E60J Enduro	60	1140		1995-			1,0	B8HS-10	5126	
60C	60		3	1996-2002			1,0	B8HS-10	5126	
60F	60	849	3	1992-			1,0	B8HS-10	5126	
T60	60			2003-2004			0,9	DPR5EA-9	2887	
E60	60		3	1995-2000			1,0	B8HS-10	5126	
E60H Enduro	60	849	3	1986-			1,0	B8HS-10	5126	
F60A	60	996	4	2003-2005			0,9	DPR5EA9	2887	
F60C	60		4	2004-	EFI		0,9	DPR6EB9	3108	
T60	60			2005-	EFI		0,9	DPR6EB-9	3108	
60TLR	60			2006-2010			1,0	B8HS-10	5126	
FT60B	60	996	4	2002-2007			0,9	DPR5EA9	2887	
FT60D	60	996	4	2007-	EFI		0,9	DPR6EB9	3108	
P60	60		3	1991-1999			1,0	B8HS-10	5126	
F60TJR	60			2006-2010			0,9	DPR6EB-9	3108	
F60TLR	60			2006-2010			0,9	DPR6EB-9	3108	
T60TLR	60			2006-2010			0,9	DPR6EB-9	3108	
E65A Enduro	65	1140		1998-			1,0	BR8HS-10	1134	
70B	70	849	3	1992-			1,0	B8HS-10	5126	
70C	70	847	3	1992-2001			1,0	B8HS-10	5126	
70LTR	70			2006-2010			1,0	B8HS-10	5126	
F70A	70	996		2011-			0,9	LKR7E	1643	
75A	75	1140	3	1994-2004			1,0	B8HS-10	5126	
75C	75	1140	3	1996-			1,0	B8HS-10	5126	
E75	75		3	1995-2000			1,0	B8HS-10	5126	
E75B Enduro	75	1140		1991-			1,0	B8HS-10	5126	
F75A	75	1596		2002-2004			1,1	LFR5A-11	6376	LFR5AIX-11 4469
F75B	75	1596		2005-			1,1	LFR5A-11	6376	LFR5AIX-11 4469



HP







c
mC
y
l

Stock-Nr

FRIDUM

Stock-NrX

F75TLR	75	1596		2006-2010		1,1	LFR5A-11	6376	LFR5AIX-11	4469
P75	75		3	1996-1999		1,0	B8HS-10	5126		
80A	80	1140		1992-2003		1,0	B8HS-10	5126		
80C	80		3	1997-		1,0	B8HS-10	5126		
F80	80		3	1999-2002		1,1	LFR5A-11	6376	LFR5AIX-11	4469
F80A	80	1596	4	2003-2005		1,1	LFR5A11	6376	LFR5AIX11	4469
F80B	80	1596	4	2004-	EFI	1,1	LFR5A11	6376	LFR5AIX11	4469
F80C	80	1596	4	2009-		1,1	LFR5A11	6376	LFR5AIX11	4469
85A	85	1140	3	1989-2004		1,0	B8HS-10	5126		
85C	85		3	1989-1996		1,0	B8HS-10	5126		
90A	90	1140	3	1992-		1,0	B8HS-10	5126		
90B	90		3	1998-1999		1,0	B8HS-10	5126		
90C	90		3	1997-2001		1,0	B8HS-10	5126		
F90A	90	1596		2002-2004		1,1	LFR5A-11	6376	LFR5AIX-11	4469
F90	90			2003-2005		1,1	LFR5A-11	6376	LFR5AIX-11	4469
F90B	90	1596		2005-		1,1	LFR5A-11	6376	LFR5AIX-11	4469
90TLR	90			2006-2010		1,0	B8HS-10	5126		
F90TJR	90			2006-2010		1,1	LFR5A-11	6376	LFR5AIX-11	4469
F90TLR	90			2006-2010		1,1	LFR5A-11	6376	LFR5AIX-11	4469
F90TXR	90			2006-2010		1,1	LFR5A-11	6376	LFR5AIX-11	4469
100A	100	1730		1996-2001		1,0	B8HS-10	5126		
F100	100			1999-2002		1,1	LFR5A-11	6376	LFR5AIX-11	4469
F100A	100	1596	4	1999-2005		1,1	LFR5A11	6376	LFR5AIX11	4469
F100B	100	1596	4	2002-		1,1	LFR5A11	6376	LFR5AIX11	4469
F100C	100	1596	4	2002-2007		1,1	LFR5A11	6376	LFR5AIX11	4469
F100C	100	1596	4	2005-	EFI	1,1	LFR5A11	6376	LFR5AIX11	4469
115	115	1700	4	1984-2005		1,0	BR8HS-10	1134		
P115	115	1700	4	1984-2005		1,0	BR8HS-10	1134		
115B	115	1700	4	1998-1999		1,0	BR8HS-10	1134		
115C	115	1700	4	1991-2000		1,0	BR8HS-10	1134		
115TJR	115	1700	4	1987-1997		1,0	BR8HS-10	1134		
LF115	115	1700		2000-2005		1,1	LFR6A-11	3672	LFR6AIX-11	6619
VL115	115			-		0,9	LKR6E	92650		
E115A Enduro	115	1730	4	1992-		1,0	B8HS-10	5126		
F115	115	1700	4	2000-2005		1,1	LFR6A-11	3672	LFR6AIX-11	6619
F115	115	1700	4	2000-2005		1,1	LFR6A-11	3672	LFR6AIX-11	6619
115TLR	115			2006-2010		1,0	BR8HS-10	1134		
115TXR	115			2006-2010		1,0	BR8HS-10	1134		
F115TJR	115			2006-2010		1,1	LFR6A-11	3672	LFR6AIX-11	6619
F115TLR	115			2006-2010		1,1	LFR6A-11	3672	LFR6AIX-11	6619
F115TXR	115			2006-2010		1,1	LFR6A-11	3672	LFR6AIX-11	6619
LF115TXR	115			2006-2010		1,1	LFR6A-11	3672	LFR6AIX-11	6619
FL115A	115	1741	4	2000-	EFI	1,1	LFR6A-11	3672	LFR6AIX-11	6619
LF115	115	1700	4	2000-2005		1,1	LFR6A-11	3672	LFR6AIX-11	6619
F115LB	115			2014-		0,9	LKR6E	92650		
F115JB	115			2014-		0,9	LKR6E	92650		
F115 XB	115			2014-		0,9	LKR6E	92650		
P115	115	1700	4	1993-1996		1,0	BR8HS-10	1134		
S115	115	1700	4	1984-1999		1,0	BR8HS-10	1134		
LF115 XB	115			2014-		0,9	LKR6E	92650		
130	130	1700	4	1988-2004		1,0	BR9HS-10	4551		
130B	130	1700	4	1991-		1,0	BR9HS-10	4551		
L130	130	1700	4	1989-2001		1,0	BR9HS-10	4551		

	HP	c c m	C y l					Stock-Nr		Stock-NrX
L130B	130	1700	4	1991 -		1,0	BR9HS-10	4551		
S130	130	1700	4	1988 - 1999		1,0	BR9HS-10	4551		
140B	140	1730		1992 -		1,0	B9HS-10	3626		
140C	140	1730		1993 - 2003		1,0	B9HS-10	3626		
150	150	2600	6	1984 - 1987		1,0	BR7HS-10	1098		
150	150	2600	6	1988 - 1995		1,0	BR8HS-10	1134		
150	150	2600	6	1996 - 2004		1,0	BR7HS-10	1098		
150A	150	2596		1983 -		1,0	B8HS-10	5126		
L150A	150	2596		1983 -		1,0	B8HS-10	5126		
150C	150	2600	6	1996 -		1,0	BR7HS-10	1098		
150C	150	2600	6	1997 - 1999		1,0	BR8HS-10	1134		
150C	150	2596		1990 - 1995		1,0	B8HS-10	5126		
150F	150	2596	6	1996 -		1,0	BR7HS-10	1098		
150G	150	2596	6	1996 -		1,0	BR7HS-10	1098		
150J	150	2596	6	2000 - 2006		1,0	BR7HS-10	1098		
150L	150	2596	6	2000 - 2005		1,0	BR7HS-10	1098		
150TJR	150	2600	6	1996 - 1997		1,0	BR7HS-10	1098		
L150C	150	2596		1990 - 1995		1,0	B8HS-10	5126		
D150	150	2600	6	1997 - 1999		1,0	BR8HS-10	1134		
D150H	150	2596	6	1998 - 2003		1,0	BR8HS-10	1134		
D150N	150	2596	6	2000 - 2005		1,0	BR7HS-10	1098		
D150	150	2600	6	1986 - 1993	Twin Prop	1,0	B8HS-10	5126		
DX150	150	2600	6	1999 - 2005		1,0	BR7HS-10	1098		
150D	150	2596		1991 - 1995		1,0	B8HS-10	5126		
F150A	150	2670	4	2003 -	EFI	1,1	LFR5A11	6376	LFR5AIX11	4469
F150B	150	2670	4	2009 -	EFI	1,1	LFR5A11	6376	LFR5AIX11	4469
LZ150TX	150			2000 - 2001	HPDI / ->800554	1,1	BKR6ES-11	5553	BKR6EIX-11	3764
VZ150T	150			2000 - 2001	HPDI / ->800711	1,1	BKR6ES-11	5553	BKR6EIX-11	3764
Z150TL	150			2000 - 2001	HPDI (->800452)	1,1	BKR6ES-11	5553	BKR6EIX-11	3764
FL150A	150	2670	4	2004 -	EFI	1,1	LFR5A11	6376	LFR5AIX11	4469
FL150B	150	2670	4	2009 -	EFI	1,1	LFR5A11	6376	LFR5AIX11	4469
L150	150	2600	6	1986 - 1987		1,0	BR7HS-10	1098		
L150	150	2600	6	1988 - 1995		1,0	BR8HS-10	1134		
Z150TX	150			2000 - 2001	HPDI (->851535)	1,1	BKR6ES-11	5553	BKR6EIX-11	3764
LZ150TX	150			2001 -	HPDI / 800555->	-	BKR6EKU	6993		
L150F	150	2596	6	1996 -		1,0	BR7HS-10	1098		
L150J	150	2596	6	2000 - 2006		1,0	BR7HS-10	1098		
LF150	150	2600	6	2004 - 2005		1,1	LFR5A-11	6376	LFR5AIX-11	4469
VZ150T	150			2001 -	HPDI / 800712->	-	BKR6EKU	6993		
LX150	150	2600	6	1999 - 2004		0,6	BR7HS	4122	BR7HIX	7067
LZ150	150	2600	6	2002 - 2005		-	BKR6EKU	6993		
LZ150P	150	2596	6	2000 -	DFI	1,6	BKR6EKU	6993		
Z150TL	150			2001 -	HPDI (800453-->)	-	BKR6EKU	6993		
Z150TX	150			2001 -	HPDI (851536-->)	-	BKR6EKU	6993		
VZ150	150			2002 - 2005	HPDI	-	BKR6EKU	6993		
P150	150	2600	6	1986 - 1995		1,0	BR8HS-10	1134		
P150	150	2600	6	1996 - 1999		1,0	BR7HS-10	1098		
PX150	150	2600	6	1999 -		0,6	BR7HS	4122	BR7HIX	7067
S150	150	2600	6	1994 - 1999		1,0	BR7HS-10	1098		
S150F	150	2596	6	1997 -		1,0	BR7HS-10	1098		
SL150F	150	2596	6	1997 -		1,0	BR7HS-10	1098		
SX150	150	2600	6	1999 - 2004		1,0	BR7HS-10	1098		
V150	150	2600	6	1999 - 2005		1,0	BR7HS-10	1098		



HP







c
c
mC
y
l

Stock-Nr

FRIDUM

Stock-NrX

Z150TL	150			2002-2005		-	BKR6EKU	6993		
VX150	150		6	2000-2005		1,0	BR7HS-10	1098		
F150	150			2004-2005		1,1	LFR5A-11	6376	LFR5AIX-11	4469
150TXR	150			2006-2010		1,0	BR7HS-10	1098		
F150TJR	150			2006-2010		1,1	LFR5A-11	6376	LFR5AIX-11	4469
F150TLR	150			2006-2010		1,1	LFR5A-11	6376	LFR5AIX-11	4469
Z150P	150	2596	6	2000-	DFI	1,6	BKR6EKU	6993		
Z150Q	150	2596	6	2000-		1,6	BKR6EKU	6993		
F150TXR	150			2006-2010		1,1	LFR5A-11	6376	LFR5AIX-11	4469
LF150TXR	150			2006-2010		1,1	LFR5A-11	6376	LFR5AIX-11	4469
LZ150TXR	150			2006-2010		-	BKR6EKU	6993		
V150TLR	150			2006-2010		1,0	BR7HS-10	1098		
VZ150TLR	150			2006-2010		-	BKR6EKU	6993		
Z150TXR	150			2006-2010		-	BKR6EKU	6993		
175A	175	2596	6	1983-2008		1,0	B8HS-10	5126		
175B	175	2596	6	1990-1995		1,0	B8HS-10	5126		
175C	175	2596	6	1991-1995		1,0	B8HS-10	5126		
175D	175	2596	6	1996-2006		1,0	BR8HS-10	1134		
175F	175	2596	6	1996-2005		1,0	BR8HS-10	1134		
P175	175	2600	6	1994-1999		1,0	BR8HS-10	1134		
P175	175	2600	6	1994-1999		1,0	BR8HS-10	1134		
S175	175	2600	6	1994-1999		1,0	BR8HS-10	1134		
T175	175	2600	6	1994-1999		1,0	BR8HS-10	1134		
S175	175	2600	6	1999-		1,0	BR8HS-10	1134		
S175D	175	2596	6	1997-		1,0	BR8HS-10	1134		
V175	175	2600	6	2000-		1,0	BR8HS-10	1134		
VZ175TL	175			2001-	800105--> 800201 / HPDI	1,1	BKR7ES-11	2387	BKR7EIX-11	6988
VZ175TL	175			2001-	800202--> / HPDI	-	BKR7EKU	5881		
Z175H	175	2596		2001-		1,6	BKR7EKU	5881		
Z175TX	175			2001-	800101-->800231 / HPDI	1,1	BKR7ES-11	2387	BKR7EIX-11	6988
Z175TX	175			2001-	800232--> /HPDI	-	BKR7EKU	5881		
Z175G	175	2596	6	2000-	DFI	1,6	BKR7EKU	5881		
VZ175	175			2002-2005	HPDI	-	BKR7EKU	5881		
Z175	175			2002-2005	HPDI	-	BKR7EKU	5881		
VZ175TLR	175			2006-2010		-	BKR7EKU	5881		
Z175TXR	175			2006-2010		-	BKR7EKU	5881		
200	200	2600	6	1984-1999		1,0	BR8HS-10	1134		
L200	200	2600	6	1984-1999		1,0	BR8HS-10	1134		
S200	200	2600	6	1984-1999		1,0	BR8HS-10	1134		
200A	200	2596	6	1983-		1,0	B8HS-10	5126		
200B	200	2596	6	1990-1995		1,0	B8HS-10	5126		
200C	200	2596	6	1991-1995		1,0	B8HS-10	5126		
200F	200	2596	6	1996-		1,0	BR8HS-10	1134		
200G	200	2596	6	1996-		1,0	BR8HS-10	1134		
200H	200	2596	6	1998-2005		1,0	BR8HS-10	1134		
200J	200	2596	6	2000-2005		1,0	BR8HS-10	1134		
200TJR	200	2600	6	1987-1995		1,0	BR8HS-10	1134		
LZ200TX	200			2000-2001	>100874 / HPDI	1,1	BKR7ES-11	2387	BKR7EIX-11	6988
F200A	200	3352	6	2002-		1,1	LFR5A-11	6376	LFR5AIX-11	4469
F200B	200	3352	6	2007-		1,1	LFR5A-11	6376	LFR5AIX-11	4469
F200C	200	3352	6	2007-		1,1	LFR6A-11	3672	LFR6AIX-11	6619
F200D	200	4169	6	2010-	MPFI	1,1	LFR6A-11	3672	LFR6AIX-11	6619
Z200TL	200			2000-2001	>150689 / HPDI	1,1	BKR7ES-11	2387	BKR7EIX-11	6988

	HP	c c m	C y l					Stock-No		Stock-NrX
FL200A	200	3352	6	2002-	EFI	1,1	LFR5A-11	6376	LFR5AIX-11	4469
FL200B	200	3352	6	2007-	EFI	1,1	LFR5A-11	6376	LFR5AIX-11	4469
FL200C	200	3352	6	2007-	EFI	1,1	LFR6A-11	3672	LFR6AIX-11	6619
L200A	200	2596	6	1983-		1,0	BR8HS-10	5126		
L200B	200	2596	6	1990-1995		1,0	BR8HS-10	5126		
L200F	200	2596	6	1996-		1,0	BR8HS-10	1134		
L200J	200	2596	6	2000-2005		1,0	BR8HS-10	1134		
Z200TX	200			2000-2001	>102420 / HPDI	1,1	BKR7ES-11	2387	BKR7EIX-11	6988
LZ200TX	200			2001-	100875--> / HPDI	-	BKR7EKU	5881		
LX200	200	2600	6	1999-2001		1,0	BR8HS-10	1134		
Z200TL	200			2001-	150690--> / HPDI	-	BKR7EKU	5881		
LZ200N	200	2596	6	2000-	DFI	1,6	BKR7EKU	5881		
Z200TX	200			2001-	102421--> / HPDI	-	BKR7EKU	5881		
F200	200			2002-2005		1,1	LFR5A-11	6376	LFR5AIX-11	4469
LF200	200			2002-2005		1,1	LFR5A-11	6376	LFR5AIX-11	4469
P200	200	2600	6	1991-1995		1,0	BR9HS-10	4551		
P200	200	2600	6	1996-1999		1,0	BR8HS-10	1134		
S200F	200	2596	6	1997-2003		1,0	BR8HS-10	1134		
SL200F	200	2596	6	1997-2003		1,0	BR8HS-10	1134		
SX200	200	2600	6	1999-2005		1,0	BR8HS-10	1134		
V200 V760	200	2600	6	1998-1999	EFI	1,0	BR8HS-10	1134		
VX200	200	3100	6	2000-2005		1,0	BR8HS-10	1134		
VX200D	200	3300	6	2005-		1,0	BR8HS-10	1134		
VZ200	200	2600	6	2000-2004		-	BKR7EKU	5881		
VZ200	200	3300	6	2005-		-	BKR6EKU	6993		
LZ200	200			2002-2005		-	BKR7EKU	5881		
Z200	200			2002-2005		1,0	BKR7EKU	5881		
F200TXR	200			2006-2010		1,1	LFR5A-11	6376	LFR5AIX-11	4469
Z200N	200	2596	6	2000-	DFI	1,6	BKR7EKU	5881		
Z200P	200	2596	6	2001-		1,6	BKR7EKU	5881		
Z200Q	200	2596	6	2005-2007		1,6	BKR7EKU	5881		
Z200R	200	3342	6	2005-		1,6	BKR6EKU	6993		
LF200TXR	200			2006-2010		1,1	LFR5A-11	6376	LFR5AIX-11	4469
LZ200TXR	200			2006-2010		-	BKR7EKU	5881		
VZ200RTL	200			2006-2010		-	BKR6EKU	6993		
VZ200TLR	200			2006-2010		-	BKR6EKU	6993		
Z200TLR	200			2006-2010		-	BKR7EKU	5881		
Z200TXR	200			2006-2010		-	BKR7EKU	5881		
2220 Special	220		6	1984-1986		1,0	BR8HS-10	1134		
225	225	2600	6	1987-1995	Excel Resistor required	1,0	BR9HS-10	4551		
225C	225	3130		1994-2004		1,0	BR9HS-10	4551		
L225	225			1994-1995		1,0	BR8HS-10	1134		
225D	225	2596		1996-		1,0	BR8HS-10	1134		
225F	225	3130		1997-2006	EFI	1,0	BR9HS-10	4551		
225G	225	3130		1998-2004		1,0	BR9HS-10	4551		
225L	225	2600	6	1994-1998	20" Shaft only	1,0	BR8HS-10	1134		
225X	225	3100	6	1994-1999		1,0	BR9HS-10	4551		
F225	225			2002-2005		1,1	LFR5A-11	6376	LFR5AIX-11	4469
F225A	225	3352	6	2002-2010	EFI	1,1	LFR5A-11	6376	LFR5AIX-11	4469
F225B	225	3352	6	2007-	EFI	1,1	LFR6A-11	3672	LFR6AIX-11	6619
F225C	225	3352	6	2008-	EFI	1,1	LFR6A-11	3672	LFR6AIX-11	6619
F225D	225	4169	6	2010-	MPFI	1,1	LFR6A-11	3672	LFR6AIX-11	6619
F225F	225	4169	6	2010-	EFI	1,1	LFR6A-11	3672	LFR6AIX-11	6619



HP







c
c
mC
y
l

Stock-Nr

FRIDUM

Stock-NrX

LF225	225			2002-2005		1,1	LFR5A-11	6376	LFR5AIX-11	4469
LX225	225			2002-2003		1,1	LFR5A-11	6376	LFR5AIX-11	4469
VZ225	225			2003-2004		-	BKR6EKU	6993		
FL225A	225	3352	6	2002-2010	EFI	1,1	LFR5A-11	6376	LFR5AIX-11	4469
FL225B	225	3352	6	2007-		1,1	LFR6A-11	3672	LFR6AIX-11	6619
FL225F	225	4169	6	2010-	EFI	1,1	LFR6A-11	3672	LFR6AIX-11	6619
Z225H	225	3342		2004-		1,6	BKR6EKU	6993		
L225	225	3100	6	1994-1999		1,0	BR9HS-10	4551		
L225C	225	3130	6	1994-2004		1,0	BR9HS-10	4551		
L225F	225	3130	6	1997-2006	EFI	1,0	BR9HS-10	4551		
225B	225	2596		-1995		1,0	BR9HS-10	4551		
F225TLR	225			2006-2010		1,1	LFR6A-11	3672	LFR6AIX-11	6619
F225TUR	225			2006-2010		1,1	LFR5A-11	6376	LFR5AIX-11	4469
F225TXR	225			2006-2010		1,1	LFR5A-11	6376	LFR5AIX-11	4469
LX225	225	3100	6	1997-2002		1,0	BR9HS-10	4551		
S225	225	3100	6	1994-1999		1,0	BR9HS-10	4551		
SX225	225	3100	6	1997-2002		1,0	BR9HS-10	4551		
V225 V760	225	3100	6	1997-2001	EFI	1,0	BR9HS-10	4551		
VX225 V760	225	3100	6	1997-2004	EFI	1,0	BR9HS-10	4551		
LF225TUR	225			2006-2010		1,1	LFR5A-11	6376	LFR5AIX-11	4469
LF225TXR	225			2006-2010		1,1	LFR5A-11	6376	LFR5AIX-11	4469
VZ225HTLR	225			2006-2010		-	BKR6EKU	6993		
VZ225TLR	225			2006-2010		-	BKR6EKU	6993		
250	250	3100	6	1990-1995		1,0	BR8HS-10	1134		
L250	250	3100	6	1990-1995		1,0	BR8HS-10	1134		
250A	250	3130	6	1990-1996		1,0	BR8HS-10	1134		
250B	250	3130	6	1997-2006	EFI	1,0	BR9HS-10	4551		
250C	250	3130	6	2003-2004		1,0	BR9HS-10	4551		
250G	250	3130	6	2006-		1,0	BR8HS-10	1134		
SL250A	250	3130		1997-2006		1,0	BR9HS-10	4551		
F250A	250	3352	6	2005-	EFI	1,1	LFR6A-11	3672	LFR6AIX-11	6619
F250B	250	3352	6	2008-2010	EFI	1,1	LFR6A-11	3672	LFR6AIX-11	6619
LZ250	250	3300		2003-2005		-	BKR6EKU	6993		
Z250	250	3300		2003-2005		-	BKR6EKU	6993		
F250C	250	4169	6	2010-	EFI	1,1	LFR6A-11	3672	LFR6AIX-11	6619
F250D	250	4169	6	2010-	EFI	1,1	LFR6A-11	3672	LFR6AIX-11	6619
F250G	250	3352	6	2012-	EFI	1,1	LFR6A-11	3672	LFR6AIX-11	6619
VZ250	250			2003-2005		-	BKR6EKU	6993		
F250	250			2005-		1,1	LFR5A-11	6376	LFR5AIX-11	4469
FL250A	250	3352	6	2005-	EFI	1,1	LFR6A-11	3672	LFR6AIX-11	6619
FL250B	250	3352	6	2008-2010	EFI	1,1	LFR6A-11	3672	LFR6AIX-11	6619
FL250D	250	4169	6	2010-	EFI	1,1	LFR6A-11	3672	LFR6AIX-11	6619
FL250G	250	3352	6	2012-	EFI	1,1	LFR6A-11	3672	LFR6AIX-11	6619
L250	250	3100	6	1997-1999		1,0	BR9HS-10	4551		
S250	250	3100	6	1997-1999		1,0	BR9HS-10	4551		
L250A	250	3130	6	1990-2006		1,0	BR8HS-10	1134		
L250B	250	3130	6	1997-2006	EFI	1,0	BR9HS-10	4551		
L250G	250	3130	6	2006-		1,0	BR8HS-10	1134		
LF250	250			2005-		1,1	LFR5A-11	6376	LFR5AIX-11	4469
F250BTUR	250			2006-2010		1,1	LFR6A-11	3672	LFR6AIX-11	6619
F250BTXR	250			2006-2010		1,1	LFR6A-11	3672	LFR6AIX-11	6619
F250TUR	250			2006-2010		1,1	LFR6A-11	3672	LFR6AIX-11	6619
F250TXR	250			2006-2010		1,1	LFR6A-11	3672	LFR6AIX-11	6619

	HP	c m	C y l					Stock-Nº			Stock-NºX
LX250	250	3100	6	1997-2003		1,0	BR9HS-10	4551			
LF250BTUR	250			2006-2010		1,1	LFR6A-11	3672	LFR6AIX-11	6619	
LF250BTXR	250			2006-2010		1,1	LFR6A-11	3672	LFR6AIX-11	6619	
LZ250D	250	3342	6	2002-2007	DFI	1,6	BKR6EKU	6993			
LF250TUR	250			2006-2010		1,1	LFR6A-11	3672	LFR6AIX-11	6619	
LF250TXR	250			2006-2010		1,1	LFR6A-11	3672	LFR6AIX-11	6619	
S250	250	3100	6	1990-1996		1,0	BR8HS-10	1134			
LZ250TUR	250			2006-2010		-	BKR6EKU	6993			
SX250	250	3100	6	1997-2003		1,0	BR9HS-10	4551			
VX250	250	3100	6	2002-2004		1,0	BR9HS-10	4551			
LZ250TXR	250			2006-2010		-	BKR6EKU	6993			
VZ250FTLR	250			2006-2010		-	BKR6EKU	6993			
VZ250TLR	250			2006-2010		-	BKR6EKU	6993			
Z250TUR	250			2006-2010		-	BKR6EKU	6993			
Z250TXR	250			2006-2010		-	BKR6EKU	6993			
F300A	300	5330	8	2008-	MPFI	1,1	LFR6A-11	3672	LFR6AIX-11	6619	
F300B	300	4169	6	2010-	EFI	1,1	LFR6A-11	3672	LFR6AIX-11	6619	
Z300B	300	3352		2003-		1,6	BKR6EKU	6993			
LX300	300	3300		2004-2005		-	BKR6EKU	6993			
FL300A	300	5330	8	2011-	MPFI	1,1	LFR6A-11	3672	LFR6AIX-11	6619	
FL300B	300	4169	6	2008-	EFI	1,1	LFR6A-11	3672	LFR6AIX-11	6619	
Z300	300	3300		2004-2005		-	BKR6EKU	6993			
VZ300	300			2004-2005		-	BKR6EKU	6993			
F300TUR	300			2006-2010		1,1	LFR6A-11	3672	LFR6AIX-11	6619	
F300TXR	300			2006-2010		1,1	LFR6A-11	3672	LFR6AIX-11	6619	
LZ300A	300	3352	6	2003-2008	DFI	1,6	BKR6EKU	6993			
LF300TUR	300			2006-2010		1,1	LFR6A-11	3672	LFR6AIX-11	6619	
LF300TXR	300			2006-2010		1,1	LFR6A-11	3672	LFR6AIX-11	6619	
LZ300TUR	300			2006-2010		-	BKR6EKU	6993			
LZ300TXR	300			2006-2010		-	BKR6EKU	6993			
VZ300BTLR	300			2006-2010		-	BKR6EKU	6993			
VZ300LTR	300			2006-2010		-	BKR6EKU	6993			
Z300TUR	300			2006-2010		-	BKR6EKU	6993			
Z300TXR	300			2006-2010		-	BKR6EKU	6993			
F350A	350	5330	8	2007-	EFI	1,1	LFR6A-11	3672	LFR6AIX-11	6619	
F350TUR	350			2006-2010		1,1	LFR6A-11	3672	LFR6AIX-11	6619	
F350TXR	350			2006-2010		1,1	LFR6A-11	3672	LFR6AIX-11	6619	
FL350A	350	5330	8	2008-	EFI	1,1	LFR6A-11	3672	LFR6AIX-11	6619	
LF350TXR	350			2006-2010		1,1	LFR6A-11	3672	LFR6AIX-11	6619	
LF350TUR	350			2006-2010		1,1	LFR6A-11	3672	LFR6AIX-11	6619	
YAMATO											
35				-		0,5	B6HS	4510	BR6HIX	3419	
350				-		0,5	B6HS	4510	BR6HIX	3419	
ZÜNDAPP											
Delphin				-		0,5	B6HS	4510	BR6HIX	3419	
type 304	5			-		0,5	B6HS	4510	BR6HIX	3419	
type 304	6			-		0,5	B6HS	4510	BR6HIX	3419	

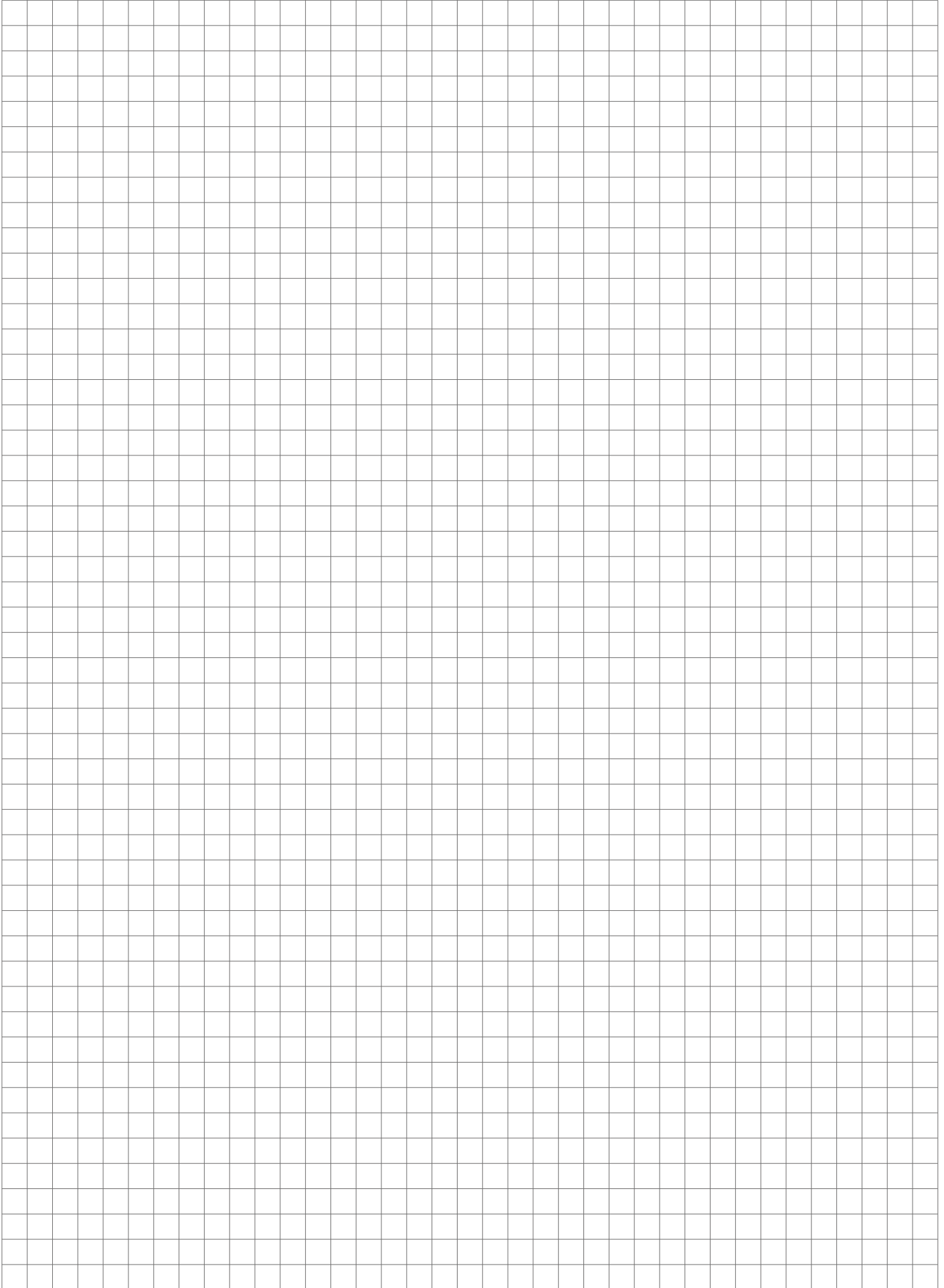



IGNITION
PARTS

C
Y
I

Stock-Nº

FRIBUM

Stock-NºX

AERO MARINE

165 CR Series	1966 - 1970		0,8	BR6ES	4922		
240 Series	-		0,6	XR5	3332	XR5IX	7355
265 Series	1969 - 1970		0,9	XR5	3332	XR5IX	7355
265 Series	1971 -		1,1	UR4	6630	UR4IX	7401
304	-		0,8	BPR6ES	7822	BPR6EIX	6637
320 Series	1966 - 1970		0,8	BR6ES	4922		
320 Series	1971 -		1,1	UR4	6630	UR4IX	7401
350 Series	1966 - 1970		0,8	BR6ES	4922		
360 Jet	-		0,8	BPR6ES	7822	BPR6EIX	6637
375 Series	1966 - 1970		0,8	BR6ES	4922		
375 Series	1970 - 1971		1,1	UR4	6630	UR4IX	7401
427 Jet Series	1971 -		1,1	UR4	6630	UR4IX	7401
454 Series	-		1,1	UR4	6630	UR4IX	7401
455 Series	-		0,9	XR5	3332	XR5IX	7355
482 Series	-		0,8	BPR6ES	7822	BPR6EIX	6637

ALBIN

0-1	-	(No.18965-->)	0,8	AB-6	2910		
0-11	-		0,8	AB-6	2910		
0-1L	-	(No.1948-->)	0,6	B6HS	4510	BR6HIX	3419
0-2	-	(No.15826-->)	0,8	AB-6	2910		
0-21	-		0,6	B6HS	4510	BR6HIX	3419
0-21	-		0,8	AB-6	2910		
0-41	-		0,8	AB-6	2910		
0-411	-		0,8	AB-6	2910		
0-4SP	-	(No. 19325-->)	0,8	AB-6	2910		
2000 SP	-		0,7	BR7HS	4122	BR7HIX	7067
2000 V-1	-		0,6	B6HS	4510	BR6HIX	3419
A4	-		0,6	B6HS	4510	BR6HIX	3419
A-6SP	-		0,7	BR7HS	4122	BR7HIX	7067
AL22, AL23	-		0,8	AB-6	2910		
E4, E5, E6	-		0,8	AB-6	2910		
G-6, G-6B	-		0,8	AB-6	2910		
S-4	-		0,6	B6HS	4510	BR6HIX	3419
T-4	-		0,8	AB-6	2910		
T1500 Special	-		0,6	B6HS	4510	BR6HIX	3419

AMECO

302 Ford Engine	-		0,8	WR5	2438	WR5IX	7510
351 W cid Ford Engine	-		0,8	WR5	2438	WR5IX	7510

AMERICAN CHALLENGER

Eagle 400	-		0,5	UR5	2771	UR5IX	7177
Eagle 600	-		0,5	UR5	2771	UR5IX	7177
Eagle 800	-		0,5	UR5	2771	UR5IX	7177

C
Y
I

Stock-Nº



Stock-NºX

AUSTIN

Healey 35, 55, 75		-		0,6	BR6ES	4922		
Healey 3300		-		0,6	BR6ES	4922		
Skipper		-		0,6	BR6ES	4922		

AVON**YAMAHA**

60 hp - 3.46 Jet R.I.B.		-		1,0	BR7HS-10	1098		
83 hp - SE 320 Jet		-		1,0	BR7HS-10	1098		
83 hp - SE 320 Jet ddl		-		1,0	BR7HS-10	1098		
83 hp - SE 420 Jet ddl		-		1,0	BR7HS-10	1098		

B & W

BW 30, 35		-		0,6	B6ES	7310		
BW 60, 105, 155, 165		-		0,6	B6S	3510		
LH Master / LH (dual ign.)		-		0,6	B6S	3510		
LH Super		-		0,6	B6S	3510		

BARR (CONVERSIONS)**BUICK**

Buick Engine 400/430 cid		1967 - 1969		1,1	UR4	6630	UR4IX	7401
Buick Engine 455 cid		1970 - 1970		0,8	BR6FS	4323		
Buick Engine 455 cid		1971 - 1974		0,7	BPR5FS	2423	UR5IX	7177

CHEVROLET

Chevrolet Engine 194/230 cid		1962 - 1969		0,9	BPR5ES	7422	BPR5EIX	6597
Chevrolet Engine 230 cid		1970 -		1,1	UR4	6630	UR4IX	7401
Chevrolet Engine 250 cid		1962 - 1969		0,9	BPR5ES	7422	BPR5EIX	6597
Chevrolet Engine 250 cid		1970 - 1978		0,7	BPR5FS	2423	UR5IX	7177
Chevrolet Engine 250 cid		1979 - 1984		1,1	UR4	6630	UR4IX	7401
Chevrolet Engine 283 cid		1955 - 1967		1,0	XR4	5858	XR4IX	7189
Chevrolet Engine 292 cid		1963 - 1969		0,9	BR6ES	4922		
Chevrolet Engine 292 cid		1970 - 1992		1,1	UR4	6630	UR4IX	7401
Chevrolet Engine 302 cid		1967 - 1969		0,9	XR4	5858	XR4IX	7189
Chevrolet Engine 307 cid		1968 - 1970		1,0	XR4	5858	XR4IX	7189
Chevrolet Engine 307 cid		1971 - 1973		0,7	BPR5FS	2423	UR5IX	7177
Chevrolet Engine 327 cid		1961 - 1969		0,9	XR5	3332	XR5IX	7355
Chevrolet Engine 350 cid		1971 - 1990		1,1	UR4	6630	UR4IX	7401
Chevrolet Engine 350 cid 2-bbl		1967 - 1970		1,0	XR4	5858	XR4IX	7189
Chevrolet Engine 350 cid 4-bbl	8	1970 -		1,0	XR4	5858	XR4IX	7189
Chevrolet Engine 400 cid		1970 -		1,0	XR4	5858	XR4IX	7189
Chevrolet Engine 400 cid		1971 - 1990		1,1	UR4	6630	UR4IX	7401
Chevrolet Engine 427 cid		1971 - 1972		0,9	UR5	2771	UR5IX	7177
Chevrolet Engine 427 cid		1973 - 1990		1,1	UR4	6630	UR4IX	7401
Chevrolet Engine 454 cid		1979 - 1989		1,1	UR4	6630	UR4IX	7401

CHRYSLER

Chrysler Engine 383 cid 2-bbl		1960 - 1971		0,9	BP-4	2911	XR4IX	7189
Chrysler Engine 383 cid 4-bbl		1968 - 1971		1,0	XR4	5858	XR4IX	7189
Chrysler Engine 383 cid Hi-Perf.		1966 - 1967		1,0	XR4	5858	XR4IX	7189
Chrysler Engine 413 cid		1963 - 1965		0,9	BP-4	2911	XR4IX	7189

C
Y
I

Stock-Nº



Stock-NºX

Chrysler Engine 413 cid Hi-Perf.	1963-1965		1,0	XR4	5858	XR4IX	7189
Chrysler Engine 413 cid two 4-bbl	1963-1964		1,0	XR4	5858	XR4IX	7189
Chrysler Engine 440 cid 350 hp	1966-1971		1,0	XR4	5858	XR4IX	7189
Chrysler Engine 440 cid 375 hp	1966-1971		0,9	XR4	5858	XR4IX	7189
Chrysler Engine 440 cid	1972-1979		1,0	XR4	5858	XR4IX	7189

OLDSMOBILE

Oldsmobile Engine 350 cid	1971-1974		1,0	XR4	5858	XR4IX	7189
Oldsmobile Engine 350 cid 2-bbl	1968-1970		1,0	XR4	5858	XR4IX	7189
Oldsmobile Engine 350 cid 4-bbl	1968-1970		1,0	XR4	5858	XR4IX	7189
Oldsmobile Engine 455 cid	1976-1978		0,9	BP-4	2911	XR4IX	7189
Oldsmobile Engine 455 cid 2-bbl	1968-1970		0,8	BP5S			
Oldsmobile Engine 455 cid 2-bbl	1971-1971		0,9	BP-4	2911	XR4IX	7189
Oldsmobile Engine 455 cid 4-bbl	1970-1971		1,0	XR4	5858	XR4IX	7189
Oldsmobile Engine 455 cid 4-bbl	1972-1974		0,9	BP-4	2911	XR4IX	7189
Oldsmobile Engine 455 cid Hi-Perf.	1972-1974		1,0	XR4	5858	XR4IX	7189

PONTIAC

Pontiac Engine 389 cid	1960-1967		1,0	XR4	5858	XR4IX	7189
Pontiac Engine 400 cid	1967-1971		1,0	XR4	5858	XR4IX	7189
Pontiac Engine 400 cid	1972-1974		0,7	BPR5FS	2423	UR5IX	7177
Pontiac Engine 421 cid	1963-1966		1,0	XR4	5858	XR4IX	7189
Pontiac Engine 428 cid	1967-1969		1,0	XR4	5858	XR4IX	7189
Pontiac Engine 455 cid	1972-1974		0,7	BPR5FS	2423	UR5IX	7177
Pontiac Engine 455 cid 2-bbl	1971-1971		0,9	BP-4	2911	XR4IX	7189
Pontiac Engine 455 cid 4-bbl	1970-1971		0,9	BP-4	2911	XR4IX	7189

BAUDOIN

CR , H4 , LH , LK , LKL	-		0,6	B-6L	3212		
LA , LO3 , LO3H , LOL	-		0,5	B-4	3210		
VL3 , VL3F , VL3FT	-		0,5	B6S	3510		

BAYLINER

Mercury Engine Sportjet 175XR2	-		1,0	BZ7HS-10	3579		
Mercury Engine Sportjet 95XR	-		1,0	BZ7HS-10	3579		
Mercury Engine Sportjet 120XR	-		1,0	BZ7HS-10	3579		

BAYSTALKER

70 hp - Twinjet 300cc	3	-	0,6	BR7HS	4122	BR7HIX	7067
-----------------------	---	---	-----	-------	------	--------	-------------

BERKELEY**CHEVROLET**

350 cid Chevrolet	1976-1990		0,9	YR5	7052	YR5IX	7516
-------------------	-----------	--	-----	-----	------	-------	-------------

FORD

302 cid Ford	1974-1990	Ø14mm	0,9	UR5	2771	UR5IX	7177
302 cid Ford	1974-1977	Ø18mm	0,9	AR6FS	3323		
351 cid Ford	1974-1990	Ø14mm	0,9	UR5	2771	UR5IX	7177
351 cid Ford	1974-1977	Ø18mm	0,9	AR6FS	3323		
460 cid Ford Big Block	1976-1990		0,9	UR5	2771	UR5IX	7177

GM

454 cid GM Big Block	1976-1990		0,9	YR5	7052	YR5IX	7516
----------------------	-----------	--	-----	-----	------	-------	-------------

C
Y
I

Stock-Nº



Stock-NºX

OLDSMOBILE

455 cid Oldsmobile	1968 - 1976		1,0	XR4	5858	XR4IX	7189
--------------------	-------------	--	-----	-----	------	-------	-------------

BLMC

850 Sea Prince 2912 cc	-		0,6	BP5ES	6511	BPR5EIX	6597
950	-		0,6	B6ES	7310		
1100 Vedette	-		0,6	B6ES	7310		
1100 Vedette	-		0,6	BR6ES			
1622 Navigator 1959	-		0,6	B6ES	7310		
1678	-		0,6	B6ES	7310		
3000 cc	-		0,6	B6ES	7310		

BMW

411	-		0,6	BP6ES	7811	BPR6EIX	6637
412	-		0,6	BP8ES	2912	BPR8EIX	6684
611	-		0,6	BP6ES	7811	BPR6EIX	6637
B130	-		0,6	BP5ES	6511	BPR5EIX	6597
B130S	-		0,6	BP5ES	6511	BPR5EIX	6597
B190	-		0,6	BP5ES	6511	BPR5EIX	6597
B1901	-		0,6	BP5ES	6511	BPR5EIX	6597
B190S	-		0,6	BP5ES	6511	BPR5EIX	6597
B220	-		0,6	BP5ES	6511	BPR5EIX	6597
B2201	-		0,6	BP5ES	6511	BPR5EIX	6597
B220S	-		0,6	BP5ES	6511	BPR5EIX	6597
G1301	-		0,6	BP5ES	6511	BPR5EIX	6597
G130S	-		0,6	BP5ES	6511	BPR5EIX	6597
G1901	-		0,6	BP5ES	6511	BPR5EIX	6597
G190S	-		0,6	BP5ES	6511	BPR5EIX	6597
G2201	-		0,6	BP5ES	6511	BPR5EIX	6597
G220S	-		0,6	BP5ES	6511	BPR5EIX	6597

BLADE

70 hp - 400cc	-		0,6	BR7HS	4122	BR7HIX	7067
115 hp - 440cc	-		0,8	BZ7HS-10	3579		

BLUE-FIN

Mercury Engine Sportjet 90 - 550cc	-		0,8	BZ7HS-10	3579		
------------------------------------	---	--	-----	----------	------	--	--

BOMBARDIER (Sea-Doo)

Challenger Rotax - 787 cc	-		0,6	BR8ES	5422	BR8EIX	5044
Explorer Rotax - 717cc	-		0,6	BR8ES	5422	BR8EIX	5044
Speedster Rotax - 717cc	-		0,5	BR8ES	5422	BR8EIX	5044
Sportser Rotax - 717cc	-		0,6	BR8ES	5422	BR8EIX	5044
Sportster LE DI - 947cc	-		1,1	ZFR4F-11	4043		
150 Speedster - 1494cc	2007 - 2009		0,7	DCPR8E	4339	DCPR8EIX	6546
180 Challenger CS - 1494cc	2005 - 2009		0,7	DCPR8E	4339	DCPR8EIX	6546
200 Speedster / Twin 4-Tec - 1494cc	2006 - 2009		0,7	DCPR8E	4339	DCPR8EIX	6546
205 Utopia - 1494cc	2008 - 2009		0,7	DCPR8E	4339	DCPR8EIX	6546

C
Y
I

Stock-Nº



Stock-NºX

210 Challenger - 1494cc	2010-2011		0,7	DCPR8E	4339	DCPR8EIX	6546
210 SP - 1494cc	2011 -		0,7	DCPR8E	4339	DCPR8EIX	6546
210 Wake - 1494cc	2010-2011		0,7	DCPR8E	4339	DCPR8EIX	6546
230 Challenger - 1494cc	2007-2009		0,7	DCPR8E	4339	DCPR8EIX	6546
230 Wake - 1494cc	2008-2009		0,7	DCPR8E	4339	DCPR8EIX	6546
Challenger 180 - 1494cc	2006-2007		0,7	DCPR8E	4339	DCPR8EIX	6546
Challenger CS - 1494cc	2006-2006		0,7	DCPR8E	4339	DCPR8EIX	6546
Islandia 220 - 1494cc	2006-2007		0,7	DCPR8E	4339	DCPR8EIX	6546
Islandia SE - 1494cc	2008-2009		0,7	DCPR8E	4339	DCPR8EIX	6546
Speedster Wake - 1494cc	2007-2009		0,7	DCPR8E	4339	DCPR8EIX	6546
Sportster 4-Tec - 1494cc	2006 -		0,7	DCPR8E	4339	DCPR8EIX	6546
Sportster LE DI - 1494cc	2006 -		0,9	ZFR4F-11	4043		
Utopia 205 - 1494cc	2006-2007		0,7	DCPR8E	4339	DCPR8EIX	6546
Challenger 180 4-Tec - 1498cc	2005-2005		0,7	DCPR8E	4339	DCPR8EIX	6546

BOSTON WHALER

OMC Turbojet 115 - 650cc	-		0,8	BZ7HS-10	3579		
Redline 302 cid - 744cc	-		1,0	BPR5FS	2423	UR5IX	7177
Redline 351 cid HO - 750cc	-		1,0	BPR5EFS	2223	TR5IX	7397

BRIT. SEAGULL

ST110 1494cc	1979-1981		0,9	AB-6	2910		
--------------	-----------	--	-----	------	------	--	--

BUCCANEER

MERCURY

Mercury Sportjet 90 - 750cc	-		1,0	BZ7HS-10	3579		
Mercury Sportjet 120XR - 782cc	-		1,0	BZ7HS-10	3579		

OMC

OMC Turbojet 115 - 891cc	-		1,0	BZ7HS-10	3579		
--------------------------	---	--	-----	----------	------	--	--

CARIBE

Mercury Sportjet 90 - 899cc	-		1,0	BZ7HS-10	3579		
Mercury Sportjet 120XR - 900cc	-		1,0	BZ7HS-10	3579		

CASTOLDI

113hp - 1966 cc	1974 -		0,9	APR6FS	2922		
2261E - 639cc	1974 -		0,9	BR6ES	4922		
2264E - 644cc	1974 -		0,9	BPR5ES	7422	BPR5EIX	6597
2614E - 768cc	1974 -		0,6	BPR6ES	7822	BPR6EIX	6637

CHECKMATE

Mercury Sportjet 90 - 900cc	-		1,0	BZ7HS-10	3579		
Mercury Sportjet 120XR - 900cc	-		1,0	BZ7HS-10	3579		
Mercury Sportjet 175XR2 - 1071cc	-		1,0	BZ7HS-10	3579		

C
Y
I

Stock-Nº



Stock-NºX

CHEVROLET (MARINE CONVERSIONS)

194 cid	6	1962-1969		0,9	BPR5ES	7422	BPR5EIX	6597
230 cid	6	1962-1969		0,8	BPR5ES	7422	BPR5EIX	6597
230 cid	6	1970-		1,1	UR4	6630	UR4IX	7401
250 cid	6	1962-1969		0,9	BPR5ES	7422	BPR5EIX	6597
250 cid	6	1970-1978		0,9	BPR5FS			
250 cid	6	1979-1984		1,1	UR4	6630	UR4IX	7401
283 cid	8	1955-1967		1,0	XR4	5858	XR4IX	7189
292 cid	6	1963-1969		1,1	UR4	6630	UR4IX	7401
292 cid	6	1970-1978		0,7	BPR5FS	2423	UR5IX	7177
302 cid	8	1967-1969		0,9	XR4	5858	XR4IX	7189
307 cid	8	1968-1970		0,9	XR4	5858	XR4IX	7189
307 cid	8	1971-1973		0,7	BPR5FS	2423	UR5IX	7177
327 cid	8	1961-1969		0,9	XR5	3332	XR5IX	7355
350 cid	8	1971-1990		1,1	UR4	6630	UR4IX	7401
350 cid 2-bbl	8	1967-1970		1,0	XR4	5858	XR4IX	7189
350 cid 4-bbl	8	1970-		1,0	XR4	5858	XR4IX	7189
400 cid	8	1970-		1,0	XR4	5858	XR4IX	7189
400 cid	8	1971-1990		1,1	UR4	6630	UR4IX	7401
427 cid	8	1971-1972		0,7	UR6	7773	UR6IX	7348
427 cid	8	1973-1990		1,1	UR4	6630	UR4IX	7401
454 cid	8	1979-1990		0,8	UR5	2771	UR5IX	7177
454 cid	8	1979-1990		0,9	BR6FS			

CHRIS-CRAFT

153		-		0,9	BR6ES	4922		
181 (-->603191)		-		0,9	BR6ES	4922		
181 (603192-->)		-		0,9	BPR6FS	2623	UR6IX	7348
225		-		0,9	BP6S	3111		
283 (Flat Cylinder Head)		-		0,6	B6S	3510		
302 (Flat Cylinder Head)		-		0,6	B6S	3510		
307 (Flat Cylinder Head)		-		0,6	B6S	3510		
307 (Tapered seat)		-		0,6	BPR6FS	2623	UR6IX	7348
327 (Flat Cylinder Head)		-		0,6	B6S	3510		
350 Hi-Perf.		-		0,9	BR6FS	4323	BR6FIX	2318
350 (Tapered seat)		-		0,6	BPR6FS	2623	UR6IX	7348
427 Series		-		0,8	A6FS	2210		
430 Series		-		0,8	AP6FS	2710		
431 Series		-		0,8	A6FS	2210		
454 (Tapered seat)		-		0,6	BPR6FS	2623	UR6IX	7348
A (Alu. Cylinder Head)		-		0,7	B-6L			
A (Cast Iron Cylinder Head)		-		0,7	B6S			
B (Alu. Cylinder Head)		-		0,7	B-6L			
B (Cast Iron Cylinder Head)		-		0,7	B6S			
BA (Alu. Cylinder Head)		-		0,7	B-6L			
BA (Cast Iron Cylinder Head)		-		0,7	B6S			
C (Alu. Cylinder Head)		-		0,7	B-6L			
C (Cast Iron Cylinder Head)		-		0,7	B6S			
H (Alu. Cylinder Head)		-		0,7	B-6L			
H (Cast Iron Cylinder Head)		-		0,7	B6S			
K (Alu. Cylinder Head)		-		0,7	B-6L			



C
Y
L



Stock-Nº







FRIBUM

Stock-NºX

K (Cast Iron Cylinder Head)		-		0,7	B6S			
KB (Alu. Cylinder Head)		-		0,7	B-6L			
KB (Cast Iron Cylinder Head)		-		0,7	B6S			
KBL (Alu. Cylinder Head)		-		0,7	B-6L			
KBL (Cast Iron Cylinder Head)		-		0,7	B6S			
KC (Alu. Cylinder Head)		-		0,7	B-6L			
KC (Cast Iron Cylinder Head)		-		0,7	B6S			
KFL (Alu. Cylinder Head)		-		0,7	B-6L			
KFL (Cast Iron Cylinder Head)		-		0,7	B6S			
KL (Alu. Cylinder Head)		-		0,7	B-6L			
KL (Cast Iron Cylinder Head)		-		0,7	B6S			
KLC (Alu. Cylinder Head)		-		0,7	B-6L			
KLC (Cast Iron Cylinder Head)		-		0,7	B6S			
LC (Alu. Cylinder Head)		-		0,7	B-6L			
LC (Cast Iron Cylinder Head)		-		0,7	B6S			
LD (Alu. Cylinder Head)		-		0,7	B-6L			
LD (Cast Iron Cylinder Head)		-		0,7	B6S			
M (Alu. Cylinder Head)		-		0,7	B-6L			
M (Cast Iron Cylinder Head)		-		0,7	B6S			
MB (Alu. Cylinder Head)		-		0,7	B-6L			
MB (Cast Iron Cylinder Head)		-		0,7	B6S			
MBL (Alu. Cylinder Head)		-		0,7	B-6L			
MBL (Cast Iron Cylinder Head)		-		0,7	B6S			
MC (Alu. Cylinder Head)		-		0,7	B-6L			
MC (Cast Iron Cylinder Head)		-		0,7	B6S			
MCL (Alu. Cylinder Head)		-		0,7	B-6L			
MCL (Cast Iron Cylinder Head)		-		0,7	B6S			
ML (Alu. Cylinder Head)		-		0,7	B-6L			
ML (Cast Iron Cylinder Head)		-		0,7	B6S			
W (Alu. Cylinder Head)		-		0,7	B-6L			
W (Cast Iron Cylinder Head)		-		0,7	B6S			
WB (Alu. Cylinder Head)		-		0,7	B-6L			
WB (Cast Iron Cylinder Head)		-		0,7	B6S			

CHRYSLER

M91D/F	4	-		0,9	BP6ES	7811	BPR6EIX	6637
M122A/B	4	-		0,9	B7HS	5110	BR7HIX	7067
B46-4	6	-		0,9	BR6S	3522		
B46S-3	6	-		0,9	BR6S	3522		
M46-3/4	6	-		0,9	BR6S	3522		
M46S-3	6	-		0,9	BR6S	3522		
M47-3/4	6	-		0,9	BR6S	3522		
M47S-3	6	-		0,9	BR6S	3522		
M170	6	-		0,9	BR6ES	4922		
M183B	6	-		0,9	B7HS	5110	BR7HIX	7067
M225A	6	-		0,9	BR6ES	4922		
M225D	6	-		0,9	BR6ES	4922		
M225D	6	-1975		0,9	BR6ES	4922		
M225D	6	1976-1979		0,9	BPR6FS	2623	UR6IX	7348
M225GD	6	-		0,9	BR6ES	4922		
M265	6	-		0,9	BR6S	3522		
M265A	6	-		0,9	BR6S	3522		

	C Y I					Stock-Nº		Stock-NºX
MH225D	6	-		0,9	BR6ES	4922		
LM318A	8	-		0,9	BPR6ES	7822	BPR6EIX	6637
LM318AC	8	-		0,9	BPR6ES	7822	BPR6EIX	6637
LM318B	8	-		0,9	BPR6ES	7822	BPR6EIX	6637
LM318BC	8	-		0,9	BPR6ES	7822	BPR6EIX	6637
LM318BJ	8	-		0,9	BPR6ES	7822	BPR6EIX	6637
LM318BT	8	-		0,9	BPR6ES	7822	BPR6EIX	6637
LM318BV	8	-		0,9	BPR6ES	7822	BPR6EIX	6637
LM318D	8	-		0,9	BPR6ES	7822	BPR6EIX	6637
LM340B	8	-		0,9	BPR6ES	7822	BPR6EIX	6637
LM340BJ	8	-		0,9	BPR6ES	7822	BPR6EIX	6637
LM340BT	8	-		0,9	BPR6ES	7822	BPR6EIX	6637
LM340BV	8	-		0,9	BPR6ES	7822	BPR6EIX	6637
M44	8	-		0,9	BR6S	3522		
M44-3	8	-		0,9	BR6S	3522		
M45	8	-		0,9	BR6ES	4922		
M45-3	8	-		0,9	BR6ES	4922		
M45S	8	-		0,9	BR6ES	4922		
M45-S3	8	-		0,9	BR6ES	4922		
M45-SP3	8	-		0,9	BR6ES	4922		
M80	8	-		0,9	XR5	3332	XR5IX	7355
M81	8	-		0,9	BR6ES	4922		
M273A	8	-		0,9	BPR6ES	7822	BPR6EIX	6637
M273B	8	-		0,9	BPR6ES	7822	BPR6EIX	6637
M273BT	8	-		0,9	BPR6ES	7822	BPR6EIX	6637
M318A	8	-		0,9	XR5	3332	XR5IX	7355
M318B	8	-		0,9	XR5	3332	XR5IX	7355
M318C	8	-		0,9	XR5	3332	XR5IX	7355
M318GD	8	-		0,9	XR5	3332	XR5IX	7355
M360A	8	-		0,9	BPR6ES	7822	BPR6EIX	6637
M360B	8	-		0,9	BPR6ES	7822	BPR6EIX	6637
M360BC	8	-		0,9	BPR6ES	7822	BPR6EIX	6637
M360BJ	8	-		0,9	BPR6ES	7822	BPR6EIX	6637
M360BT	8	-		0,9	BPR6ES	7822	BPR6EIX	6637
M360BV	8	-		0,9	BPR6ES	7822	BPR6EIX	6637
M383B	8	-		0,9	XR5	3332	XR5IX	7355
M383BV	8	-		0,9	XR5	3332	XR5IX	7355
M400B	8	-		0,9	XR5	3332	XR5IX	7355
M400BV	8	-		0,9	XR5	3332	XR5IX	7355
M400S	8	-		0,9	XR5	3332	XR5IX	7355
M413B	8	-		0,9	XR5	3332	XR5IX	7355
M413D	8	-		0,9	XR5	3332	XR5IX	7355
M413E	8	-		0,9	BR6ES	4922		
M426B	8	-		0,9	XR5	3332	XR5IX	7355
M426D	8	-		0,9	XR5	3332	XR5IX	7355
M426-Ski	8	-		0,9	XR5	3332	XR5IX	7355
M440B	8	-		0,9	XR5	3332	XR5IX	7355
M440BJ	8	-		0,9	XR5	3332	XR5IX	7355
M440BV	8	-		0,9	XR5	3332	XR5IX	7355
M440D	8	-		0,9	XR5	3332	XR5IX	7355
M440S	8	-		0,9	XR5	3332	XR5IX	7355
M440SV	8	-		0,9	XR5	3332	XR5IX	7355
M460B	8	-		0,9	UR5	2771	UR5IX	7177

C
Y
I

Stock-N°



Stock-N°

CHRYSLER-VOLVO

110	-	0,7	BR7HS	4122	BR7HIX	7067
115	-	0,7	BR7HS	4122	BR7HIX	7067
120	-	0,7	BR7HS	4122	BR7HIX	7067
130	-	0,7	BR7HS	4122	BR7HIX	7067
165	-	0,7	BR7HS	4122	BR7HIX	7067
170	-	0,7	BR7HS	4122	BR7HIX	7067

CLAE

Bantam 3 hp	-	0,8	AB-6	2910		
Bantam 4 hp	-	0,8	AB-6	2910		
C35	-	0,8	B6S	3510		
C35A	-	0,8	B6S	3510		
Fisherman Six 5 hp	-	0,8	AB-6	2910		
Fisherman Six 6 hp	-	0,8	AB-6	2910		
Fisherman Ten 10 hp	-	0,8	AB-6	2910		
Fisherman Ten 12 hp	-	0,8	AB-6	2910		
Falcon Conversion	-	0,8	AP5FS	2610	WR5IX	7510
Holden 25 - Culot court	-	0,8	BP5S	3011	XR5IX	7355
Holden 50 - Culot court	-	0,8	BP5S	3011	XR5IX	7355
Holden Conversion - Culot long	-	0,6	BP5ES	6511	BPR5EIX	6597
Valiant Conversion	-	0,8	B6ES	7310		

CLASSIC JET CRAFT

Mercury Sportjet 90 - 1100cc	-	1,0	BZ7HS-10	3579		
------------------------------	---	-----	----------	------	--	--

CLIMAX







98 cid	-	0,8	BPR6ES	7822	BPR6EIX	6637
302 cid	-	0,8	A6FS	2210		
351 cid	-	0,8	A6FS	2210		
460 cid	-	0,8	APR6FS	2922		

CON-O-LIFT

2.3 hp - Ford 300 cid	-	0,8	AR6FS	3323		
2.5 hp - Wisconsin.	-	0,6	AB-6	2910		
2.0 hp - Chrysler 225 cid	-	0,9	BPR5FS	2423	UR5IX	7177

CRUSADER

200 cid	1979 - 1979	0,9	BPR6FS	2623	UR6IX	7348
229 cid - 165	1979 - 1980	0,9	BPR6FS	2623	UR6IX	7348
229 cid - CH185	1981 - 1984	0,9	BPR6FS	2623	UR6IX	7348
262 cid	1985 - 1998	0,9	BPR6FS	2623	UR6IX	7348
292 cid - 185	1971 - 1980	0,9	R5674-7	3535		
302 cid	1974 - 1975	0,8	AR6FS	3323		
305 cid - 190	1976 - 1996	0,9	BPR6FS	2623	UR6IX	7348
305 cid - 220	1976 - 1996	0,9	BPR6FS	2623	UR6IX	7348
307 cid - 210	1971 - 1980	0,9	R5674-7	3535		

	C Y I					Stock-Nº		Stock-NºX
350 cid - 270		1971 - 1998		0,9	BPR6FS	2623	UR6IX	7348
351 cid - 255		1974 - 1975		0,8	AR6FS	3323		
427 cid - 427		1968 - 1980		0,9	R5674-7	3535		
454 cid - 350		1972 - 1980		0,9	BPR6FS	2623	UR6IX	7348
454 cid - 454		1981 - 1998		0,9	BPR6FS	2623	UR6IX	7348
460 cid - 350		1974 - 1975		0,9	BPR6FS	2623	UR6IX	7348
502 cid		1989 - 1998		0,9	BPR6FS	2623	UR6IX	7348
BOAT BUILDER								
170J		-		0,6	B6S	3510		
185/190		-		0,6	B6S	3510		
200J		-		0,6	B6S	3510		
210/220		-		0,6	B6S	3510		
230/230J		-		0,6	B6S	3510		
250		-		0,6	B6S	3510		
280 - 9.9 hp		-		0,9	BR6ES	4922		
CS100		-		0,8	B6ES	7310		
CS150		-		0,8	B6ES	7310		
CS165		-		0,8	B6ES	7310		
CS180		-		0,8	B6S	3510		
CS220		-		0,8	B6S	3510		
CS250		-		0,8	B6S	3510		
CS280		-		0,8	B6ES	7310		
CS320		-		0,8	B6ES	7310		
Mark 140/170/200/225		-		0,6	B6S			
Mark 240		-		0,8	B6ES			
Mark 275/300/325		-		0,8	B7S			
CHAMPION								
305 cid		-		0,9	BPR6FS	2623	UR6IX	7348
350 cid		-		0,9	BPR6FS	2623	UR6IX	7348
350 cid HT		-		0,9	BPR6FS	2623	UR6IX	7348
454 cid		-		0,9	BPR6FS	2623	UR6IX	7348
CHARGER								
CS185/220/250		-		0,6	B6S	3510		
CS280		-		0,9	B6ES	7310		
CS320		-		0,8	B6ES	7310		
CLASSIC								
5.7L Plus EFI		-		1,1	TR5	2238	TR5IX	7397
5.7L Plus MPI		-		1,1	TR5	2238	TR5IX	7397
7.4L HO MPI		-		1,1	BR6FS	4323	BR6FIX	2318
7.4L MPI		-		1,1	TR5	2238	TR5IX	7397
8.2L MPI		-		1,1	BR6FS	4323	BR6FIX	2318
GM								
220 hp GM V8 5.7L MP	8	2005-		1,5	TR55	3951	TR55IX	7164
275 hp GM V8 5.0L MP	8	2005-		1,5	TR55	3951	TR55IX	7164
300 hp GM V8 5.7L CARB	8	-		1,5	TR55	3951	TR55IX	7164
375 hp GM V8 6.0L MP	8	-		1,5	TR55	3951	TR55IX	7164
385 hp GM V8 8.1L MP	8	-		1,5	TR55	3951	TR55IX	7164
425 hp GM V8 8.1L MP (HO)	8	-		1,5	TR55	3951	TR55IX	7164
MARK								
Mark 140/170/185/200/210/225/230		-		0,6	B6S	3510		
Mark 170J/200J/230J		-		0,6	B6S	3510		
Mark 240		-		0,8	B6ES	7310		
Mark 275		-		0,8	B8S	3810		

C
Y
I

Stock-Nº



Stock-NºX

Mark 280	-	0,8	B6ES	7310		
Mark 300/325	-	0,8	B8S	3810		

PLATINUM

5.7L Plus MPI	-	1,1	TR5	2238	TR5IX	7397
7.4L HO MPI	-	1,1	BR6FS	4323	BR6FIX	2318
7.4L MPI	-	1,1	TR5	2238	TR5IX	7397
8.2L MPI	-	1,1	BR6FS	4323	BR6FIX	2318

XL/XLI

262 cid	-	0,9	BPR6FS	2623	UR6IX	7348
305 cid	-	0,9	BPR6FS	2623	UR6IX	7348
350 cid	-	0,9	BPR6FS	2623	UR6IX	7348
454 cid	-	0,9	BPR6FS	2623	UR6IX	7348
454 cid HO	-	0,9	BPR6FS	2623	UR6IX	7348
502 cid	-	0,9	BPR6FS	2623	UR6IX	7348

CUTTER

Mercury Sportjet 95 - 1100cc	-	1,0	BZ7HS-10	3579		
Mercury Sportjet 120XR - 1100cc	-	1,0	BZ7HS-10	3579		
Mercury Sportjet 175XR2 - 1100cc	-	1,0	BZ7HS-10	3579		

CUYUNA

430LC 40 hp Jet Drive	-	0,8	BR8ES	5422	BR8EIX	5044
-----------------------	---	-----	-------	------	--------	-------------

DAIMLER

SP 250	-	0,7	BR6ES	4922		
--------	---	-----	-------	------	--	--

DAYTONA

100	-	0,9	B6ES	7310		
150	-	0,9	B6ES	7310		
200	-	0,9	B6S	3510		
300	-	0,9	B6S	3510		
400	-	0,9	B7ES	1111	BR7EIX	6664
400 Turbo	-	0,9	B7ES	1111	BR7EIX	6664
427 / 427 Turbo heavy Service	-	0,9	B8ES	2411	BR8EIX	5044
427 / 427 Turbo light Service	-	0,9	B7ES	1111	BR7EIX	6664

DELTA JET



Mercury Sportjet 120XR - 1100cc	-	1,0	BZ7HS-10	3579		
Mercury Sportjet 175XR2 - 1176cc	-	1,0	BZ7HS-10	3579		

DIESEL-TECHNIEK

DTR 40	-	0,6	BP6HS	4511	BPR6HIX	4085
DTR 50	-	0,6	BP6HS	4511	BPR6HIX	4085

DONZI

Mercury Sportjet 90 - 1176cc	-	1,0	BZ7HS-10	3579		
------------------------------	---	-----	----------	------	--	--

	C Y I					Stock-Nº		Stock-NºX
Mercury Sportjet 120XR - 1176cc		-		1,0	BZ7HS-10	3579		
DORAL TOP								
Mercury Sportjet 95XR - 1199cc		-		1,0	BZ7HS-10	3579		
Mercury Sportjet 120XR - 1500cc		-		1,0	BZ7HS-10	3579		
DYNAFOIL								
G440-BW (432cc) Xenoah Engine		-		0,9	BR6ES	4922		
DYNASTY								
Mercury Sportjet 175XR2		-		1,0	BZ7HS-10	3579		
Mercury Sportjet 120XR		-		1,0	BZ7HS-10	3579		
Mercury Sportjet 175XR2 - 650cc		-		1,0	BZ7HS-10	3579		
Mercury Sportjet 90 - 700cc		-		1,0	BZ7HS-10	3579		
Mercury Sportjet 120XR - 700cc		-		1,0	BZ7HS-10	3579		
Mercury Sportjet 175XR2 - 700cc		-		1,0	BZ7HS-10	3579		
Mercury Sportjet 120XR - 700cc		-		1,0	BZ7HS-10	3579		
Mercury Sportjet 175XR2 - 700cc		-		1,0	BZ7HS-10	3579		
E-1 SPLASH								
70 hp - Tohatsu 750cc		-		1,0	BR7HS-10	1098		
EKLER WATERSPORTS								
Yamaha Engine 650cc		-		1,0	BR7HS-10	1098		
Yamaha Engine 700cc		-		1,0	BR7HS-10	1098		
ELIMINATOR								
Chevy 454 cid - 777cc		-		1,0	BPR5FS	2423	UR5IX	7177
EMERALD BAY								
50 hp - 777cc		-		1,0	BR9ES	5722	BR9EIX	3981
80 hp - 779cc		-		1,0	BR9ES	5722	BR9EIX	3981
EPIC PERFORMANCE								
Mercury Sportjet 90 - 780cc		-		1,0	BZ7HS-10	3579		
Mercury Sportjet 120XR - 900cc		-		1,0	BZ7HS-10	3579		
EUROLINE								
INDMAR								
270 hp - Indmar 350 cid - 1050cc		-		1,1	BR5FS	4123		
MERCURY								
Mercury Sportjet 90 - 1165cc		-		1,0	BZ7HS-10	3579		
Mercury Sportjet 95 - 1165cc		-		1,0	BZ7HS-10	3579		
Mercury Sportjet 120XR - 1165cc		-		1,0	BZ7HS-10	3579		

C
Y
I

Stock-Nº

FRIDUM

Stock-NºX

Mercury Sportjet 175XR2 - 1165cc	-		1,0	BZ7HS-10	3579		
Mercury Sportjet 95 - 1165cc	-		1,0	BZ7HS-10	3579		
Mercury Sportjet 120XR - 1165cc	-		1,0	BZ7HS-10	3579		
Mercury Sportjet 175XR2 - 1192cc	-		1,0	BZ7HS-10	3579		
8.0 hp - Mercury Sportjet 175XR2	-		1,0	BZ7HS-10	3579		

OMC

7.5 hp - OMC Turbojet 115	-		0,8	BZ7HS-10	3579		
---------------------------	---	--	-----	----------	------	--	--

EVINRUDE

CU / SU 153 cid 110 / 120 hp	-		0,9	BR6ES	4922		
DU 89 cid 88 hp	-		0,8	B6S	3510		
DU 89 cid 90 hp	-		0,8	B6S	3510		
HU 225 cid 150 hp	-		0,9	BP5S	3011	XR5IX	7355
HU 225 cid 155 hp	-		0,9	BP5S	3011	XR5IX	7355
KU 283 cid 185 hp	-		0,9	B6S	3510		
NU 1600cc 89 hp	-		0,6	BP6ES	7811	BPR6EIX	6637
NU 1600cc 90 hp	-		0,6	BP6ES	7811	BPR6EIX	6637
TU 14/15/16 300 cid 200 hp	-		0,9	XR4	5858	XR4IX	7189
TU 17 ->283, 307 cid 210 hp	-		0,9	XR4	5858	XR4IX	7189

EXOTIC MARINE

9.0 hp - Mercury Sportjet 120XR	-		1,0	BZ7HS-10	3579		
---------------------------------	---	--	-----	----------	------	--	--

FAGEOL

44	-		0,6	B6S	3510		
53	-		0,6	B6S	3510		
FM 200	-		0,5	B6S	3510		
FM 225	-		0,5	B6S	3510		

FLAGSHIP

181 cid - 181FL	1975 - 1977		0,9	YR5	7052	YR5IX	7516
280 cid - 280E	1975 - 1977		0,9	R5674-7	3535		
292 cid	1971 - 1974		0,9	UR5	2771	UR5IX	7177
292 cid - 155	-		0,9	B6ES	7310		
300 cid - Heavy Service	1977 -		1,1	R5674-7	3535		
300 cid - Light Service	1977 -		1,1	UR5	2771	UR5IX	7177
305 cid	1971 - 1974		0,9	UR5	2771	UR5IX	7177
305 cid - Heavy Service	1975 - 1993		1,1	R5674-7	3535		
305 cid - Light Service	1975 - 1977		1,1	UR5	2771	UR5IX	7177
307 cid	1971 - 1974		0,9	UR5	2771	UR5IX	7177
350 cid	1971 - 1974		0,9	UR5	2771	UR5IX	7177
295FAS (350 CID HI PERFORMANCE)	1975 - 1993		0,9	R5674-7	3535		
335 (350 CID HI PERFORMANCE)	1975 - 1993		0,9	R5674-7	3535		
350 cid - Heavy Service (350 CID HI PERFORMANCE)	1975 - 1993		1,1	R5674-7	3535		
380FAS (350 CID HI PERFORMANCE)	1975 - 1993		0,9	R5674-7	3535		
TC400 (350 CID HI PERFORMANCE)	1975 - 1993		0,9	R5674-7	3535		
TC450 (350 CID HI PERFORMANCE)	1975 - 1993		0,9	R5673-7	4367		
TC500 (350 CID HI PERFORMANCE)	1975 - 1993		0,9	R5673-8	4140		
300 (427 CID)	1971 - 1974		0,9	B7ES	1111	BR7EIX	6664



C
Y
I



Stock-Nº

FRIBUM

Stock-NºX

454 CID		1971 - 1974		0,9	UR5	2771	UR5IX	7177
Heavy Service (454 CID)		1975 - 1993		1,1	R5674-7	3535		
Light Service (454 CID)		1975 - 1977		1,1	UR5	2771	UR5IX	7177
400FAJ/FAS (454 CID HI PERFORMANCE)		1975 - 1977		0,9	R5674-7	3535		
450FAJ/FAS (454 CID HI PERFORMANCE)		1975 - 1993		0,9	R5674-7	3535		
460FAJ/FAS (454 CID HI PERFORMANCE)		1975 - 1977		0,9	R5674-7	3535		
500FAJ/FAS (454 CID HI PERFORMANCE)		1975 - 1977		0,9	R5674-7	3535		
TC500/550 (454 CID HI PERFORMANCE)		1975 - 1993		0,9	R5673-8	4140		
TC600 (454 CID HI PERFORMANCE)		1975 - 1993		0,9	R5673-7	4367		
TC650 (454 CID HI PERFORMANCE)		1975 - 1977		0,9	R5673-8	4140		
TC800 (460 CID HI PERFORMANCE)		1975 - 1977		0,9	R5673-10	2482		
675FAJ (Utilisation normale) (466 CID HI PERFORMANCE)		1975 - 1981		0,9	R5674-7	3535		
675FAJ (Racing) (466 CID HI PERFORMANCE)		1975 - 1977		0,9	R5673-10	2482		
675FAS (Utilisation normale) (466 CID HI PERFORMANCE)		1975 - 1981		0,9	R5674-7	3535		
675FAS (Racing) (466 CID HI PERFORMANCE)		1975 - 1977		0,9	R5673-10	2482		
TC700 (466 CID HI PERFORMANCE)		1975 - 1981		0,9	R5673-10	2482		
TCX950 (466 CID HI PERFORMANCE)		1975 - 1981		0,9	R5673-10	2482		
500FAJ (490 CID HI PERFORMANCE)		1975 - 1981		0,9	R5674-7	3535		
500FAS (490 CID HI PERFORMANCE)		1975 - 1981		0,9	R5674-7	3535		

FORD

Ø18mm - Flat Cylinder Head		-		0,8	AB-6	2910		
67 cid		-		0,9	GR5	2851	GR5IX	7214
98 cid		-		0,9	GR5	2851	GR5IX	7214
104 cid		-		0,7	GR4	2635	GR4IX	7149
105-E Anglia OHV		-		0,8	B5ES	6410		
109-E Anglia OHV		-		0,8	B5ES	6410		
112E		-		0,8	B5ES	6410		
115E		-		0,8	B5ES	6410		
125E		-		0,8	B5ES	6410		
144 cid - Falcon conversion	6	-		0,9	AP5FS	2610	WR5IX	7510
158 cid		-		0,9	BR6ES	4922		
172 cid		-		0,7	B-6L	3212		
201 cid		-		0,9	BR6ES	4922		
221 cid - Falcon conversion	6	-		0,9	AP5FS			
250 cid		-		0,8	AR6FS	3323		
272 cid OHV	8	-		0,8	AP6FS	2710		
292 cid OHV	8	-		0,8	AP6FS	2710		
302 cid		1975 - 1989		0,9	BPR5FS			
312 cid	8	-		0,8	AP6FS	2710		
351 cid		1975 - 1989		0,9	BPR5FS			
427 cid		1975 - 1989		0,7	UR5	2771	UR5IX	7177
427 cid 302 / 351W		- 1974		0,9	WR5	2438	WR5IX	7510
429 cid		1975 - 1989		0,7	UR5	2771	UR5IX	7177
460 cid		1975 - 1989		0,9	BPR5FS			
460 cid 302 / 351W		1975 - 1989		0,8	UR5	2771	UR5IX	7177
477 cid		- 1981		0,8	AR6FS	3323		
534 cid		1976 -		0,8	AR6FS	3323		
3004E		-		0,8	B5ES	6410		
Consul		-		0,8	BP5ES	6511	BPR5EIX	6597
Side Valve Engine (lateral)	4	-		0,8	B6HS	4510	BR6HIX	3419
V8 - (Mercury, Customs)		-		0,8	B-6L	3212		

C
Y
I

Stock-Nº



Stock-NºX

Zephyr		-		0,8	BP5ES	6511	BPR5EIX	6597
--------	--	---	--	-----	-------	------	---------	-------------

FORESTER

Mercury Sportjet 90 - 580cc		-		1,0	BZ7HS-10	3579		
-----------------------------	--	---	--	-----	----------	------	--	--

FOSTER

Honda Engine OHV 4.0 hp		-		0,8	BPR5ES	7422	BPR5EIX	6597
-------------------------	--	---	--	-----	--------	------	---------	-------------

FOUR WINNS

OMC Turbojet 90 - 650cc		-		1,0	BZ7HS-10	3579		
OMC Turbojet 115 - 650cc		-		1,0	BZ7HS-10	3579		

FUN JET

70 hp - 718cc	3	-		1,0	BR7HS-10	1098		
---------------	---	---	--	-----	----------	------	--	--

GOFF

GMP 225		1969 - 1973		0,9	XR4	5858	XR4IX	7189
GMP 455		1961 -		0,8	XR4	5858	XR4IX	7189
GMP 455		1971 - 1972		1,0	XR4	5858	XR4IX	7189
GMP 455		1973 -		1,0	XR4	5858	XR4IX	7189

GOTA

5-6 , 10-12 , 15-18		-		0,5	AB-6	2910		
SLF10 , SL3 , SL6 , SL12		-		0,5	AB-6	2910		

GRAYMARINE

EXPRESS

Four 52		-		0,7	AB-6	2910		
Four 112		-		0,7	AB-6	2910		
Four 140		-		0,7	AB-6	2910		
Four 162		-		0,7	AB-6	2910		
Seascout 91		-		0,9	BR6S	3522		
Six 71/77/80		-		0,7	AB-6	2910		
Six 91		-		0,7	AB-8	7909		
Six 111/121/186		-		0,7	AB-6	2910		
Six 224		-		0,7	AB-8	7909		
Six 427		-		0,7	AB-6	2910		
Super 117		-		0,7	AB-6	2910		
Super 427		-		0,7	AB-6	2910		

FIREBALL

135/138		-		0,7	XR5	3332	XR5IX	7355
138A		-		0,7	XR5	3332	XR5IX	7355
170/175/178		-		0,7	XR5	3332	XR5IX	7355
178B		-		0,7	XR5	3332	XR5IX	7355
188/195/215/220/225/238/260/280		-		0,7	XR5	3332	XR5IX	7355
304		-		0,7	GR4	2635	GR4IX	7149

C
Y
I

Stock-Nº

FRIDUM

Stock-NºX

310	-	0,7	XR5	3332	XR5IX	7355
360	-	0,7	GR4	2635	GR4IX	7149
427	-	0,7	XR5	3332	XR5IX	7355
C, CF, CH	-	0,7	XR5	3332	XR5IX	7355
Four 50	-	0,9	BR6S	3522		
Four 90	-	0,7	AB-6	2910		
Six 116/140/150/160	-	0,7	AB-6	2910		
Six 232 Stern Drive	-	0,9	GR5	2851	GR5IX	7214
Super 330	-	0,7	AB-6	2910		

LUGGER

Four 22	-	0,7	AB-7	3010		
Four 40	-	0,7	AB-6	2910		
Four 52	-	0,7	AB-7	3010		
Four 69	-	0,9	BR6S	3522		
Four 75	-	0,7	AB-6	2910		
Four 80	-	0,7	AB-6	2910		
Four 85TD	-	0,7	AB-6	2910		
Four 112	-	0,7	AB-7	3010		
Four 140	-	0,7	AB-6	2910		
Four 162	-	0,7	AB-6	2910		
Seascout 45	-	0,9	BR6S	3522		
Seascout 91	-	0,9	BR6S	3522		
Six 51	-	0,7	AB-7	3010		
Six 71/77/91	-	0,7	AB-6	2910		
Six 121/186/226	-	0,7	AB-7	3010		
Six 244	-	0,7	AB-6	2910		
Six 330	-	0,7	AB-7	3010		

PHANTOM

Four 45	-	0,9	BR6S	3522		
Four 62/75/85/86/162/620/750	-	0,7	AB-6	2910		
Six 70/80/88/90	-	0,7	AB-6	2910		
Six 100/103/104/109	-	0,7	AB-6	2910		
Six 109TD	-	0,7	AB-6	2910		
Six 110/112/115/116/118	-	0,7	AB-6	2910		
Six 120/122/125	-	0,7	AB-6	2910		
Six 135	-	0,7	AB-8	7909		
Six 136	-	0,7	AB-6	2910		
Six 150/165/175/185	-	0,7	AB-6	2910		
Six 200	-	0,7	AB-8	7909		

GREEN HERON BOAT WORKS

Mercury Sportjet 90 - 718cc	-	1,0	BR7HS-10	1098		
-----------------------------	---	-----	----------	------	--	--

GUARDIAN MARINE**CHEVROLET**

454 cid	-	1,1	UR4	6630	UR4IX	7401
---------	---	-----	-----	------	-------	------

FORD

302 cid	-	0,9	UR5	2771	UR5IX	7177
351W cid	-	0,9	UR5	2771	UR5IX	7177
460 cid	-	0,9	UR5	2771	UR5IX	7177

C
Y
I

Stock-Nº



Stock-NºX

OLDSMOBILE

455 cid	-	0,9	XR4	5858	XR4IX	7189
---------	---	-----	-----	------	-------	-------------

HARDIN

H225IO/J/V	1980 - 1986	0,9	YR5	7052	YR5IX	7516
H240J	1969 - 1990	0,9	XR5	3332	XR5IX	7355
H240J (Tapered seat)	1969 - 1990	0,9	UR5	2771	UR5IX	7177
H240V	1969 - 1990	0,9	XR5	3332	XR5IX	7355
H240V (Tapered seat)	1969 - 1990	0,9	UR5	2771	UR5IX	7177
H260IO/J/V	1980 - 1986	0,9	YR5	7052	YR5IX	7516
H280	1980 - 1986	0,9	YR5	7052	YR5IX	7516
H280J/V	1980 - 1986	0,9	YR5	7052	YR5IX	7516
H295J/V	1960 - 1976	0,9	XR5	3332	XR5IX	7355
H300J/V	1977 - 1990	0,9	XR5	3332	XR5IX	7355
H305I	1979 - 1990	0,9	YR5	7052	YR5IX	7516
H320J/V	1979 - 1990	0,9	YR5	7052	YR5IX	7516
H320TC	1978 - 1990	0,7	R5673-7	4367		
H324J/V	1975 - 1976	0,9	XR5	3332	XR5IX	7355
H325J/V	1969 - 1976	0,8	XR5	3332	XR5IX	7355
H333J/V	1976 - 1990	0,9	YR5	7052	YR5IX	7516
H345J/V	1969 - 1976	0,8	XR5	3332	XR5IX	7355
H350I	1979 - 1990	0,9	YR5	7052	YR5IX	7516
H405J	1974 - 1990	0,9	YR5	7052	YR5IX	7516
H405TC	1978 - 1990	0,7	B7HS	5110	BR7HIX	7067
H405V	1974 - 1990	0,9	YR5	7052	YR5IX	7516
H454I	1979 - 1990	0,9	YR5	7052	YR5IX	7516
H455J (ET)	1976 -	0,9	XR5	3332	XR5IX	7355
H455V (ET)	1976 -	0,9	XR5	3332	XR5IX	7355
HM225/260/280/333	1983 - 1990	0,9	UR5	2771	UR5IX	7177
HM400/405/403	1983 - 1990	0,9	UR5	2771	UR5IX	7177

HARMAN HOUSE**CHEVROLET**

3.5 hp - 454 cid Engs.	-	0,9	BPR4FS	1127	UR4IX	7401
5 hp - 454 cid Engs.	-	0,9	BPR4FS	1127	UR4IX	7401
15 hp - 350 cid Engs.	-	1,0	BR5FS	4123		

FORD

7 hp - 460 cid Engs.	-	0,9	BR5FS	4123		
----------------------	---	-----	-------	------	--	--

HOBIE

Mercury Sportjet 90 - 718cc	-	1,0	BZ7HS-10	3579		
Mercury Sportjet 95XR - 782cc	-	1,0	BZ7HS-10	3579		
Mercury Sportjet 90 - 782cc	-	1,0	BZ7HS-10	3579		

HOBLE

Mercury Sportjet 90 - 785cc	-	1,0	BZ7HS-10	3579		
-----------------------------	---	-----	----------	------	--	--

C
Y
I

Stock-Nº



Stock-NºX

HOLDEN

All Flat End Models (Short)		-		0,8	BP5S	3011	XR5IX	7355
All Flat End Models (long)		-		0,9	BP6ES	7811	BPR6EIX	6637
All models tapered seat (Short)		-		0,9	BP6FS	3512	UR6IX	7348
All models tapered seat (long)		-		0,9	BP6EFS	3812	TR6IX	3689

HOVER AIR AMERICA

3 Plus 1 - 4.3L Mercruiser		-		0,9	BPR4FS	1127	UR4IX	7401
50 hp - 951cc		-		1,0	BR9ES	5722	BR9EIX	3981

HUMBOLT MARINE SERVICES**OMC**

OMC Turbojet 115 - 951cc		-		0,8	BZ7HS-10	3579		
--------------------------	--	---	--	-----	----------	------	--	--

MERCURY

Mercury Sportjet 90 - 951cc		-		1,0	BZ7HS-10	3579		
-----------------------------	--	---	--	-----	----------	------	--	--

HUSTLER

350		-		0,9	BPR6FS	2623	UR6IX	7348
375		-		0,9	BPR6FS	2623	UR6IX	7348
450		-		0,9	BPR6FS	2623	UR6IX	7348
525		-		0,9	BPR6FS	2623	UR6IX	7348
585		-		0,9	BPR6FS	2623	UR6IX	7348

HYDROFORCE

Mercury Sportjet 90 - 951cc		-		1,0	BZ7HS-10	3579		
Mercury Sportjet 120XR - 951cc		-		1,0	BZ7HS-10	3579		

IMC

5.0 hp - Jet & Personal Watercraft - 800 cc		-		0,8	BR9ES	5722	BR9EIX	3981
7.5 hp - Jet & Personal Watercraft - 800 cc		-		0,8	BR9ES	5722	BR9EIX	3981
5.0 hp - Jet & Personal Watercraft - 1300 cc		-		0,8	BR9ES	5722	BR9EIX	3981
7.5 hp - Jet & Personal Watercraft - 1300 cc		-		0,8	BR9ES	5722	BR9EIX	3981

INDMAR**CADILLAC**

4.6L MPI Northstar - 279 cid		-		1,5	TR55	3951	TR55IX	7164
------------------------------	--	---	--	-----	------	------	--------	-------------

FORD

5.0L V8 200 - 302 cid	8	1991 - 1995		1,1	UR5	2771	UR5IX	7177
5.0L V8 225 - 302 cid	8	1991 - 1997		0,9	UR5	2771	UR5IX	7177
5.8L V8 - 351 cid	8	1983 - 1987		0,9	AR6FS	3323		
5.8L V8 250 - 351 cid	8	1991 - 1997		0,9	UR5	2771	UR5IX	7177
5.8L V8 285 H.O.- 351 cid	8	1991 - 1997		1,1	BPR6EFS	3623	TR6IX	3689
7.5L V8 - 460 cid	8	1976 - 1984		0,9	UR5	2771	UR5IX	7177

GM

3.0L	4	-		0,9	BR6FS	4323	BR6FIX	2318
4.3L V6 EFI	6	-		1,1	BR6FS	4323	BR6FIX	2318



C
Y
I



Stock-No

FRIDIUM

Stock-NoX

5.0L V8 230 - Small Block	8	-		1,1	BR6FS	4323	BR6FIX	2318
5.0L V8 230SP - Small Block	8	-		1,1	BR6FS	4323	BR6FIX	2318
5.7L LS1 Corvette - Small Block	8	-		0,9	TR4	3754	TR4IX	7300
5.7L V8 - Small Block	8	1976-1987		1,0	UR5	2771	UR5IX	7177
5.7L V8 Carb - Small Block	8	-		1,1	BR6FS	4323	BR6FIX	2318
5.7L V8 Carb H.O. - Small Block	8	-		1,1	BPR6EFS	3623	TR6IX	3689
5.7L V8 EFI - Small Block	8	-		1,1	BR6FS	4323	BR6FIX	2318
5.7L V8 EFI H.O. - Small Block	8	-		1,1	BPR6EFS	3623	TR6IX	3689
5.7L V8 Except LS1 - Small Block	8	1994-2005		1,0	TR5	2238	TR5IX	7397
5.7L V8 Gen 1+ Carb - Small Block	8	-		1,1	BPR6EFS	3623	TR6IX	3689
5.7L V8 Gen 1+ H.O. Carb - Small Block	8	-		1,1	BPR6EFS	3623	TR6IX	3689
5.7L V8 Gen 1+ H.O. PFI - Small Block	8	-		1,1	BPR6EFS	3623	TR6IX	3689
5.7L V8 Indmar TBI - Small Block	8	-		1,1	BR6FS	4323	BR6FIX	2318
5.7L V8 LS1 - Small Block	8	1994-2002		1,2	TR55	3951	TR55IX	7164
5.7L V8 LS1 - Small Block	8	2003-2005		1,5	TR55	3951	TR55IX	7164
5.7L V8 LT-1 - Small Block	8	-		1,1	BPR6EFS	3623	TR6IX	3689
6.0L V8 - GM Big Block	8	2003-2005		1,5	TR55	3951	TR55IX	7164
6.6L V8 - Small Block	8	-		1,1	BR6FS	4323	BR6FIX	2318
7.4L V8 - GM Big Block	8	1998-1999		1,1	BPR6EFS	3623	TR6IX	3689
7.4L V8 - GM Big Block	8	2003-2005		1,1	TR5	2238	TR5IX	7397
7.4L V8 Carb - GM Big Block	8	-1997		1,1	BR6FS	4323	BR6FIX	2318
7.4L V8 Carb H.O. - GM Big Block	8	-1997		1,1	BR6FS	4323	BR6FIX	2318
7.4L V8 EFI - GM Big Block	8	-1997		1,1	BR6FS	4323	BR6FIX	2318
7.4L V8 EFI H.O. - GM Big Block	8	-1997		1,1	BR6FS	4323	BR6FIX	2318
7.4L V8 H.O. - GM Big Block	8	-1997		1,1	BPR6EFS	3623	TR6IX	3689
8.1L MPI Vortec - GM Big Block	8	2003-2005		1,5	TR55	3951	TR55IX	7164
8.2L V8 - GM Big Block	8	-1997		1,1	BR6FS	4323	BR6FIX	2318
8.2L V8 - GM Big Block	8	1998-1999		1,1	BPR6EFS	3623	TR6IX	3689
8.2L V8 - GM Big Block	8	2003-2005		1,1	TR5	2238	TR5IX	7397
8.2L V8 H.O. - GM Big Block	8	-1997		1,1	BR6FS	4323	BR6FIX	2318

OLDSMOBILE

350 cid 5.7L V8	8	1976-1982		1,0	XR4	5858	XR4IX	7189
403 cid 6.6L V8	8	1976-1982		1,0	XR4	5858	XR4IX	7189
455 cid 7.5L V8	8	1975-1976		1,0	XR4	5858	XR4IX	7189

INTERCEPTOR

104 V4	4	-		0,8	BP7HS	5111	BPR7HIX	5944
122 V6	6	-		0,8	BP7HS	5111	BPR7HIX	5944
144		-		0,8	AP5FS	2610	WR5IX	7510
144 (heavy use)		-		0,8	AP6FS	2710		
170/200/256		-		0,8	A6FS	2210		
260		-		0,8	AP7FS	2127		
270		-		0,8	AP5FS	2610	WR5IX	7510
272/289/292		-		0,8	A6FS	2210		
302		-		0,8	AP6FS	2710		
312		-		0,8	A6FS	2210		
352		-		0,8	A6FS	2210		
390		-		0,8	AP6FS	2710		
427 - 300 hp		-		0,8	A6FS	2210		
427 - 400 hp		-		0,8	AP6FS	2710		

C
Y
I

Stock-Nº



Stock-NºX

JET NAUTICA

Mercury Sportjet 90 - 1494cc	-	1,0	BZ7HS-10	3579		
Mercury Sportjet 120XR - 1494cc	-	1,0	BZ7HS-10	3579		

JET SKATE

50 hp - Brute - 1494cc	-	0,9	BR8ES	5422	BR8EIX	5044
------------------------	---	-----	-------	------	--------	-------------

JET SPORT

55 hp - Mercury Sportjet 90XR	-	0,8	BZ7HS-10	3579		
60 hp - Mercury Sportjet 120XR	-	0,8	BZ7HS-10	3579		
55 hp - Mercury Sportjet 90XR	-	0,8	BZ7HS-10	3579		
60 hp - Mercury Sportjet 120XR	-	0,8	BZ7HS-10	3579		

JET STAR

65 hp - Suzuki Engine	-	0,8	BR6HS	3922	BR6HIX	3419
-----------------------	---	-----	-------	------	--------	-------------

JET-N-SPRAY

50 hp - Yamaha Engine Twin - 951cc	-	1,0	BR7HS-10	1098		
63 hp - Yamaha Engine Twin - 951cc	-	1,0	BR7HS-10	1098		

JET-SLED

OMC Turbojet 115 - 1494cc	-	0,8	BZ7HS-10	3579		
---------------------------	---	-----	----------	------	--	--

JOHNSON

SERIE CU

110 hp - 153 cid	-	0,9	B6ES	7310		
120 hp - 153 cid	-	0,9	B6ES	7310		

SERIE DU

88 hp - 89 cid	-	0,8	B8S	3810		
90 hp - 89 cid	-	0,8	B8S	3810		

SERIE HU

150 hp - 225 cid	-	0,9	BP6S	3111		
155 hp - 225 cid	-	0,9	BP6S	3111		

SERIE KU

185 hp - 283 cid	-	0,9	B6S	3510		
------------------	---	-----	-----	------	--	--

SERIE NU

80 hp - 1600cc	-	0,8	BP6ES	7811	BPR6EIX	6637
90 hp - 1600cc	-	0,8	BP6ES	7811	BPR6EIX	6637

SERIE SU

110 hp - 153 cid	-	0,9	B6ES	7310		
120 hp - 153 cid	-	0,9	B6ES	7310		

KLAMATH

70 hp - OMC Turbojet 115	-	1,0	BZ7HS-10	3579		
--------------------------	---	-----	----------	------	--	--

C
Y
I

Stock-Nº

FRIDUM

Stock-NºX

KODIAK

3.0L L4 140 hp - 181 cid		1999-2000		1,1	UR4	6630	UR4IX	7401
4.3L V6 220 hp - 262 cid	6	1999-2000		1,1	BR6FS	4323	BR6FIX	2318
5.7L V8 310 hp - 350 cid	8	1999-2000		1,1	TR5	2238	TR5IX	7397
7.4L V8 350 hp - 454 cid	8	1999-2000		1,1	BR6FS	4323	BR6FIX	2318

LEHMAN ECON-O-POWER

CHEVROLET

135 hp - 307 cid		1971-1973		0,9	BPR5FS	2423	UR5IX	7177
150 hp - 350 cid		1973-1988		0,9	BPR4FS	1127	UR4IX	7401
200 hp - 400 cid		1971-1973		0,9	BPR4FS	1127	UR4IX	7401
225 hp - 283 cid		1957-1970		0,9	BP5S	3011	XR5IX	7355
225 hp - 307 cid		1957-1970		0,9	BP5S	3011	XR5IX	7355
225 hp - 327 cid		1957-1970		0,9	BP5S	3011	XR5IX	7355
225 hp - 350 cid		1957-1970		0,9	BP5S	3011	XR5IX	7355
225 hp - 400 cid		1957-1970		0,9	BP5S	3011	XR5IX	7355

FORD

20 hp - 115 cid (Capri)	6	1972-1973		0,9	BPR6ES	7822	BPR6EIX	6637
25 hp - 170 cid	6	1960-1973		0,9	AR6FS	3323		
30 hp - 200 cid	6	1960-1973		0,9	AR6FS	3323		
30 hp - 240 cid	6	1960-1973		0,9	AR6FS	3323		
30 hp - 250 cid	6	1960-1973		0,9	AR6FS	3323		
30 hp - 300 cid	6	1960-1973		0,9	AR6FS	3323		
40 hp - 260 cid	8	1963-1968		0,9	AR6FS	3323		
40 hp - 289 cid	8	1963-1968		0,9	AR6FS	3323		
45 hp - 292 cid	8	1956-1962		0,9	APR6FS	2922		
45 hp - 312 cid	8	1956-1962		0,9	APR6FS	2922		
50 hp - 302 cid (14mm)	8	1969-1971		0,9	BR6FS	4323	BR6FIX	2318
75 hp - 302 cid (18mm)	8	1968-1973		0,9	APR6FS	2922		
75 hp - 351 cid (18mm)	8	1968-1973		0,9	APR6FS	2922		
90 hp - 390 cid	8	1958-1968		0,9	AR6FS	3323		
90 hp - 410 cid	8	1958-1968		0,9	AR6FS	3323		
90 hp - 427 cid	8	1958-1968		0,9	AR6FS	3323		
90 hp - 428 cid	8	1958-1968		0,9	AR6FS	3323		
115 hp - 351 cid (14mm)	8	1970-1973		0,9	BR5FS	4123		
115 hp - 429 cid (14mm)	8	1970-1973		0,9	BR5FS	4123		
115 hp - 460 cid (14mm)	8	1970-1973		0,9	BR5FS	4123		
130 hp - 429 cid (18mm)	8	1968-1973		0,9	AR6FS	3323		
130 hp - 460 cid (18mm)	8	1968-1973		0,9	AR6FS	3323		

MARINE DRIVE SYSTEMS

85 Stern Drive		-		0,6	BP7HS	5111	BPR7HIX	5944
110 Stern Drive		-		0,6	BP7HS	5111	BPR7HIX	5944

MARINE POWER

L4

181 cid 3.0L	4	1975-1978		0,9	BR6ES	4922		
181 cid 3.0L Tapered seat	4	1975-1991		0,9	BR6FS	4323	BR6FIX	2318
181 cid 3.0L Tapered seat	4	1992-2000		0,9	BPR6EFS	3623	TR6IX	3689

C
Y
I

Stock-Nº



Stock-NºX

GM

V6 262 cid 4.3L	6	1995 - 1997		0,9	BR6FS	4323	BR6FIX	2318
V6 262 cid 4.3L	6	1998 - 2000		0,9	TR5	2238	TR5IX	7397
V8 305 cid 5.0L - GM Small Block	8	2000 -		0,9	TR5	2238	TR5IX	7397
V8 305 cid 5.0L G, K, LV - GM Small Block	8	1977 - 1986		0,9	BR6FS	4323	BR6FIX	2318
V8 307 cid 5.0L G, K, LV 215 hp - GM Small Block	8	1975 - 1976		0,9	BR6FS	4323	BR6FIX	2318
V8 350 cid 5.7L - GM Small Block	8	1992 - 1997		0,9	BR6FS	4323	BR6FIX	2318
V8 350 cid 5.7L - GM Small Block	8	1998 - 2000		0,9	TR5	2238	TR5IX	7397
V8 350 cid 5.7L FLV 300 hp - GM Small Block	8	1975 - 1986		0,9	BR6FS	4323	BR6FIX	2318
V8 350 cid 5.7L FLV, GLV, K 250 hp - GM Small Block	8	1975 - 1986		0,9	BR6FS	4323	BR6FIX	2318
V8 350 cid 5.7L Premium - GM Small Block	8	1992 - 1997		0,9	BPR6EFS	3623	TR6IX	3689
V8 350 cid 5.7L Q Series - GM Small Block	8	1979 - 1991		0,9	BR6FS	4323	BR6FIX	2318
V8 454 cid 7.4L - GM Big Block	8	1992 - 1997		0,9	BR6FS	4323	BR6FIX	2318
V8 454 cid 7.4L - GM Big Block	8	1998 - 2000		0,9	BR6FS	4323	BR6FIX	2318
V8 454 cid 7.4L (L29) - GM Big Block	8	2000 -		0,9	BPR6EFS	3623	TR6IX	3689
V8 454 cid 7.4L B, BM 330 hp - GM Big Block	8	1975 - 1991		0,9	BR6FS	4323	BR6FIX	2318
V8 454 cid 7.4L Premium - GM Big Block	8	1992 - 1997		0,9	BR6FS	4323	BR6FIX	2318
V8 502 cid 8.2L - GM Big Block	8	1995 - 1997		0,9	BR6FS	4323	BR6FIX	2318
V8 502 cid 8.2L Premium - GM Big Block	8	1995 - 1997		0,9	BR6FS	4323	BR6FIX	2318
V8 540 cid 8.9L 550 hp - GM Big Block	8	1995 - 1997		0,9	BR6FS	4323	BR6FIX	2318

MARINETEK**CHRYSLER**

318 cid		1966 - 1974		1,0	XR4	5858	XR4IX	7189
318 cid		1975 - 1988		0,9	BPR5ES	7422	BPR5EIX	6597
360 cid		1975 - 1988		0,9	BPR5ES	7422	BPR5EIX	6597

FORD

302 cid		1968 - 1974		0,9	WR5	2438	WR5IX	7510
302 cid		1975 - 1980		0,9	UR5	2771	UR5IX	7177
302 cid		1981 - 1995		1,1	UR4	6630	UR4IX	7401
351 cid		1969 - 1974		0,9	WR5	2438	WR5IX	7510
351 cid		1975 - 1987		0,9	UR5	2771	UR5IX	7177
460 cid		1973 - 1974		0,9	WR5	2438	WR5IX	7510
460 cid		1975 - 1987		0,9	UR5	2771	UR5IX	7177

GM

181 cid 3.0L HO		1990 - 1997		1,1	TR4	3754	TR4IX	7300
229 cid		1980 - 1984		1,1	UR4	6630	UR4IX	7401
250 cid		1970 - 1980		1,1	UR4	6630	UR4IX	7401
262 cid		1985 - 1992		1,1	UR4	6630	UR4IX	7401
305 cid		1976 - 1995		1,1	UR4	6630	UR4IX	7401
350 cid		1967 - 1970		1,0	XR4	5858	XR4IX	7189
350 cid		1971 - 1995		1,1	UR4	6630	UR4IX	7401
350 cid HO		1987 - 1995		0,9	UR5	2771	UR5IX	7177
454 cid		1973 - 1987		1,1	UR4	6630	UR4IX	7401
454 cid Gen V		1992 - 1993		0,9	UR5	2771	UR5IX	7177
454 cid HO		1984 - 1991		0,9	UR5	2771	UR5IX	7177

MARLIN

70 hp - Mercury Sportjet 120XR		-		1,0	BZ7HS-10	3579		
--------------------------------	--	---	--	-----	----------	------	--	--

C
Y
I

Stock-Nr



Stock-NrX

MASSEY INDUSTRIES

75 hp - Mercruiser 5.7 EFI Alpha		-		1,0	BR6FS	4323	BR6FIX	2318
75 hp - Mercury Sportjet 90		-		1,0	BZ7HS-10	3579		
75 hp - Mercury Sportjet 120XR		-		1,0	BZ7HS-10	3579		

MERCURUISER

470	4	-		0,9	BPR6FS	2623	UR6IX	7348
-----	---	---	--	-----	--------	------	-------	-------------

FORD





215	8	-		0,8	AR6FS	3323		
225	8	-		0,8	AR6FS	3323		
233 - Ø14mm	8	-		0,8	BPR6FS	2623	UR6IX	7348
233 - Ø18mm	8	-		0,8	AR6FS	3323		
233 MCM & MIE (350 cid)	8	1975 - 1977		0,8	AR6FS	3323		
255	8	-		0,9	BR6FS	4323	BR6FIX	2318
255 MCM & MIE (350 cid)	8	1973 - 1980		0,8	AR6FS	3323		

GM - BIG BLOCK

325 (--> N°2762441)	8	-		-	BUE	2322		
325 (N°2762442-->)	8	-		0,9	R5673-8	4140		
330 (454 cid)	8	1982 - 1987		0,9	BR6FS	4323	BR6FIX	2318
330 MCM & MIE (454 cid)	8	1977 - 1981		0,9	BR6FS	4323	BR6FIX	2318
330 MCM & MIE (454 cid)	8	1977 - 1981		0,9	R5673-8	4140		
340	8	-		0,9	BR6FS	4323	BR6FIX	2318
340 MIE (454 cid)	8	1981 - 1987		0,9	BR6FS	4323	BR6FIX	2318
350	8	-		0,9	R5673-8	4140		
350 MIE (454 cid)	8	1974 - 1976		0,9	R5673-8	4140		
390	8	-		0,9	BPR8ES	3923		
400 Jet	8	-		0,9	BR6FS	4323	BR6FIX	2318
454 EFI MP	8	-		1,0	BR6FS	4323	BR6FIX	2318
454 Mag MPI (N°0L002200-->)	8	-		0,9	BR6FS	4323	BR6FIX	2318
454 MPI	8	-		1,0	BR6FS	4323	BR6FIX	2318
7.4L	8	-		1,0	BR6FS	4323	BR6FIX	2318
7.4L EFI	8	-		1,0	BR6FS	4323	BR6FIX	2318
7.4L EFI / MPI	8	-		1,0	BR6FS	4323	BR6FIX	2318
7.4L MPI (N°0L002006-->)	8	-		1,1	BPR6EFS	3623	TR6IX	3689
7.4L MPI (-->N°0L000000)	8	-		1,0	BR6FS	4323	BR6FIX	2318
8.1S HO	8	2000 - 2006		1,5	TR55	3951	TR55IX	7164
8.1S HO	8	2007 -		0,8	IZFR7M	4214		
8.1S Horizon	8	2000 - 2006		1,5	TR55	3951	TR55IX	7164
8.1S Horizon	8	2007 -		0,8	IZFR7M	4214		
8.2L	8	-		1,0	BR6FS	4323	BR6FIX	2318
8.2L MPI	8	-		1,0	BR6FS	4323	BR6FIX	2318

GM - SMALL BLOCK

198	8	-		0,9	YR5	7052	YR5IX	7516
225	8	-		0,8	B7S	3710		
228	8	-		0,9	YR5	7052	YR5IX	7516
230	8	-		0,9	YR5	7052	YR5IX	7516
250 (N°2317201 -->N°2797056)	8	-		1,0	B7S	3710		
255	8	-		0,9	BR6FS	4323	BR6FIX	2318
260	8	-		0,9	BR6FS	4323	BR6FIX	2318
270	8	-		0,9	B7S	3710		
270 - Tapered seat	8	-		0,9	R5673-8	4140		

	C Y I					Stock-N°	<i>TRABUM</i>	Stock-N°X
350 Mag	8	-		1,0	BR6FS	4323	BR6FIX	2318
350 Mag Alpha	8	1986-1997		0,9	BR6FS	4323	BR6FIX	2318
350 Mag Alpha EFI (Gen+)	8	-		1,1			TR5IX	7397
350 Mag Bravo MPI	8	-		0,9	BR6FS	4323	BR6FIX	2318
350 Mag Bravo MPI (Gen+)	8	1996-1997		1,1			TR5IX	7397
350 Mag EFI (-->N°0F799999)	8	-		1,0	BR6FS	4323	BR6FIX	2318
350 Mag EFI Gen+ (N°0F800000-->)	8	-		1,1	BPR6EFS	3623	TR6IX	3689
350 Mag EFI/MP (-->N°0F799999)	8	-		1,0	BR6FS	4323	BR6FIX	2318
350 Mag EFI Ski	8	1994-1996		1,1	BPR6EFS	3623	TR6IX	3689
350 Mag EFI Ski (Gen+)	8	1996-1997		1,1	BPR6EFS	3623	TR6IX	3689
350 Mag MPI	8	2002-		1,5	ITR4A15	5599		
350 Mag MPI	8	2007-		0,8	IZFR7M	4214		
350 Mag MPI (N°0L304700-->)	8	2000-2006		0,9	TR5	2238	TR5IX	7397
350 Mag MPI (-->N°0F799999)	8	2000-2006		1,0	BR6FS	4323	BR6FIX	2318
350 Mag MPI EC	8	2008-		1,5	ITR4A15	5599		
350 Mag MPI Gen+ (0L002600-0L309999)	8	-		1,1	BPR6EFS	3623	TR6IX	3689
350 Mag MPI Gen+ (N°0M310000-->)	8	-		1,5	TR55	3951	TR55IX	7164
350 Mag MPI Horizon	8	2002-2007		1,5	ITR4A15	5599		
350 Mag MPI Horizon	8	2007-		0,8	IZFR7M	4214		
350 Mag MPI Horizon MIE	8	1999-2001		1,1			TR5IX	7397
350 Mag MPI Horizon MIE	8	2002-2007		1,5	ITR4A15	5599		
350 Mag MPI MIE	8	2002-2007		1,5	ITR4A15	5599		
350 Mag MPI MIE (Gen+)	8	1998-2001		1,1			TR5IX	7397
350 Mag MPI Ski	8	1995-1996		0,9	BR6FS	4323	BR6FIX	2318
350 Mag MPI Ski	8	2001-2004		1,5			TR55IX	7164
350 Mag MPI Ski (Gen+)	8	1998-2001		1,1	BPR6EFS	3623	TR6IX	3689
350 Mag Ski	8	1991-1997		0,9	BR6FS	4323	BR6FIX	2318
454 EFI/MP	8	-		1,0	BR6FS	4323	BR6FIX	2318
454 MPI	8	-		1,0	BR6FS	4323	BR6FIX	2318
5.0L	8	-		0,9	YR5	7052	YR5IX	7516
5.0L MPI	8	-		1,0	BR6FS	4323	BR6FIX	2318
5.7L	8	1988-1997		1,0	BR6FS	4323	BR6FIX	2318
5.7L	8	2007-		0,8	IZFR7M	4214		
5.7L (-->N°0L000000)	8	-		1,0	BR6FS	4323	BR6FIX	2318
5.7L Comp (-->N°0L000000)	8	-		1,0	BR6FS	4323	BR6FIX	2318
5.7L Comp Gen+ (N°0L002005-->)	8	-		1,1	BPR6EFS	3623	TR6IX	3689
5.7L EFI Gen+ (N°0L010035-->)	8	-		1,1	BPR6EFS	3623	TR6IX	3689
5.7L Gen+ (N°0L010037-->)	8	-		1,1	BPR6EFS	3623	TR6IX	3689
5.7L MIE	8	1993-1995		0,9	BR6FS	4323	BR6FIX	2318
5.7L MIE (Gen+)	8	1998-		1,1			TR5IX	7397
5.7L MIE (LH)	8	1988-1993		0,9	BR6FS	4323	BR6FIX	2318
5.7L MIE (RH)	8	1988-1993		0,9	BR6FS	4323	BR6FIX	2318
5.7 MPI Horizon MIE	8	2008-		1,5	ITR4A15	5599		
5.7 MPI MIE	8	2008-		1,5	ITR4A15	5599		
5.7 MPI MIE EC	8	2008-		1,5	ITR4A15	5599		
5.7 MPI Tow Sports	8	2008-		1,5	ITR4A15	5599		
5.7 MPI Tow Sports EC	8	2008-		1,5	ITR4A15	5599		
5.7L Ski	8	1985-1997		0,9	BR6FS	4323	BR6FIX	2318
5.7L Ski	8	1998-		1,1			TR5IX	7397
Black Scorpion 5.7L	8	2007-		0,8	IZFR7M	4214		
Black Scorpion 5.7L (N°0F800000-->)	8	2000-2006		1,1	BPR6EFS	3623	TR6IX	3689
Black Scorpion 5.7L (N°0M391852-->)	8	2000-2006		1,5	TR55	3951	TR55IX	7164
Black Scorpion Ski (Gen+)	8	1996-2002		1,1			TR5IX	7397

C
Y
I

Stock-Nº

TRADITION

Stock-NºX







Black Scorpion Ski (Gen+)	8	2003-2007		1,5	ITR4A15	5599		
Black Scorpion MX 6.2	8	2000-2006		0,9	TR5	2238	TR5IX	7397
Black Scorpion MX 6.2	8	2007-		0,8	IZFR7M	4214		
Black Scorpion MX 6.2 (N°0M391778-->)	8	2000-2006		1,5	TR55	3951	TR55IX	7164
MX 6.2 MPI	8	2007-		0,8	IZFR7M	4214		
MX 6.2 MPI (-->N°0M320614)	8	2000-2006		1,5	TR55	3951	TR55IX	7164
MX 6.2 MPI (N°M320613-->)	8	2000-2006		1,1	BPR6EFS	3623	TR6IX	3689
MX 6.2 MPI Horizon (N°0M320614-->)	8	2000-2006		1,5	TR55	3951	TR55IX	7164
MX 6.2 MPI Horizon (N°0M320614-->)	8	2007-		0,8	IZFR7M	4214		
MX 6.2L MPI (377cid)	8	2000-2001		1,1			TR5IX	7397
MX 6.2L MPI (377cid)	8	2002-2007		1,5	ITR4A15	5599		
MX 6.2L MPI Horizon (377cid)	8	2002-2007		1,5	ITR4A15	5599		
MX 6.2L MPI Horizon MIE (377cid)	8	2002-		1,5	ITR4A15	5599		
MX 6.2L MPI MIE (377cid)	8	1999-2001		1,1			TR5IX	7397
MX 6.2L MPI MIE (377cid)	8	2002-2007		1,5	ITR4A15	5599		
MX 6.2L MPI MIE EC (377cid)	8	2008-		1,5	ITR4A15	5599		
MX 6.2L MPI Ski (377cid)	8	2002-2007		1,5	ITR4A15	5599		
Scorpion 350	8	2008-		1,5	ITR4A15	5599		
Scorpion 350 EC	8	2008-		1,5	ITR4A15	5599		
Scorpion 377	8	-		1,1	BPR6EFS	3623	TR6IX	3689
Scorpion 377	8	2008-		1,5	ITR4A15	5599		
Scorpion 377 HO EC	8	2009-		1,5	ITR4A15	5599		
Scorpion 377 MCM	8	1999-2005		1,1			TR5IX	7397
Scorpion 377 Ski	8	1997-1998		1,1			TR5IX	7397

CHEVROLET L-6

140	6	-		0,9	BR6ES	4922		
150	6	1964-1966		0,9	BR6ES	4922		
GK	6	-		0,9	BR6ES	4922		
160 - 250 cid	6	1967-1969		0,9	BR6ES	4922		
165 (-->N°2771483)	6	1970-1970		0,9	BR6ES	4922		
165 (N°2771484-->)	6	1971-1981		0,9	BR6FS	4323	BR6FIX	2318
200 - 292 cid	6	-		0,9	BR6ES	4922		
4.3L (-->N°0F802999)	6	-		1,0	BR6FS	4323	BR6FIX	2318
4.3L EFI Gen+ (N°0L012009-->)	6	-		1,1	BPR6EFS	3623	TR6IX	3689
4.3L Gen+ (N°0L010065-->)	6	-		1,1	BPR6EFS	3623	TR6IX	3689
4.3L MPI Gen+ (N°0M322781-->)	6	-		1,5			TR55IX	7164
4.3LH EFI Gen+ (N°0L010044-->)	6	-		1,1	BPR6EFS	3623	TR6IX	3689
4.3LX (-->N°0F001219)	6	1988-1993		0,9	BR6FS	4323	BR6FIX	2318
4.3LX (-->N°0F802999)	6	1993-1996		1,0	BR6FS	4323	BR6FIX	2318
4.3LX Gen+ (N°0F803000 -->N°0L000000)	6	1996-1997		1,1	BPR6EFS	3623	TR6IX	3689
4.3LXH Gen+ (N°0F803000 --> N°0L000000)	6	1996-1997		1,1	BPR6EFS	3623	TR6IX	3689
175 - 262 cid	6	-		0,9	BR6FS	4323	BR6FIX	2318
185	6	-		0,9	BR6FS	4323	BR6FIX	2318
185 (229 cid)	6	-		0,9	BR6FS	4323	BR6FIX	2318
205 - 262 cid	6	1985-1987		0,9	BR6FS	4323	BR6FIX	2318
262 Mag EFI Gen+ (N°0F803800-->N°0L000000)	6	-		1,1	BPR6EFS	3623	TR6IX	3689

CHEVROLET BIG BLOCK

7.4L Alpha	8	-		0,9	BR6FS	4323	BR6FIX	2318
7.4L Bravo	8	1988-1997		1,0	BR6FS	4323	BR6FIX	2318
7.4L EFI MIE	8	1996-1997		1,0	BR6FS	4323	BR6FIX	2318
7.4L MIE	8	1981-1997		0,9	BR6FS	4323	BR6FIX	2318
7.4L MPI (L29) (N°0L010003-->)	8	1998-2001		1,1	BPR6EFS	3623	TR6IX	3689
7.4L MPI MIE	8	1995-1997		0,9	BR6FS	4323	BR6FIX	2318

	C					Stock-Nº		Stock-NºX
7.4L MPI MIE (L29)	8	1998-2001		1,1	BPR6EFS	3623	TR6IX	3689
7.4LX Bravo EFI	8	1996-1997		0,9	BR6FS	4323	BR6FIX	2318
7.4LX Bravo MPI	8	1996-1997		0,9	BR6FS	4323	BR6FIX	2318
7.4LX EFI	8	-		1,0	BR6FS	4323	BR6FIX	2318
7.4LX MPI	8	-		1,0	BR6FS	4323	BR6FIX	2318
7.4L TR (N°0B771113 -->N°0C407646)	8	-		0,9	BR6FS	4323	BR6FIX	2318
325 (-->N°2761141)	8	-		-	BUE	2322		
325 (N°3043030-->)	8	-		0,9	R5673-8	4140		
330	8	-		0,9	BR6FS	4323	BR6FIX	2318
330 (B-W)	8	-		0,9	BR6FS	4323	BR6FIX	2318
370	8	-		0,9	BR6FS	4323	BR6FIX	2318
390	8	-		0,9	BPR8ES	3923		
400	8	-		0,9	BR6FS	4323	BR6FIX	2318
400 Cyclone	8	-		0,9	BR6FS	4323	BR6FIX	2318
420	8	-		0,9	BR6FS	4323	BR6FIX	2318
440 Cyclone	8	-		0,9	BR6FS	4323	BR6FIX	2318
454 Mag Alpha	8	1986-1988		0,9	BR6FS	4323	BR6FIX	2318
454 Mag Bravo	8	1988-1997		1,0	BR6FS	4323	BR6FIX	2318
454 Mag EFI/MP	8	1994-1996		1,0	BR6FS	4323	BR6FIX	2318
454 Mag EFI Ski	8	1995-1996		0,9	BR6FS	4323	BR6FIX	2318
454 Mag MPI	8	1996-2001		1,0	BR6FS	4323	BR6FIX	2318
454 Mag MPI Horizon (N°0L604250-->)	8	-		1,0	BR6FS	4323	BR6FIX	2318
454 Mag MPI Horizon MIE	8	1998-2001		1,0			BR6FIX	2318
454 Mag MPI Horizon Ski	8	1996-1997		1,0	BR6FS	4323	BR6FIX	2318
460 Cyclone	8	-		0,9	R5673-8	4140		
460 TRS	8	1983-1986		0,9	R5673-8	4140		
475 Turbo	8	-		0,9	R5673-8	4140		
496 Mag	8	-		1,5	TR55	3951	TR55IX	7164
496 Mag HO	8	-		1,5	TR55	3951	TR55IX	7164
496 Mag & HO EC	8	2008-		1,5	PZTR5A-15	7862		
502 Mag	8	1990-1993		1,0	BR6FS	4323	BR6FIX	2318
502 Mag EFI/MP	8	1993-1996		1,0	BR6FS	4323	BR6FIX	2318
502 Mag MPI	8	1996-2001		1,0	BR6FS	4323	BR6FIX	2318
HP425	8	-		0,9	BR6FS	4323	BR6FIX	2318
HP450	8	-		1,0	BR6FS	4323	BR6FIX	2318
HP465	8	-		0,9	BR6FS	4323	BR6FIX	2318
HP500 (502 cid)	8	1994-1998		1,0	BR6FS	4323	BR6FIX	2318
HP500 (502 cid) (Gen+)	8	-		1,0	BR6FS	4323	BR6FIX	2318
HP500 (540 cid)	8	-		0,9	R5673-8	4140		
HP500 EFI (502 cid)	8	1998-2005		1,0	BR6FS	4323	BR6FIX	2318
HP525 EFI (502 cid)	8	-		0,9	BR6ES	4922		
HP525SC (454 cid)	8	1991-1999		0,9	R5673-8	4140		
HP575	8	-		0,9	R5673-8	4140		
HP575 SCi	8	2000-2005		1,0	R5673-8	4140		
HP600SC	8	1991-1993		0,9	BR6FS	4323	BR6FIX	2318
HP600SC	8	1993-1996		0,9	R5673-8	4140		
HP600 SCi	8	-		0,9	BR6ES	4922		
HP700 SCi	8	-		0,9	BR6ES	4922		
HP800SC	8	-		0,9	R5673-8	4140		
HP850 SCi	8	-		0,8	BR9ECS	3570		
HP900SC	8	-		0,6	R5671A-9	7382		
HP900SC (Carter sec)	8	-		0,6	R5671A-9	7382		
HP1075 Sci (Carter sec; N°0M905359-->)	8	-		0,8	BR9ECS	3570		

C
Y
I

Stock-Nº



Stock-NºX

CHEVROLET SMALL BLOCK

5.0L (-->N°0L000000)	8	-		0,9	YR5	7052	YR5IX	7516
5.0L EFI Gen+ (N°0L015751-->)	8	-		1,1	BPR6EFS	3623	TR6IX	3689
5.0L Gen+ (N°L015751-->)	8	-		1,1	BPR6EFS	3623	TR6IX	3689
5.0L MPI Gen+ (N°0M320415-->)	8	-		1,5			TR55IX	7164
5.0LX	8	-		0,9	YR5	7052	YR5IX	7516
5.7L (-->N°0L000000)	8	-		1,0	BR6FS	4323	BR6FIX	2318
5.7L EFI (-->N°0L000000)	8	-		1,0	BR6FS	4323	BR6FIX	2318
5.7L EFI Gen+ (N°0L010035-->)	8	-		1,1	BPR6EFS	3623	TR6IX	3689
5.7L Gen+ (N°0L010037-->)	8	-		1,1	BPR6EFS	3623	TR6IX	3689
5.7LX	8	-		1,0	BR6FS	4323	BR6FIX	2318
5.7LX Bravo EFI (Gen+)	8	1996 - 1997		1,1			TR5IX	7397
5.7LX EFI	8	-		1,0	BR6FS	4323	BR6FIX	2318
5.7LX EFI Gen+	8	-		1,1	BPR6EFS	3623	TR6IX	3689
190	8	-		0,9	XR5	3332	XR5IX	7355
225 (-->N°2278646)	8	-		0,9	B7S	3710		
225 (N°2278647-->)	8	-		0,9	XR5	3332	XR5IX	7355
228	8	-		0,9	YR5	7052	YR5IX	7516
230	8	-		0,9	YR5	7052	YR5IX	7516
250 (-->N°2639854)	8	-		0,8	B7S	3710		
250 (N°4768000-->)	8	-		0,9	BR6FS	4323	BR6FIX	2318
255	8	-		0,9	BR6FS	4323	BR6FIX	2318
260	8	-		0,9	BR6FS	4323	BR6FIX	2318
270	8	-		0,8	B7S	3710		
270 - Tapered seat	8	-		0,9	R5673-8	4140		
280	8	-		0,9	BR6FS	4323	BR6FIX	2318
300 Tempest	8	-		0,9	BR6FS	4323	BR6FIX	2318
320 EFI	8	1987 - 1989		0,9	BR6FS	4323	BR6FIX	2318
350 Mag	8	-		1,0	BR6FS	4323	BR6FIX	2318
350 Mag EFI Gen+ (N°0F800500-->)	8	-		1,1	BPR6EFS	3623	TR6IX	3689
350 Mag MPI Gen+ (N°0F602000-->N°0M320489)	8	-		1,1	BPR6EFS	3623	TR6IX	3689
350 Mag MPI Gen+ (N°0M320590-->)	8	-		1,5	TR55	3951	TR55IX	7164
350 Mag MPI Gen+ Horizon (N°0L304700-->N°0M309999)	8	-		0,9	TR5	2238	TR5IX	7397
350 Mag MPI Gen+ Horizon (N°0M310000-->)	8	-		1,5	TR55	3951	TR55IX	7164
350 Mag EFI/MP (-->N°0F602199)	8	-		1,0	BR6FS	4323	BR6FIX	2318
898, 200	8	-		0,9	YR5	7052	YR5IX	7516
MX 6.2 MPI (-->N°0M320613)	8	-		1,1	BPR6EFS	3623	TR6IX	3689
MX 6.2 MPI (N°0M320614-->)	8	-		1,5	TR55	3951	TR55IX	7164
MX 6.2 MPI Horizon (N°0M320614-->)	8	-		1,5	TR55	3951	TR55IX	7164
Scorpion 377 (N°0L416146-->)	8	-		1,1	BPR6EFS	3623	TR6IX	3689

FORD SMALL BLOCK

215 (302 cid)	8	1970 - 1972		0,8	AR6FS	3323		
225	8	2006 -		0,8	BPR6FS	2623	UR6IX	7348
225 (302 cid)	8	1973 - 1974		0,8	AR6FS	3323		
233 - Ø14mm	8	-		0,8	BPR6FS	2623	UR6IX	7348
233 - Ø18mm	8	-		0,8	AR6FS	3323		
255 (-->N°4175498)	8	-		0,8	BR6FS	4323	BR6FIX	2318
255 (N°4175499-->) - Ø14mm	8	-		0,8	BPR6FS	2623	UR6IX	7348
255 (N°4175499-->) - Ø18mm	8	-		0,8	AR6FS	3323		
888 (N°4169597-->) - Ø14mm	8	-		0,8	BPR6FS	2623	UR6IX	7348
888 (N°4169597-->) - Ø18mm	8	-		0,8	AR6FS	3323		
888 (-->N°4169596)	8	-		0,8	AR6FS	3323		

C
Y
I

Stock-Nº



Stock-NºX

GM

98 cid - 100 Vazer	4	2007 - 2009		0,9	BR9ES	5722	BR9EIX	3981
110	4	1963 - 1966		0,9	BR6ES	4922		
120 (-->N°3825578)	4	1964 - 1974		0,9	BR6ES	4922		
120 (N°3825579-->)	4	1975 - 1986		0,9	BR6FS	4323	BR6FIX	2318
140 (-->N°3826282)	4	1968 - 1974		0,9	BR6ES	4922		
140 (N°3826283-->)	4	1974 - 1986		0,9	BR6FS	4323	BR6FIX	2318
185 - 2 bbl (262 cid)	6	1985 - 1987		0,9	BR6FS	4323	BR6FIX	2318
185 - 4 bbl (229 cid)	6	1983 - 1984		0,9	BR6FS	4323	BR6FIX	2318
190 (283 cid)	8	1963 - 1964		0,9	BR6FS	4323	BR6FIX	2318
198 MIE (305 cid)	8	-		0,9	BR6FS	4323	BR6FIX	2318
200 (305 cid)	8	1985 - 1987		0,9	BR6FS	4323	BR6FIX	2318
225 MIE (327 cid)	8	-		0,8	B8S	3810		
228 (305 cid)	8	1977 - 1984		0,9	BR6FS	4323	BR6FIX	2318
228 MIE (305 cid)	8	1977 - 1980		0,9	BR6FS	4323	BR6FIX	2318
230 (305 cid)	8	1985 - 1987		0,9	BR6FS	4323	BR6FIX	2318
230 MIE (LH) (305 cid)	8	1981 - 1987		0,9	BR6FS	4323	BR6FIX	2318
230 MIE (RH) (305 cid)	8	1981 - 1987		0,9	BR6FS	4323	BR6FIX	2318
250 (350 cid)	8	-		0,9	BR6FS	4323	BR6FIX	2318
250 MCM & MIE (327 cid)	8	1968 - 1969		0,8	B8S	3810		
250 MCM & MIE (350 cid)	8	1975 - 1976		0,9	BR6FS	4323	BR6FIX	2318
260 (350 cid)	8	1978 - 1987		0,9	BR6FS	4323	BR6FIX	2318
260 MIE (350 cid) (LH)	8	1981 - 1987		0,9	BR6FS	4323	BR6FIX	2318
260 MIE (350 cid) (RH)	8	1981 - 1987		0,9	BR6FS	4323	BR6FIX	2318
262 Mag TBI (Gen+)	6	1996 - 1997		1,1			TR5IX	7397
270 MCM & MIE (350 cid)	8	1969 - 1972		0,8	B8S	3810		
280 TRS (350 cid)	8	1975 - 1976		0,9	BR6FS	4323	BR6FIX	2318
300 (300 cid)	8	1985 - 1986		0,9	BR6FS	4323	BR6FIX	2318
370 TRS (454 cid)	8	1978 - 1987		0,9	BR6FS	4323	BR6FIX	2318
370 TRS (454 cid)	8	1978 - 1985		0,9	R5673-8	4140		
400 TRS (454 cid)	8	1980 - 1986		0,9	BR6FS	4323	BR6FIX	2318
400 TRS (454 cid)	8	1980 - 1986		0,9	R5673-8	4140		
420 (454 cid)	8	1987 - 1989		0,9	BR6FS	4323	BR6FIX	2318
425 (454 cid)	8	1990 - 1993		0,9	BR6FS	4323	BR6FIX	2318
440 TRS	8	1983 - 1986		0,9	BR6FS	4323	BR6FIX	2318
440 TRS	8	1983 - 1986		0,9	R5673-8	4140		
500 Bulldog (540 cid)	8	1990 - 1996		0,9	BR6FS	4323	BR6FIX	2318
500 Bulldog (540 cid)	8	1997 - 2001		1,0	BR6FS	4323	BR6FIX	2318
898 (305 cid)	8	1977 - 1984		0,9	BR6FS	4323	BR6FIX	2318
2.5L (153 cid)	4	1987 - 1989		0,9	BR6FS	4323	BR6FIX	2318
3.0L (181 cid) (N°0L010042-->)	4	-		0,9	BPR6EFS	3623	TR6IX	3689
3.0L (181 cid) (-->N°0F353100-->)	4	-		0,9	BR6FS	4323	BR6FIX	2318
3.0L MPI (181 cid)	4	2008 -		1,1			TR5IX	7397
3.0LX	4	1990 - 1991		0,9	BR6FS	4323	BR6FIX	2318
3.0LX	4	1991 - 1997		0,9	BPR6EFS	3623	TR6IX	3689
4.3L (262 cid)	6	1988 - 1992		0,9	BR6FS	4323	BR6FIX	2318
4.3L (262 cid)	6	1993 - 1996		1,0	BR6FS	4323	BR6FIX	2318
4.3L (262 cid) (Gen+)	6	1998 -		1,1			TR5IX	7397
4.3L (262 cid) (Gen+) (TBI)	6	1998 - 2001		1,1			TR5IX	7397
4.3L MPI (262 cid)	6	2002 -		1,5	ITR4A15	5599		
4.3L MPI EC (262 cid)	6	2011 -		1,5	ITR4A15	5599		
5.0L (305 cid)	8	1988 - 1995		0,9	BR6FS	4323	BR6FIX	2318
5.0L (305 cid) (Gen+)	8	1998 -		1,1			TR5IX	7397

C
Y
I

Stock-Nº

FRIBUM

Stock-NºX

5.0L EFI (305 cid) (Gen+)	8	1998-2001		1,1			TR5IX	7397
5.0L LX (305 cid)	8	1988-1995		0,9	BR6FS	4323	BR6FIX	2318
5.0L MIE (305 cid) (LH)	8	-		0,9	BR6FS	4323	BR6FIX	2318
5.0L MIE (305 cid) (RH)	8	-		0,9	BR6FS	4323	BR6FIX	2318
5.0L MPI (305 cid)	8	2002-		1,5	ITR4A15	5599		
5.0L MPI EC (305 cid)	8	2008-		1,5	ITR4A15	5599		
8.1S HO MIE (496 cid)	8	2001-		1,5	PZTR5A-15	7862		
8.1S HO MIE EC (496 cid)	8	2008-		1,5	PZTR5A-15	7862		

MERCURY MARINE

3.7L - 224 cid	4	1988-1989		0,9	BPR6FS	2623	UR6IX	7348
3.7LX- 224 cid	4	1988-1989		0,9	BPR6FS	2623	UR6IX	7348
8.2 Mag	8	2010-		0,9	BPR6ES	7822	BPR6EIX	6637
8.2 Mag EC	8	2010-		0,9	BPR6ES	7822	BPR6EIX	6637
8.2 Mag MIE	8	2010-		0,9	BPR6ES	7822	BPR6EIX	6637
8.2 Mag MIE EC	8	2010-		0,9	BPR6ES	7822	BPR6EIX	6637
8.2 MIE	8	1990-1996		0,9	BR6FS	4323	BR6FIX	2318
8.2 MIE EC	8	2010-		0,9	BPR6ES	7822	BPR6EIX	6637
8.2 MPI MIE	8	1996-2001		1,0	BR6FS	4323	BR6FIX	2318
165 - 224 cid	4	-		0,9	BPR6FS	2623	UR6IX	7348
170 - 224 cid	4	1985-1986		0,9	BPR6FS	2623	UR6IX	7348
180 - 224 cid	4	-		0,9	BPR6FS	2623	UR6IX	7348
190 - 224 cid	4	1985-1986		0,9	BPR6FS	2623	UR6IX	7348
377 Mag (377 cid)	8	2008-		1,5	ITR4A15	5599		
377 Mag EC (377 cid)	8	2008-		1,5	ITR4A15	5599		
470 - 224 cid	4	1976-1984		0,9	BPR6FS	2623	UR6IX	7348
485 - 224 cid	4	1980-1982		0,9	BPR6FS	2623	UR6IX	7348
488 - 224 cid	4	1983-1984		0,9	BPR6FS	2623	UR6IX	7348

RENAULT

60	4	-		0,6	BR6HS	3922	BR6HIX	3419
80	4	-		0,6	BPR6ES	7822	BPR6EIX	6637
90	4	-		0,8	BPR6ES	7822	BPR6EIX	6637

MERCURY

Sport Jet - 90HP		1994-		0,9	BZ7HS-10	3579		
Sport Jet - 90 HP		1995-		1,0	BZ7HS-10	3579		
Sportjet 95XR - 95 HP		1996-1997		1,0	BZ7HS-10	3579		
Sportjet 120 - 120 HP		1995-		1,0	BZ7HS-10	3579		
Sportjet 120XR - 120 HP		1996-1999		0,8	BZ7HS-10	3579		
Sportjet 175XR - 175 HP		1997-2006		-	BUZ8H	7447		
Sport Jet - 200 HP		2006-		0,8	IZFR5G	5887		
M2 Sport Jet - 210 HP		2000-2006		-	BUZ8H	7447		
M2 Sport Jet - 240 HP		2000-2006		1,0	BPZ8HS-10	3133		
M2 Sport Jet - 250 HP		2006-		0,8	IZFR5G	5887		

MID-JET

Mercury Sportjet 90 - 639cc		-		1,0	BZ7HS-10	3579		
Mercury Sportjet 120XR - 644cc		-		1,0	BZ7HS-10	3579		

NAUTICA

Mercury Sportjet 90 - 768cc		-		1,0	BZ7HS-10	3579		
-----------------------------	--	---	--	-----	----------	------	--	--

	C Y I					Stock-Nº		FRIDUM		Stock-NºX	
											
Mercury Sportjet 120XR - 785cc		-			1,0	BZ7HS-10	3579				
Mercury Sportjet 175XR2 - 896cc		-			1,0	BZ7HS-10	3579				
80 hp - 1000cc		-			1,0	BZ7HS-10	3579				
NISSAN											
8.0 hp - HA120		1987-1989			0,9	BR6ES	4922				
NORTH RIVER											
75 hp - Mercruiser 5.7 EFI Alpha		-			1,0	BR6FS	4323	BR6FIX		2318	
NORTHSTAR											
MERCURY											
Mercury Sportjet 90 - 1100cc		-			1,0	BZ7HS-10	3579				
Mercury Sportjet 95XR - 1100cc		-			1,0	BZ7HS-10	3579				
Mercury Sportjet 120XR - 789cc		-			1,0	BZ7HS-10	3579				
Mercury Sportjet 175XR2 - 789cc		-			1,0	BZ7HS-10	3579				
OMC											
120 hp - OMC Turbojet 115		-			0,8	BZ7HS-10	3579				
120 hp - Twin OMC Turbojet 115		-			0,8	BZ7HS-10	3579				
OMC Turbojet 90 - 1231cc		-			0,8	BZ7HS-10	3579				
NOVURANIA											
125 hp - OMC Turbojet 90		-			0,8	BZ7HS-10	3579				
OMC Turbojet 115 - 1231cc		-			0,8	BZ7HS-10	3579				
NU-WAVE											
Mercury Sportjet 90 - 428cc		-			1,0	BZ7HS-10	3579				
Mercury Sportjet 95XR - 432cc		-			1,0	BZ7HS-10	3579				
Mercury Sportjet 120XR - 432cc		-			1,0	BZ7HS-10	3579				
OMC											
AJ - Ø14mm		-			0,9	XR5	3332	XR5IX		7355	
AJ - Ø14mm, Tapered seat		-			0,9	UR5	2771	UR5IX		7177	
AT - Ø14mm		-			0,9	XR5	3332	XR5IX		7355	
AT - Ø14mm, Tapered seat		-			0,9	UR5	2771	UR5IX		7177	
TJ - Ø14mm		-			0,9	XR5	3332	XR5IX		7355	
TJ - Ø14mm, Tapered seat		-			0,9	UR5	2771	UR5IX		7177	
TT - Ø14mm		-			0,9	XR5	3332	XR5IX		7355	
TT - Ø14mm, Tapered seat		-			0,9	UR5	2771	UR5IX		7177	
All models		1974-1982			0,9	UR5	2771	UR5IX		7177	
JET DRIVE											
Turbojet 90		-			0,8	BZ7HS-10	3579				
Turbojet 115		-			0,8	BZ7HS-10	3579				
SAIL DRIVE											
15S10G		1977-1984			1,1	BPR6HS	7022	BPR6HIX		4085	
15S10S		1977-1984			1,1	BPR6HS	7022	BPR6HIX		4085	
15S11C		1977-1984			1,1	BPR6HS	7022	BPR6HIX		4085	

C
Y
I

Stock-Nº



Stock-NºX

15S13A	1977-1984		1,1	BPR6HS	7022	BPR6HIX	4085
15S14M	1977-1984		1,1	BPR6HS	7022	BPR6HIX	4085

SEA DRIVE

1.6L 115-SD	1985-1991		0,8	BZ7HS-10	3579		
1.8L 140-SD	1985-1991		0,8	BZ7HS-10	3579		
2.0L 140-SD	1985-1991		0,8	BZ7HS-10	3579		
2.5L	1981-1984		-	BUHXW-1	5526		
2.6L 190-SD	1985-1988		-	BUHXW-1	5526		
2.7L 225-SD	1987-		0,8	BZ7HS-10	3579		
3.0L 225-SD	1985-1991		0,8	BZ7HS-10	3579		
3.6L 275-SD	1981-1987		0,8	BZ7HS-10	3579		
4.0L 300-SD	1985-1991		0,8	BZ7HS-10	3579		

STERN DRIVE

Ø14mm	1973-1974		0,9	B6ES	7310		
Ø14 mm - Tapered seat	1973-1985		0,9	UR5	2771	UR5IX	7177
Ø18 mm - Tapered seat	1974-1974		0,8	AR6FS	3323		
2.3L Cobra	1987-1990		0,9	TR5	2238	TR5IX	7397
2.5L	1982-1986		0,9	BR6FS	4323	BR6FIX	2318
3.0L	1982-1989		0,9	BR6FS	4323	BR6FIX	2318
3.0L Cobra	1987-1992		1,1	UR4	6630	UR4IX	7401
3.0L Cobra	1993-1998		1,1	TR5	2238	TR5IX	7397
3.0L Cobra HO	1990-1998		1,1	TR5	2238	TR5IX	7397
3.8L	1982-1985		0,9	YR5	7052	YR5IX	7516
4.3L	1991-1993		0,9	BR6FS	4323	BR6FIX	2318
4.3L	1997-1998		0,9	TR4	3754	TR4IX	7300
4.3L - Models 'A'	1996-		0,9	UR4	6630	UR4IX	7401
4.3L - Models 'S'	1996-		0,9	TR4	3754	TR4IX	7300
4.3L Cobra	1986-1995		0,9	UR4	6630	UR4IX	7401
4.3L Cobra HO	1990-1991		0,9	UR4	6630	UR4IX	7401
4.3L Cobra HO	1993-1995		1,1	UR4	6630	UR4IX	7401
4.3L Stinger	1978-1986		0,8	UR4	6630	UR4IX	7401
5.0L	1982-1985		0,9	YR5	7052	YR5IX	7516
5.0L	1998-		0,9	TR4	3754	TR4IX	7300
5.0L Cobra (Carb)	1986-1996		0,9	UR4	6630	UR4IX	7401
5.0L Cobra (EFI)	1996-		0,9	TR4	3754	TR4IX	7300
5.0L Cobra EFI	1993-1995		1,1	TR5	2238	TR5IX	7397
5.0L Cobra HO	1989-1995		0,9	UR4	6630	UR4IX	7401
5.7L	1982-		0,9	BR6FS	4323	BR6FIX	2318
5.7L	1983-		0,9	YR5	7052	YR5IX	7516
5.7L	1984-1985		0,9	BR6FS	4323	BR6FIX	2318
5.7L	1998-		0,9	TR4	3754	TR4IX	7300
5.7L - Model 57FC	1997-		0,9	TR4	3754	TR4IX	7300
5.7L - except model 57FC	1997-		0,9	UR4	6630	UR4IX	7401
5.7L Cobra	1986-1992		0,9	UR4	6630	UR4IX	7401
5.7L Cobra	1996-		0,9	UR4	6630	UR4IX	7401
5.7L K	1993-1995		1,1	UR4	6630	UR4IX	7401
5.7L King Cobra	1986-1992		0,9	UR4	6630	UR4IX	7401
5.8L Cobra (Carb)	1989-1996		0,9	UR4	6630	UR4IX	7401
5.8L Cobra EFI	1992-1996		1,1	TR5	2238	TR5IX	7397
5.8L King Cobra EFI HO	1993-1995		1,1	TR5	2238	TR5IX	7397
7.4L	1997-		1,1	BPR6EFS	3623	TR6IX	3689
7.4L	1998-		0,9	UR4	6630	UR4IX	7401
7.4L - 744 EP & FP modes	1996-		0,9	UR4	6630	UR4IX	7401

C
Y
I

Stock-Nr



Stock-NrX

7.4L - 744 FF & FG modes	1996-		1,1	BPR6EFS	3623	TR6IX	3689
7.4L Cobra (Carb)	1990 - 1995		1,1	UR4	6630	UR4IX	7401
7.4L Cobra (Carb) HO	1991 - 1993		1,1	UR4	6630	UR4IX	7401
7.4L King Cobra	1995-		1,1	UR4	6630	UR4IX	7401
7.4L King Cobra EFI	1995-		1,1	UR4	6630	UR4IX	7401
7.5L Cobra	1986 - 1990		0,9	UR4	6630	UR4IX	7401
8.2L King Cobra	1992 - 1998		1,1	UR4	6630	UR4IX	7401
480	-		0,8	B8S	3810		
CU	-		0,9	B6ES	7310		
DU	-		0,8	B8S	3810		
GU	-		0,9	B6ES	7310		
HU	-		0,9	XR5	3332	XR5IX	7355
JU	-		0,9	BR6FS	4323	BR6FIX	2318
KU	-		0,9	B6S	3510		
LU	-		0,9	B6ES	7310		
NU	-		0,6	BP6ES	7811	BPR6EIX	6637
Stinger	1978 - 1986		0,9	UR4	6630	UR4IX	7401
SU	-		0,9	B6ES	7310		
TU-14	-		0,9	XR5	3332	XR5IX	7355
TU-15	-		0,9	XR5	3332	XR5IX	7355
TU-16	-		0,9	XR5	3332	XR5IX	7355
TU-17	-		0,9	B6S	3510		
TU-20	-		0,9	BR6FS	4323	BR6FIX	2318
TU-21	-		0,9	BR6FS	4323	BR6FIX	2318
VU	-		0,9	B6ES	7310		
WU	-		0,9	BR6FS	4323	BR6FIX	2318
XU-20C	-		0,9	BR6FS	4323	BR6FIX	2318
XU20S	-		0,9	B6S	3510		

PALMER-GREENW.

M196, M265, M392	-		0,8	B6S	3510		
M304, M345, MKIV-115, MKVI-150	-		0,8	B6S	3510		
M549, M345B, M392B	-		0,8	B6S	3510		
MKVIII: 200, 225, 275, 300	-		0,8	B6S	3510		
P302, P351	-		0,8	AP6FS	2710		
PA190, PA220, PA255	-		0,8	AR6FS	3323		
PA350	-		0,8	BPR5FS	2423	UR5IX	7177
PB-V-215 (V-8)	8	-	0,9	B6HS	4510	BR6HIX	3419
PW27 - Ø14mm	-		0,8	BP5S	3011	XR5IX	7355
PW27 - Ø18mm	-		0,8	AB-6	2910		
Y304, Y345, Y392	-		0,8	B6S	3510		

PANTHER

400 Plus C	1976 - 1980		1,1	UR4	6630	UR4IX	7401
400 Plus-F	1976 - 1980		0,8	UR5	2771	UR5IX	7177
500 Plus	1976 - 1980		1,1	UR4	6630	UR4IX	7401
500 Plus-7	1978 - 1980		0,9	R5673-7	4367		
F 110	1978 - 1980		1,1	UR4	6630	UR4IX	7401
F 140	1978 - 1980		1,1	UR4	6630	UR4IX	7401
F 185	1976 - 1980		0,9	BPR5ES	7422	BPR5EIX	6597
F 235	1976 - 1980		0,9	BPR5ES	7422	BPR5EIX	6597

C
Y
I

Stock-Nº



Stock-NºX

M 360	1976-1980		0,9	BPR5ES	7422	BPR5EIX	6597
M 405	1976-1980		1,1	UR4	6630	UR4IX	7401
M 454	1976-1980		1,1	UR4	6630	UR4IX	7401
M 460	1976-1980		0,8	UR5	2771	UR5IX	7177

PCM

5.7L HO MPI	-		1,1	TR4	3754	TR4IX	7300
5.7L HO Ski TBI - 275hp	-		1,1	UR4	6630	UR4IX	7401
5.8L Carburator - 260hp	-		0,7	UR6	7773	UR6IX	7348
5.8L HO MPI - 310hp	-		1,1	TR4	3754	TR4IX	7300
7.4L MPI	-		1,1	TR4	3754	TR4IX	7300
7.4L Carburateur	-		1,1	UR4	6630	UR4IX	7401
7.4L HO TBI - 350hp	-		1,1	UR4	6630	UR4IX	7401
150 cid	-		1,1	UR4	6630	UR4IX	7401
200 cid	-		1,1	UR4	6630	UR4IX	7401
220 cid	-		1,1	UR4	6630	UR4IX	7401
229 cid	-		1,1	UR4	6630	UR4IX	7401
230 cid	-		1,1	UR4	6630	UR4IX	7401
250 cid	-		1,1	UR4	6630	UR4IX	7401
280 cid	-		1,1	UR4	6630	UR4IX	7401
302 cid - Ø14mm	-		1,1	UR4	6630	UR4IX	7401
302 cid - Ø18mm	-		0,8	AR6FS	3323		
305 cid	-		1,1	UR4	6630	UR4IX	7401
350 cid	-		1,1	UR4	6630	UR4IX	7401
351 cid - Ø14mm	-		1,1	UR4	6630	UR4IX	7401
351 cid - Ø18mm	-		0,8	AR6FS	3323		
454 cid	-		1,1	UR4	6630	UR4IX	7401
460 cid - Ø14mm	-		1,1	UR4	6630	UR4IX	7401
460 cid - Ø18mm	-		0,8	AR6FS	3323		

PERFORMANCE JET SYSTEMS

225 hp - Viper 5000	-		0,8	BR8ES	5422	BR8EIX	5044
225 hp - Viper 6000	-		0,8	BR8ES	5422	BR8EIX	5044
225 hp - Viper 7000HT	-		0,8	BR8ES	5422	BR8EIX	5044
225 hp - Viper 8000	-		0,8	BR8ES	5422	BR8EIX	5044
225 hp - Viper 9000HT	-		0,8	BR8ES	5422	BR8EIX	5044

PLAY CRAFT

Mercury Sportjet 90 - 701cc	-		1,0	BZ7HS-10	3579		
Mercury Sportjet 120XR	-		1,0	BZ7HS-10	3579		

POLARIS

Optimax 3.0L 250 HP-EX 2100/LE2100	2004-		1,1	PZFR5F-11	4363		
------------------------------------	-------	--	-----	-----------	------	--	--

PRO-LINE

Mercury Sportjet 90	-		1,0	BZ7HS-10	3579		
---------------------	---	--	-----	----------	------	--	--

C
Y
I

Stock-Nº



Stock-NºX

REDLINE

5.0L 302 cid		-		0,9	BPR6FS	2623	UR6IX	7348
5.8L 351 cid		-		0,9	BPR6FS	2623	UR6IX	7348
5.8L 351 cid HO		-		1,0	BPR6EFS	3623	TR6IX	3689
7.5L 460 cid		-		0,9	BPR6FS	2623	UR6IX	7348

REGAL

Mercury Sportjet 90 - 500cc		-		1,0	BZ7HS-10	3579		
Mercury Sportjet 120XR - 500cc		-		1,0	BZ7HS-10	3579		
Mercury Sportjet 175XR2 - 650cc		-		1,0	BZ7HS-10	3579		

RENKEN

Mercury Sportjet 120XR - 650cc		-		1,0	BZ7HS-10	3579		
--------------------------------	--	---	--	-----	----------	------	--	--

REVLEY

6 hp - Model R225		-		0,9	BP5S	3011	XR5IX	7355
6 hp - Model R300		-		0,9	BP5S	3011	XR5IX	7355
6 hp - Model R401		-		0,9	BP5S	3011	XR5IX	7355

REVMASER MARINE

Mercury Sportjet 90 - 650cc		-		1,0	BZ7HS-10	3579		
Mercury Sportjet 120XR - 650cc		-		1,0	BZ7HS-10	3579		

RICHLINE

Mercury Sportjet 90 - 700cc		-		1,0	BZ7HS-10	3579		
Mercury Sportjet 120XR - 700cc		-		1,0	BZ7HS-10	3579		

RINKER

Mercury Sportjet 120XR - 700cc		-		1,0	BZ7HS-10	3579		
--------------------------------	--	---	--	-----	----------	------	--	--

ROLLS-ROYCE

LM841		-		0,9	B5ES	6410		
V8 Engine	8	-		0,6	B5ES	6410		

SCARAB

Mer cruiser 4.3L		-		0,9	BPR4FS	1127	UR4IX	7401
------------------	--	---	--	-----	--------	------	-------	-------------

SEA RAY

40 hp - Mercury Sportjet 90		-		1,0	BZ7HS-10	3579		
43.7 hp - Mercury Sportjet 120XR		-		1,0	BZ7HS-10	3579		
45 hp - Mercury Sportjet 90		-		1,0	BZ7HS-10	3579		
45 hp - Mercury Sportjet 120XR		-		1,0	BZ7HS-10	3579		
60 hp - Mercury Sportjet 175XR2		-		1,0	BZ7HS-10	3579		

C
Y
I

Stock-Nr



Stock-NrX

SEA SKATE

25 hp - 2Si	-	0,9	BR8ES	5422	BR8EIX	5044
50 hp - 2Si	-	0,9	BR8ES	5422	BR8EIX	5044
50 hp - Brute	-	0,9	BR9ES	5722	BR9EIX	3981
70 hp - 2Si	-	0,9	BR8ES	5422	BR8EIX	5044

SEA SPIRITE

1.2 hp - Mercury Sportjet 90	-	1,0	BZ7HS-10	3579		
43.7 hp - Mercury Sportjet 120XR	-	1,0	BZ7HS-10	3579		

SEA-DOO

MERCURY

CHALLENGER 1800 - 210 hp - Mercury Engine M2 760cc	-	-	BUHW	2622		
CHALLENGER 1800 - 240 hp - Mercury Engine EFI 760cc	-	0,6	BR7HS	4122	BR7HIX	7067
CHALLENGER 2000 - 210 hp - Mercury Engine M2 800cc	-	-	BUHW	2622		
CHALLENGER 2000 - 240 hp - Mercury Engine EFI 800cc	-	0,6	BR7HS	4122	BR7HIX	7067
ISLANDIA - 210 hp - Mercury Engine M2 1000cc	-	-	BUHW	2622		
ISLANDIA - 240 hp - Mercury Engine EFI 1100cc	-	0,6	BR7HS	4122	BR7HIX	7067
SPEEDSTER SK - 210 hp - Mercury Engine M2 1000cc	-	-	BUHW	2622		
SPEEDSTER SK - 240 hp - Mercury Engine EFI 1100cc	-	0,6	BR7HS	4122	BR7HIX	7067
SPORTSTER 1800 - 210 hp - Mercury Engine M2 1200cc	-	-	BUHW	2622		
UTOPIA 185 - 200 hp - Mercury Engine M2 1200cc	-	1,0	BKR5E	7938	BKR5EIX	6341
UTOPIA 185 - 210 hp - Mercury Engine M2 1300cc	-	-	BUHW	2622		
UTOPIA 185 - 240 hp - Mercury Engine M2 EFI	-	1,0	BR7HS-10	1098		
UTOPIA 185 - 250 hp - Mercury Engine M2	-	1,0	BKR5E	7938	BKR5EIX	6341
UTOPIA 205 - 200 hp - Mercury Engine M2	-	1,0	BKR5E	7938	BKR5EIX	6341
UTOPIA 205 - 210 hp - Mercury Engine M2	-	-	BUHW	2622		
UTOPIA 205 - 240 hp - Mercury Engine M2 EFI	-	1,0	BR7HS-10	1098		
UTOPIA 205 - 250 hp - Mercury Engine M2	-	1,0	BKR5E	7938	BKR5EIX	6341
X-20 - 240 hp - Mercury Engine M2 EFI	-	1,0	BR7HS-10	1098		
X-20 - 250 hp - Mercury Engine M2	-	1,0	BKR5E	7938	BKR5EIX	6341

ROTAX

1998 CHALLENGER - 85 hp - Rotax Engine Twin 760cc	-	0,6	BR9ES	5722	BR9EIX	3981
1998 SPORTSTER - 85 hp - Rotax Engine 1200cc	-	0,6	BR9ES	5722	BR9EIX	3981
CHALLENGER - 85 hp - Rotax Engine Twin 800cc	-	1,0	BR9ES	5722	BR9EIX	3981
CHALLENGER - 101 hp - Rotax Engine Twin 700cc	-	0,6	BR9ES	5722	BR9EIX	3981
CHALLENGER 1800 - 85 hp - Rotax Engine Twin 760cc	-	0,6	BR9ES	5722	BR9EIX	3981
CHALLENGER 1800 - 110 hp - Rotax Engine Twin 760cc	-	0,6	BR9ES	5722	BR9EIX	3981
EXPLORER - 72 hp - Rotax Engine 1000cc	-	0,6	BR9ES	5722	BR9EIX	3981
SPEEDSTER - 110 hp - Rotax Engine Twin 1200cc	-	0,6	BR9ES	5722	BR9EIX	3981
SPEEDSTER SK - 85 hp - Rotax Engine Twin 1200cc	-	0,6	BR9ES	5722	BR9EIX	3981
SPORTSTER - 85 hp - Rotax Engine Twin 1200cc	-	0,6	BR9ES	5722	BR9EIX	3981
SPORTSTER 1800 - 85 hp - Rotax Engine Twin 1200cc	-	0,6	BR9ES	5722	BR9EIX	3981

SEA-PRO

40 hp - Mercury Sportjet 90	-	1,0	BZ7HS-10	3579		
40 hp - Mercury Sportjet 120XR	-	1,0	BZ7HS-10	3579		

C
Y
I

Stock-Nº



Stock-NºX

SEAMASTER

9.8 hp - 300		-		0,8	AR6FS	3323		
9.8 hp - 534		-		0,8	AR6FS	3323		

SEASWIRL

1.6 hp - OMC Turbojet 115		-		0,8	BZ7HS-10	3579		
---------------------------	--	---	--	-----	----------	------	--	--

SHOCKWAVE

2.5 hp - OMC Turbojet 115		-		0,8	BZ7HS-10	3579		
---------------------------	--	---	--	-----	----------	------	--	--

SIMPLEX

3 hp		-		0,8	G-27	3420		
15 hp - Marine Ford Conversion		-		0,8	B5HS	4210		

SOS EXPRESS

70 hp - Yamaha Engine		-		0,6	BR7HS	4122	BR7HIX	7067
-----------------------	--	---	--	-----	-------	------	--------	------

SPRINT

3.0 hp - 302 cid Redline		-		0,9	BPR5FS	2423	UR5IX	7177
3.0 hp - 350 cid Redline		-		1,0	BKR5E	7938	BKR5EIX	6341

STARBUCK BOATS

40 hp - 350 cid		-		0,9	BPR4FS	1127	UR4IX	7401
40 hp - 454 cid		-		0,9	BPR5FS	2423	UR5IX	7177

SUGAR SAND

4.0 hp - Mercury Sportjet 175XR2		-		1,0	BZ7HS-10	3579		
4.0 hp - Mercury Sportjet 95XR		-		1,0	BZ7HS-10	3579		
4.5 hp - Mercury Sportjet 120XR		-		1,0	BZ7HS-10	3579		
5.0 hp - Mercury Sportjet 90		-		1,0	BZ7HS-10	3579		
5.0 hp - Mercury Sportjet 95XR		-		1,0	BZ7HS-10	3579		
5.5 hp - Mercury Sportjet 120XR		-		1,0	BZ7HS-10	3579		
6.0 hp - Mercury Sportjet 175XR2		-		1,0	BZ7HS-10	3579		
7.0 hp - Mercury Sportjet 175XR2		-		1,0	BZ7HS-10	3579		

SUNBIRD

7.0 hp - OMC Turbojet 115		-		0,8	BZ7HS-10	3579		
---------------------------	--	---	--	-----	----------	------	--	--

SUNRAY

7.0 hp - Mercury Sportjet 90		-		1,0	BZ7HS-10	3579		
7.5 hp - Mercury Sportjet 120XR		-		1,0	BZ7HS-10	3579		

C
Y
I

Stock-Nº



Stock-NºX

TENDER JET

9.9 hp - Mercury Sportjet 95XR		-		1,0	BZ7HS-10	3579		
9.5 hp - Mercury Sportjet 175XR2		-		1,0	BZ7HS-10	3579		

TOYOTA

4.0 L 300 hp - Epic 21		-		1,1	IFR6T11	4589		
4.0 L 300 hp - Epic 22		-		1,1	IFR6T11	4589		
4.0 L 300 hp - S22		-		1,1	IFR6T11	4589		
4.0 L 300 hp - X22		-		1,1	IFR6T11	4589		
4,0L - Epic VT 300i	8	-		1,1	PFR5G-11	2647		

TRACKER

14 hp - Mercury Sportjet 90		-		1,0	BZ7HS-10	3579		
-----------------------------	--	---	--	-----	----------	------	--	--

TRULINE

15 hp - Mercury Sportjet 90		-		1,0	BZ7HS-10	3579		
Mercury Sportjet 120XR		-		1,0	BZ7HS-10	3579		

TURBO-MARINE

75 hp - Ford 104 cid Engs.		1973-		0,6	BPR6ES	7822	BPR6EIX	6637
75 hp - Ford 302 Escort	8	1973-		0,7	AR6FS	3323		
80 hp - Kohler K-399-2		1971-1973		0,5	AB-6	2910		

TWO RIVERS MARINE

Mercury Sportjet 90		-		1,0	BZ7HS-10	3579		
2.0 hp - Mercury Sportjet 120XR		-		1,0	BZ7HS-10	3579		

U. S. MARINE





3.0L - 181 cid		-		0,9	BR5ES	4722		
5.0L 225 hp - 305 cid		-		0,9	BR6FS	4323	BR6FIX	2318
5.7L 260 hp - 350 cid		-		0,9	BR6FS	4323	BR6FIX	2318
5.8L 240 hp - 351 cid		-		1,0	UR5	2771	UR5IX	7177
7.4L 330 hp - 454 cid		-		0,9	BR6FS	4323	BR6FIX	2318
7.5L 340 hp - 460 cid		-		1,0	UR5	2771	UR5IX	7177

ULTRANAUTICS

60 hp - 1660L Suzuki		-		0,6	BR7HS	4122	BR7HIX	7067
70 hp - 1670B Tohatsu		-		0,6	BR7HS	4122	BR7HIX	7067
60 hp - 1250 Suzuki		-		0,6	BR7HS	4122	BR7HIX	7067
60 hp - 1260 Suzuki		-		0,6	BR7HS	4122	BR7HIX	7067
70 hp - 1670 Tohatsu		-		0,6	BR7HS	4122	BR7HIX	7067

UNIVERSAL

Arrow		-		0,9	B6S	3510		
-------	--	---	--	-----	-----	------	--	--

	C Y I					Stock-N°		Stock-N°X
Atomic 1,2,3,4		-		0,9	B6S	3510		
Atomic Stevedore		-		0,9	B6S	3510		
Big King		-		0,9			WR5IX	7510
Bluefin		-		0,9	B6S	3510		
Bullit		-		0,9	B6S	3510		
Colt		-		0,9	B6S	3510		
DX Super Sabre		-		0,9	XR5	3332	XR5IX	7355
Elf		-		0,8	B6S	3510		
Knight		-		0,8	B6S	3510		
LEV 188 hp		-		0,7	B6S	3510		
LEVH 188 hp		-		0,7	B6S	3510		
Little King		-		0,7	B6S	3510		
Marlin		-		0,8	B6S	3510		
NKEV 277 hp		-		0,9			WR5IX	7510
Sabre 140 hp - 198 cid		-		0,9	XR5	3332	XR5IX	7355
Strato King		-		0,8	B6S	3510		
Super Sabre 155 hp - 225 cid		-		0,9	XR5	3332	XR5IX	7355
Tarpon		-		0,8	B6S	3510		
Z-Drive		-		0,9	B6S	3510		
VALMET (Vire)								
6.7 hp - Sailboat Auxiliary		-		0,6	BR6HS	3922	BR6HIX	3419
VOLVO-PENTA								
5.7L GXi		-		1,5	TR55	3951	TR55IX	7164
5.8L FL 4 bbl		-		0,9	UR4	6630	UR4IX	7401
5.8L FL/HS1		-		0,9	BPR4FS			
5.8L FSi EFI HO		-		0,9	BPR6EFS	3623	TR6IX	3689
5.8L Fsi/HS1		-		0,9	BPR6EFS			
7.4L Gi EFI		-		1,1	BPR6FS	2623	UR6IX	7348
7.4L GL		-		0,9	BR6FS			
7.4L GL 4 bbl		-		1,1	BR6FS	4323	BR6FIX	2318
7.4L GSi		-		0,9	BR6FS			
7.4L GSi EFI		-		1,1	BR6FS	4323	BR6FIX	2318
8.1L Gi		-		1,5	TR4	3754	TR4IX	7300
7.4L Gi EFI		-		0,9	BPR6FS			
8.1L Gsi		-		1,5	TR4	3754	TR4IX	7300
8.1L GXi		-		1,5	TR55	3951	TR55IX	7164
8.2L GSi EFI		-		1,1	BR6FS	4323	BR6FIX	2318
8.2L GXi		2002 - 2002		1,5	ITR4A15			
430		-		0,9	BR6FS			
500/501A		-		0,9	BR6FS			
531		-		0,9	BR6FS			
570A/571		-		0,9	BR6FS			
572		-		0,9	BR6FS			
740A		-		0,9	BR6FS			
Chevrolet 305 cid PZ-200 I/O		-		0,9	BR6FS	4323	BR6FIX	2318
SERIE B								
B16A		-		0,6	XR5	3332	XR5IX	7355
B16C		-		0,6	XR5	3332	XR5IX	7355
B18A		-		0,6	B6HS	4510	BR6HIX	3419





C
Y
I

Stock-Nr°



Stock-Nr°X

B18C	-	0,7	B6HS			
SERIE BB						
BB25	-	0,6	B6S	3510		
BB30B	-	0,6	B6HS	4510	BR6HIX	3419
BB30F	-	0,9	B5HS	4210		
BB70	-	0,6	B6S	3510		
BB70 (High speed use)	-	0,6	B8S	3810		
BB100	-	0,6	B6HS	4510	BR6HIX	3419
BB100A	-	0,6	B6HS	4510	BR6HIX	3419
BB115A	-	0,6	BP7HS	5111	BPR7HIX	5944
BB115B	-	0,6	BP7HS	5111	BPR7HIX	5944
BB115C	-	0,6	BP7HS	5111	BPR7HIX	5944
BB140	-	0,9	BP6ES	7811	BPR6EIX	6637
BB140A	-	0,6	BP8ES	2912	BPR8EIX	6684
BB145	-	0,9	BP6ES	7811	BPR6EIX	6637
BB145C	-	0,6	BP8ES	2912	BPR8EIX	6684
BB165A	-	0,6	BP7HS	5111	BPR7HIX	5944
BB170A	-	0,6	BP7HS	5111	BPR7HIX	5944
BB170B	-	0,6	BP7HS	5111	BPR7HIX	5944
BB170C	-	0,7	BP7HS			
BB225	-	0,9	BR6FS	4323	BR6FIX	2318
BB260	-	0,9	BR6FS	4323	BR6FIX	2318
BB260A	-	0,9	BR6FS			
BB260B	-	0,9	BR6FS			
BB260C	-	0,9	BR6FS			
SERIE C						
C2	-	0,6	AB-6	2910		
C5	-	0,6	AB-6	2910		
C10	-	0,6	AB-6	2910		
C23	-	0,6	AB-6	2910		
SERIE OCEAN						
4.3L OSi-XPD	-	0,9	TR5	2238	TR5IX	7397
5.0L OSi-XPD	-	0,9	TR5	2238	TR5IX	7397
5.7L OSi-XPD	-	0,9	TR5	2238	TR5IX	7397
5.7L OSXi-XPD	-	0,9	TR5	2238	TR5IX	7397
AQ						
145A, B	-	0,9	BP7ES	2412	BPR7EIX	4055
AQ60F	-	0,9	B5HS	4210		
AQ80	-	0,6	B6S	3510		
AQ90	-	0,6	B6HS	4510	BR6HIX	3419
AQ95	-	0,6	BP6HS	4511	BPR6HIX	4085
AQ95A	-	0,6	BP6HS	4511	BPR6HIX	4085
AQ100	-	0,6	BP6HS	4511	BPR6HIX	4085
AQ105A	-	0,6	BP7HS	5111	BPR7HIX	5944
AQ110	-	0,6	BP7HS	5111	BPR7HIX	5944
AQ115A	-	0,6	BP7HS	5111	BPR7HIX	5944
AQ115B	-	0,7	BP7HS			
AQ120	-	0,6	BP7HS	5111	BPR7HIX	5944
AQ120 (B21)	-	0,9	BP6ES	7811	BPR6EIX	6637
AQ120A	-	0,7	BP7HS			
AQ120B	-	0,7	BP7HS			
AQ125A	-	0,9	BP6ES	7811	BPR6EIX	6637
AQ125B	-	0,9	BP6ES	7811	BPR6EIX	6637

	C Y I					Stock-Nº	FRIBUM	Stock-NºX
AQ130		-		0,6	BP7HS	5111	BPR7HIX	5944
AQ130A		-		0,6	BP7HS	5111	BPR7HIX	5944
AQ130B		-		0,6	BP7HS	5111	BPR7HIX	5944
AQ130C		-		0,6	BP7HS	5111	BPR7HIX	5944
AQ130D		-		0,6	BP7HS	5111	BPR7HIX	5944
AQ131		-		0,9	BP7ES	2412	BPR7EIX	4055
AQ131A		-		0,9	BP7ES	2412	BPR7EIX	4055
AQ131B		-		0,9	BP7ES	2412	BPR7EIX	4055
AQ131C		-		0,9	BP7ES	2412	BPR7EIX	4055
AQ131D		-		0,9	BP7ES	2412	BPR7EIX	4055
AQ140		-		0,7	BP7ES			
AQ140A		-		0,9	BP7ES	2412	BPR7EIX	4055
AQ145		-		0,9	BP6ES	7811	BPR6EIX	6637
AQ145A		-		0,8	BP6ES			
AQ150		-		0,9	XR5	3332	XR5IX	7355
AQ150A		-		0,9	XR5	3332	XR5IX	7355
AQ150B		-		0,9	XR5	3332	XR5IX	7355
AQ151A		-		0,6	BP7ES	2412	BPR7EIX	4055
AQ151B		-		0,6	BP7ES	2412	BPR7EIX	4055
AQ151C		-		0,6	BP7ES	2412	BPR7EIX	4055
AQ155A		-		0,9	BP6S			
AQ165A		-		0,6	BP7HS	5111	BPR7HIX	5944
AQ170		-		0,6	BP7HS	5111	BPR7HIX	5944
AQ170A		-		0,6	BP7HS	5111	BPR7HIX	5944
AQ170B		-		0,6	BP7HS	5111	BPR7HIX	5944
AQ170C		-		0,6	BP7HS	5111	BPR7HIX	5944
AQ171A		-		0,9	BP6ES	7811	BPR6EIX	6637
AQ171A		-		0,7	BPR6ES			
AQ171C		-		0,9	BP6ES	7811	BPR6EIX	6637
AQ171C		-		0,7	BPR6ES			
AQ175		-		0,9	YR5	7052	YR5IX	7516
AQ175A		-		0,9	YR5	7052	YR5IX	7516
AQ180		-		0,6	XR5	3332	XR5IX	7355
AQ190		-		0,9	YR5	7052	YR5IX	7516
AQ190A		-		0,6	AR6FS	3323		
AQ200		-		0,6	UR5	2771	UR5IX	7177
AQ200A		-		0,6	UR5	2771	UR5IX	7177
AQ200B		-		0,6	UR5	2771	UR5IX	7177
AQ200C		-		0,6	UR5	2771	UR5IX	7177
AQ200D		-		0,6	UR5	2771	UR5IX	7177
AQ200F		-		0,6	UR5	2771	UR5IX	7177
AQ205A		-		0,9	YR5	7052	YR5IX	7516
AQ210A (-->N°177314)		-		0,6	B6S	3510		
AQ210A (N°177315-->)		-		0,6	UR6	7773	UR6IX	7348
AQ211		-		0,9	YR5	7052	YR5IX	7516
AQ211A		-		0,9	YR5	7052	YR5IX	7516
AQ211DP		-		0,9	YR5	7052	YR5IX	7516
AQ225		-		0,6	UR6	7773	UR6IX	7348
AQ225 305 c.i.		-		0,7	BPR6FS			
AQ225A		-		0,6	UR6	7773	UR6IX	7348
AQ225A 305 c.i.		-		0,7	BPR6FS			
AQ225B		-		0,6	UR6	7773	UR6IX	7348
AQ225B 305 c.i.		-		0,7	BPR6FS			

C
Y
I

Stock-N°



Stock-N°X

AQ225C	-	0,6	UR6	7773	UR6IX	7348
AQ225C 305 c.i.	-	0,7	BPR6FS			
AQ225D	-	0,6	UR6	7773	UR6IX	7348
AQ225D 305 c.i.	-	0,7	BPR6FS			
AQ225E	-	0,9	YR5	7052	YR5IX	7516
AQ225F	-	0,9	YR5	7052	YR5IX	7516
AQ230A	-	0,9	BPR6ES	7822	BPR6EIX	6637
AQ231	-	0,9	YR5	7052	YR5IX	7516
AQ231A	-	0,9	YR5	7052	YR5IX	7516
AQ231B	-	0,9	YR5	7052	YR5IX	7516
AQ231DP	-	0,9	YR5	7052	YR5IX	7516
AQ240A	-	0,6	UR6	7773	UR6IX	7348
AQ255B	-	0,6	UR6	7773	UR6IX	7348
AQ260	-	0,6	BR6FS	4323	BR6FIX	2318
AQ260A	-	0,6	BR6FS	4323	BR6FIX	2318
AQ260B	-	0,6	BR6FS	4323	BR6FIX	2318
AQ271	-	0,9	YR5	7052	YR5IX	7516
AQ271A	-	0,6	BR6FS	4323	BR6FIX	2318
AQ271B	-	0,6	BR6FS	4323	BR6FIX	2318
AQ271C	-	0,6	BR6FS	4323	BR6FIX	2318
AQ271D	-	0,6	BR6FS	4323	BR6FIX	2318
AQ271DP	-	0,9	YR5	7052	YR5IX	7516
AQ280A	-	0,6	UR6	7773	UR6IX	7348
AQ290A	-	0,6	BR6FS	4323	BR6FIX	2318
AQ290B	-	0,6	BR6FS	4323	BR6FIX	2318
AQ311A	-	0,6	BR6FS	4323	BR6FIX	2318
AQ311B	-	0,6	BR6FS	4323	BR6FIX	2318
AQ430	-	0,6	BR6FS	4323	BR6FIX	2318
AQ500A	-	0,9	BR6FS	4323	BR6FIX	2318
AQ501A	-	0,9	BR6FS	4323	BR6FIX	2318
AQ531	-	0,6	BR6FS	4323	BR6FIX	2318
AQ570A	-	0,9	BR6FS	4323	BR6FIX	2318
AQ571A	-	0,9	BR6FS	4323	BR6FIX	2318
AQ572	-	0,9	BR6FS	4323	BR6FIX	2318
AQ740A	-	0,9	BR6FS	4323	BR6FIX	2318

DPX

5.7L DPX 375	-	1,5	TR55	3951	TR55IX	7164
7.4L DPX 385 GSi EFI	-	1,1	BR6FS	4323	BR6FIX	2318
8.1L DPX 420	-	1,5	TR55	3951	TR55IX	7164
8.2L DPX 415 GSi EFI	-	1,1	BR6FS	4323	BR6FIX	2318

DUOPROP

4.3L Gi EFI	-	1,1	BPR6FS	2623	UR6IX	7348
4.3L Gi EFI	-	1,1	BPR6EFS	3623	TR6IX	3689
4.3L GIPNCA (Culot court)	-	0,9	BPR6FS			
4.3L GIPNCS (Culot long)	-	0,9	BPR6EFS			
4.3L GL 2 bbl	-	1,1	BPR6FS	2623	UR6IX	7348
4.3L GL 2 bbl	-	1,1	BPR6EFS	3623	TR6IX	3689
4.3L GS 4 bbl	-	1,1	BPR6FS	2623	UR6IX	7348
4.3L GS 4 bbl	-	1,1	BPR6EFS	3623	TR6IX	3689
5.0L Fi EFI	-	0,9	TR5	2238	TR5IX	7397
5.0L FL	-	0,9	BPR4FS			
5.0L FL 2 bbl	-	0,9	UR4	6630	UR4IX	7401
5.0L Gi Gen 1+	-	1,1	BPR6EFS	3623	TR6IX	3689

C
Y
I

Stock-Nº



Stock-NºX

5.0L GL Gen 1+	-	1,1	BPR6EFS	3623	TR6IX	3689
5.7L Gi	-	0,9	BPR6FS			
5.7L Gi EFI	-	1,1	BPR6FS	2623	UR6IX	7348
5.7L GL	-	0,9	BR6FS			
5.7L GL 2 bbl	-	1,1	BR6FS	4323	BR6FIX	2318
5.7L GLi	-	0,9	BPR6FS			
5.7L GLi EFI	-	1,1	BPR6FS	2623	UR6IX	7348
5.7L GS 4 bbl	-	1,1	BR6FS	4323	BR6FIX	2318
5.7L GS	-	0,9	BR6FS			
5.7L GS Gen 1+	-	1,1	BPR6EFS	3623	TR6IX	3689
5.7L GSi Gen 1+	-	1,1	BPR6EFS	3623	TR6IX	3689
5.7L GXi	-	1,5	TR55	3951	TR55IX	7164
5.8L FL	-	0,9	BPR4FS			
5.8L FL 4 bbl	-	0,9	UR4	6630	UR4IX	7401
5.8L FSi	-	0,9	BPR6EFS			
5.8L FSi EFI HO	-	0,9	BPR6EFS	3623	TR6IX	3689
7.4L Gi, GL	-	0,9	BR6FS			
7.4L Gi	-	1,1	BPR6FS	2623	UR6IX	7348
7.4L Gi L29	-	0,9	BPR6EFS	3623	TR6IX	3689
7.4L GL	-	0,9	BR6FS			
7.4L GL 4 bbl	-	1,1	BR6FS	4323	BR6FIX	2318
7.4L GSi	-	0,9	BR6FS			
7.4L GSi EFI	-	1,1	BR6FS	4323	BR6FIX	2318
8.2L GSi	-	0,9	BR6FS			
8.2L GSi EFI	-	1,1	BR6FS	4323	BR6FIX	2318
EC6	-	0,7	AB-6			
EC61	-	0,7	AB-6			
ED6	-	0,7	B6S			
EF4	-	0,7	B6S			
F1	-	0,7	AB-6			
F11	-	0,7	AB-6			
F12	-	0,7	AB-6			
F12A	-	0,7	AB-6			
K1	-	0,7	AB-6			
K2	-	0,7	AB-6			
K11	-	0,7	AB-6			
K21	-	0,7	AB-6			
K22	-	0,7	AB-6			
L2	-	0,7	AB-6			
L4	-	0,7	AB-6			
L6	-	0,7	AB-6			
L41	-	0,7	AB-6			
M1	-	0,7	AB-2			
M2	-	0,7	AB-2			
M4	-	0,7	AB-2			
MB2	-	0,6	D6HA	6512		
MB10	-	0,6	BP5HS	4111		
MB10	-	0,7	BP6HS			
MB10A	-	0,6	BP5HS	4111		
MB10A	-	0,7	BP6HS			
MB16A	-	0,7	B6S			
MB18F	-	0,9	B5HS	4210		
MB20A	-	0,6	BP6HS	4511	BPR6HIX	4085

C
Y
I

Stock-Nº

FRIDUM

Stock-NºX

MB20B		-		0,6	BP6HS	4511	BPR6HIX	4085
MB20C		-		0,7	B-4H			
MB36A		-		0,6	B6S	3510		
MB36B		-		0,6	B6S	3510		
MB50S		-		0,6	D6HA	6512		
MB100S		-		0,6	BP5HS	4111		
MB100S		-		0,7	BP6HS			
PZ-200 1/0		-		0,9	BR6FS			

PJX WATER JET

4.3L Gi EFI		-		1,1	BPR6EFS	3623	TR6IX	3689
4.3L GS 4 bbl		-		1,1	BPR6EFS	3623	TR6IX	3689

SX COBRA

3.0L GS 2 bbl		-		1,1	BPR6EFS	3623	TR6IX	3689
4.3L Gi EFI		-		1,1	BPR6FS	2623	UR6IX	7348
4.3L Gi EFI		-		1,1	BPR6EFS	3623	TR6IX	3689
4.3L GIPNCA (Culot court)		-		0,9	BPR6FS			
4.3L GIPNCS (Culot long)		-		0,9	BPR6EFS			
4.3L GL 2 bbl		-		1,1	BPR6EFS	3623	TR6IX	3689
4.3L GS 4 bbl		-		1,1	BPR6EFS	3623	TR6IX	3689
5.0L Fi		-		0,9	BPR6EFS			
5.0L Fi EFI		-		0,9	TR5	2238	TR5IX	7397
5.0L FL		-		0,9	BPR4FS			
5.0L FL 2 bbl		-		0,9	UR4	6630	UR4IX	7401
5.0L Gi Gen 1+		-		1,1	BPR6EFS	3623	TR6IX	3689
5.0L GL Gen 1+		-		1,1	BPR6EFS	3623	TR6IX	3689
5.7L Gi		-		0,9	BPR6FS			
5.7L Gi EFI		-		1,1	BPR6FS	2623	UR6IX	7348
5.7L GL		-		0,9	BR6FS			
5.7L GL 2 bbl		-		1,1	BR6FS	4323	BR6FIX	2318
5.7 GLi		-		0,9	BPR6FS			
5.7L GLi EFI		-		1,1	BPR6FS	2623	UR6IX	7348
5.7L GS		-		0,9	BR6FS			
5.7L GS 4 bbl		-		1,1	BR6FS	4323	BR6FIX	2318
5.7L GS Gen 1+		-		1,1	BPR6EFS	3623	TR6IX	3689
5.7L GSi Gen 1+		-		1,1	BPR6EFS	3623	TR6IX	3689
5.7L GXi		-		1,5	TR55	3951	TR55IX	7164
5.8L Fi		-		0,9	BPR6EFS			
5.8L FL		-		0,9	BPR4FS			
5.8L FL 4 bbl		-		0,9	UR4	6630	UR4IX	7401
5.8L FSi		-		0,9	BPR6EFS			
5.8L FSi EFI HO		-		0,9	BPR6EFS	3623	TR6IX	3689
7.4L Gi EFI		-		1,1	BPR6FS	2623	UR6IX	7348
7.4L Gi L29		-		0,9	BPR6EFS	3623	TR6IX	3689
7.4L Gi		-		0,9	BPR6FS			
7.4L GL		-		0,9	BPR6FS			
7.4L GL 4 bbl		-		1,1	BR6FS	4323	BR6FIX	2318

VOLKSWAGEN

SDI 45-4	4	2001 -		12V	Y-732J	5605		
SDI 50-4	4	-		12V	Y-732J	5605		
SDI 55-5	5	2001 -		12V	Y-732J	5605		
SDI 60-4	4	2001 -		12V	Y-732J	5605		

C
Y
I

Stock-Nº



Stock-NºX

SDI 75-5	5	2001-		12V	Y-732J	5605		
TDI 100-5	5	2001-		12V	Y-732J	5605		
TDI 115-4	4	2001-		12V	Y-732J	5605		
TDI 120-5	5	-		12V	Y-732J	5605		
TDI 150-5	5	2001-		12V	Y-732J	5605		
TDI 165-5	5	-		12V	Y-732J	5605		
TDI 225-6	6	-		12V	Y-732J	5605		

VOYAGER MARINE

4 hp - Mercury Sportjet 120XR		-		1,0	BZ7HS-10	3579		
4 hp - Mercury Sportjet 175XR2		-		1,0	BZ7HS-10	3579		

WAUKESHA

155 hp - 302/2b		-		0,9	AR6FS	3323		
155 hp - WLA		-		0,9	AR6FS	3323		
155 hp - WRA		-		0,9	AR6FS	3323		
165 hp - 302/2a		-		0,9	AR6FS	3323		
165 hp - WLE		-		0,9	AR6FS	3323		
165 hp - WRE		-		0,9	AR6FS	3323		
185 hp - 302/2		-		0,9	AR6FS	3323		
185 hp - WLB		-		0,9	AR6FS	3323		
185 hp - WRB		-		0,9	AR6FS	3323		
215 hp - 302/4		-		0,9	AR6FS	3323		
215 hp - WLC		-		0,9	AR6FS	3323		
215 hp - WRC		-		0,9	AR6FS	3323		
255 hp - 351/4		-		0,9	AR6FS	3323		
255 hp - WLD		-		0,9	AR6FS	3323		
255 hp - WRD		-		0,9	AR6FS	3323		
350 hp - 460/4		-		0,9	BPR5FS	2423	UR5IX	7177
350 hp - WLF		-		0,9	BPR5FS	2423	UR5IX	7177
350 hp - WRF		-		0,9	BPR5FS	2423	UR5IX	7177

WAVECUTTER

4 hp - Mercury Sportjet 95XR		-		1,0	BZ7HS-10	3579		
4 hp - Mercury Sportjet 120XR		-		1,0	BZ7HS-10	3579		

WETT VET

4 hp - Mercury Sportjet 120XR		-		1,0	BZ7HS-10	3579		
-------------------------------	--	---	--	-----	----------	------	--	--

WHALER

4.5 hp - OMC Turbojet 90		-		0,8	BZ7HS-10	3579		
5 hp - OMC Turbojet 115		-		0,8	BZ7HS-10	3579		

WILSON

5 hp - Mercury Sportjet 120XR		-		1,0	BZ7HS-10	3579		
-------------------------------	--	---	--	-----	----------	------	--	--

C
Y
I

Stock-Nº



Stock-NºX

WISCONSIN

ABM	-		0,6	AB-6	2910		
AEM	-		0,6	AB-6	2910		
AKM	-		0,6	AB-6	2910		
TFM	-		0,6	AB-6	2910		
VH4M	-		0,6	AB-6	2910		

YAMAHA

110	1963 - 1966		0,8	B6ES	7310		
-----	-------------	--	-----	------	------	--	--

1000 CC

AR230	2004 - 2006		0,8	CR9EB	6955	CR9EIX	3521
SR230	2003 - 2005		0,8	CR9EB	6955	CR9EIX	3521
SX230	2003 - 2006		0,8	CR9EB	6955	CR9EIX	3521

1100 CC

212S	2008 - 2010		0,8	CR9EB	6955	CR9EIX	3521
212X	2008 - 2010		0,8	CR9EB	6955	CR9EIX	3521
232 Limited	2008 - 2009		0,8	CR9EB	6955	CR9EIX	3521
AR210	2003 - 2010		0,8	CR9EB	6955	CR9EIX	3521
AR230	2003 - 2005		0,8	CR9EB	6955	CR9EIX	3521
AR230 High Output	2005 - 2009		0,8	CR9EB	6955	CR9EIX	3521
SR210	2007 -		0,8	CR9EB	6955	CR9EIX	3521
SR230	2003 - 2005		0,8	CR9EB	6955	CR9EIX	3521
SR230 High Output	2007 -		0,8	CR9EB	6955	CR9EIX	3521
SX210	2007 -		0,8	CR9EB	6955	CR9EIX	3521
SX230	2003 - 2005		0,8	CR9EB	6955	CR9EIX	3521
SX230 High Output	2005 - 2009		0,8	CR9EB	6955	CR9EIX	3521

1200 CC

AR210	2003 - 2005		0,6	BR8HS	4322	BR8HIX	7001
Exciter 270	1998 - 1999		0,6	BR8HS	4322	BR8HIX	7001
LX210	2003 - 2005		0,6	BR8HS	4322	BR8HIX	7001

STERN DRIVE

3.0l L4 EST	4	1990 - 1991		0,9	BR6FS	4323	BR6FIX	2318
4.3L V6	6	1989 - 1992		0,9	BR6FS	4323	BR6FIX	2318
5.0L V8	8	1989 - 1992		0,9	BR6FS	4323	BR6FIX	2318
5.8L V8	8	1989 - 1992		0,9	BR6FS			
Exciter 135 1200cc		1998 - 1999		0,6	BR8HS	4322	BR8HIX	7001
Exciter 220 1100cc		1996 - 1998		0,6	BR8HS	4322	BR8HIX	7001
Exciter 227 1200cc		1998 - 1999		0,6	BR8HS	4322	BR8HIX	7001
LS2000 1200cc		1999 - 2002		0,6	BR8HS	4322	BR8HIX	7001
LX2000 1200cc		2002 - 2002		0,6	BR8HS	4322	BR8HIX	7001
XR1800 1200cc		2000 - 2001		1,1	BR8ES-11	7986		

YANMAR

13hp - SD25 /SD20 (2YM15 Engine)	-			Y-546J	95275		
21 hp - SD25 /SD20 (3YM20C)	-			Y-546J	95275		
29hp - SD25 /SD20 (3YM30AEC)	-			Y-546J	95275		

ZODIAC

50 hp - Yamaha Twin	-		0,6	BR7HS	4122	BR7HIX	7067
---------------------	---	--	-----	-------	------	--------	-------------



C
Y
I



Stock-Nº

FRIBUM

Stock-NºX

OMC Turbojet 115

-

1,0

BZ7HS-10

3579

OMC Turbojet 115

-

1,0

BZ7HS-10

3579

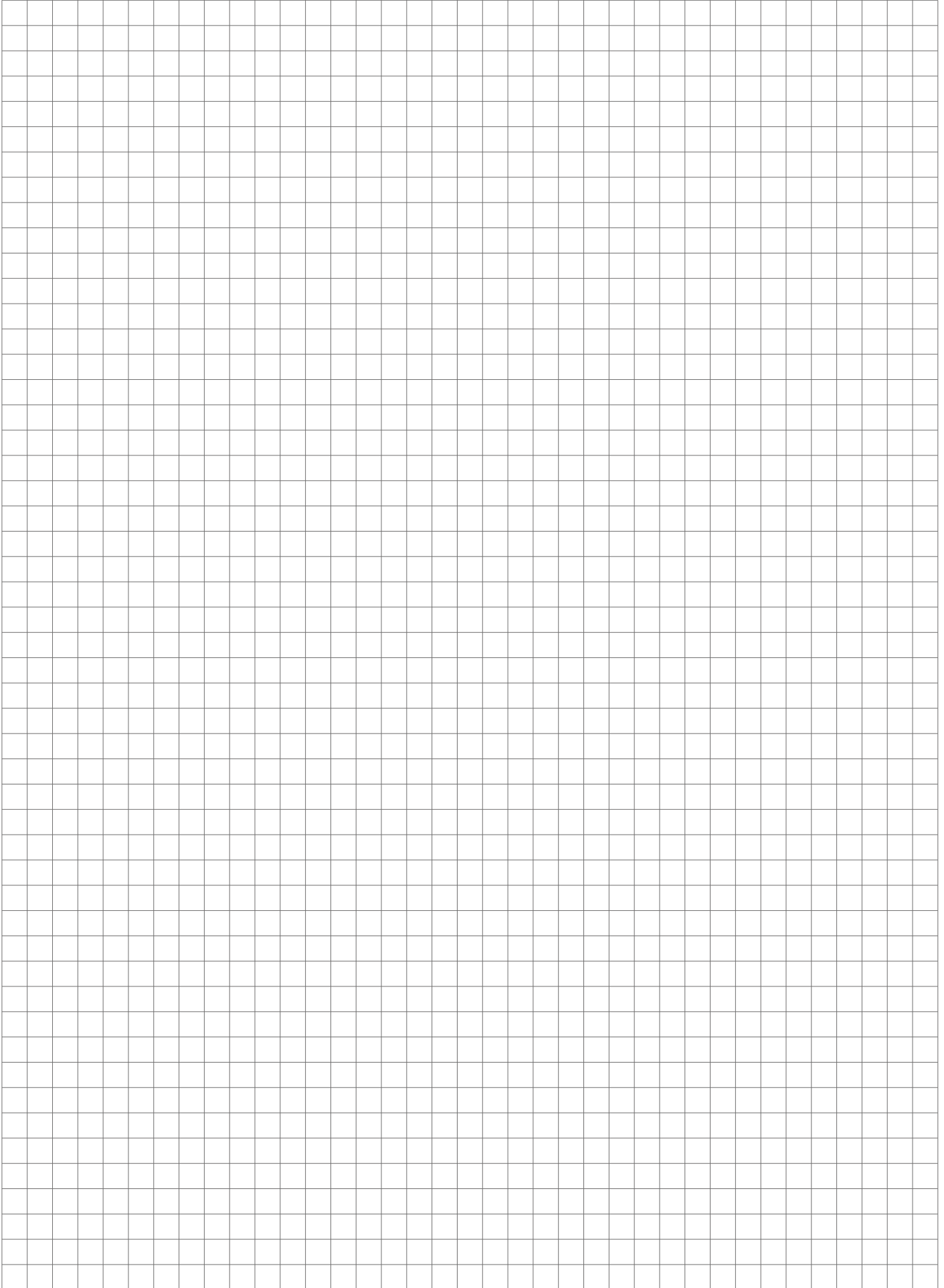



IGNITION
PARTS





HP c c m C y i



Stock-Nr

FRIBUM

Stock-NrX

AQUA-JET (Jet Bike)

Solution SX1	40	432	-		0,8	B7ES	1111	BR7EIX	6664
WX-1 1250 R		1250	2001-2003		0,6	BR8ES	5422	BR8EIX	5044

AQUASCOOTER

moteur ILO		48	-		0,8	B5HS	4210		
------------	--	----	---	--	-----	------	------	--	--

ARCTO / TIGERSHARK

Daytona		640	2	1993-1995		0,7	BR9ES	5722	BR9EIX	3981
Tigershark		640	2	1993-1993		0,7	BR9ES	5722	BR9EIX	3981
Barracuda		640	2	1994-1995		0,7	BR9ES	5722	BR9EIX	3981
Monte Carlo		640	2	1994-1996		0,7	BR9ES	5722	BR9EIX	3981
Montego		640	2	1994-1996		0,7	BR9ES	5722	BR9EIX	3981
Deluxe		640	2	1994-1996		0,7	BR9ES	5722	BR9EIX	3981
Monte Carlo		640	2	1997-1997		0,7	BR9EYA	7548	BR9EIX	3981
Montego		640	2	1997-1997		0,7	BR9EYA	7548	BR9EIX	3981
Deluxe		640	2	1997-1997		0,7	BR9EYA	7548	BR9EIX	3981
TS 640		640	2	1998-1999		0,7	BR9EYA	7548	BR9EIX	3981
TS-L640		640	2	1998-1999		0,7	BR9EYA	7548	BR9EIX	3981
Daytona 770		770	2	1996-1996		0,7	BR9ES	5722	BR9EIX	3981
Monte Carlo 770 Blue		770	2	1996-1996		0,7	BR9ES	5722	BR9EIX	3981
Monte Carlo 770 Red		770	2	1996-1996		0,7	BR9ES	5722	BR9EIX	3981
Daytona 770		770	2	1997-1997		0,7	BR9EYA	7548	BR9EIX	3981
Monte Carlo 770		770	2	1997-1997		0,7	BR9EYA	7548	BR9EIX	3981
TS-770		770	2	1998-1999		0,7	BR9EYA	7548	BR9EIX	3981
TS-L770		770	2	1998-1999		0,7	BR9EYA	7548	BR9EIX	3981
TS-R770		770	2	1998-1999		0,7	BR9EYA	7548	BR9EIX	3981
Tigershark		900	3	1995-1995		0,7	BR9ES	5722	BR9EIX	3981
Monte Carlo 900		900	3	1996-		0,7	BR9ES	5722	BR9EIX	3981
TS-900L		900	3	1999-1999		0,7	BR9ES	5722	BR9EIX	3981
Monte Carlo 1000		1000	3	1997-1997		0,7	BR9EYA	7548	BR9EIX	3981
Daytona 1000		1000	3	1997-1997		0,8	BR9EYA	7548	BR9EIX	3981
TS-L1000		1000	3	1998-1998		0,7	BR9EYA	7548	BR9EIX	3981
TS-R1000		1000	3	1998-1998		0,7	BR9EYA	7548	BR9EIX	3981
TS-1100R		1100	3	1999-1999		0,7	BR9EYA	7548	BR9EIX	3981
TS-1100Li		1100	3	1999-1999		0,7	PZFR6H	7696		

DOLPHIN







Mark 7 Auxiliary	12			-		0,6	B6ES	7310		
------------------	----	--	--	---	--	-----	------	------	--	--

FUN BOATS

Pump'r	60			-		1,0	B7HS	5110	BR7HIX	7067
--------	----	--	--	---	--	-----	------	------	--------	------

HONDA

Aqua Trax R-12	ARX1200N2 A	125	1200	4	2004-2006		0,9	IMR9D-9H	6544	
Aqua Trax F-12	ARX1200N3 A	125	1200	4	2002-2007		0,9	IMR9D-9H	6544	
Aqua Trax R-12X	ARX1200T2 A	165	1200	4	2003-2007		0,9	IMR9D-9H	6544	

		HP	c m	C y l					Stock-Nº		Stock-NºX
Aqua Trax F-12X	ARX1200T3 A	165	1200	4	2002-2007		0,9	IMR9D-9H	6544		
Aqua Trax F-12X GPS	ARX1200T3D A	165	1200	4	2005-2007		0,9	IMR9D-9H	6544		
Aqua Trax F-15	ARX1500N3 A		1500	4	2009-2009		0,9	IMR9D-9H	6544		
Aqua Trax F-15X	ARX1500T3 A	200	1500	4	2008-2009		0,9	IMR9D-9H	6544		
Aqua Trax F-15X GPS	ARX1500T3D 2A	200	1500	4	2008-2009		0,9	IMR9D-9H	6544		

HOVERCRAFT

EC25PS			250		-		0,7	BR9ES	3194	BR9EIX	3981
EC25-PS			440		-		0,8	BR9ES	3194	BR9EIX	3981
EC44-2PM			440		-		0,8	BR9ES	3194	BR9EIX	3981
EC44-PM			440		-		0,8	BR9ES	3194	BR9EIX	3981
EC50-2PM			440		-		0,8	BR9ES	3194	BR9EIX	3981
EC50PM			500		-		0,7	BR9ES	3194	BR9EIX	3981

JET BREEZE

Hurricane		50			-		0,8	B9ES	2611	BR9EIX	3981
-----------	--	----	--	--	---	--	-----	------	------	--------	------

KAWASAKI

440	JS440-A17		440	2	1993-1994		0,8	BR7ES	5122	BR7EIX	6664
550 SX	JS550-C3		550	2	1993-1993		0,8	BR8ES	5422	BR8EIX	5044
550 SX	JS550-C4		550	2	1994-1994		0,8	BR8ES	5422	BR8EIX	5044
X-2	JF650-A3		650	2	1988-1988		0,8	BR7ES	5122	BR7EIX	6664
X-2	JF650-A4		650	2	1989-1989		0,8	BR7ES	5122	BR7EIX	6664
X-2	JF650-A5		650	2	1990-1990		0,8	BR7ES	5122	BR7EIX	6664
X-2	JF650-A6		650	2	1991-1991		0,8	BR7ES	5122	BR7EIX	6664
X-2	JF650-A7		650	2	1992-1992		0,8	BR7ES	5122	BR7EIX	6664
X-2	JF650-A8		650	2	1993-1993		0,8	BR7ES	5122	BR7EIX	6664
X-2	JF650-A9		650	2	1994-1994		0,8	BR7ES	5122	BR7EIX	6664
X-2	JF650-A10		650	2	1995-1995		0,8	BR7ES	5122	BR7EIX	6664
650 SX	JS650-B3		650	2	1993-1994		0,8	BR7ES	5122	BR7EIX	6664
TS	JF650-B3		650	2	1991-1996		0,8	BR7ES	5122	BR7EIX	6664
TS	JF650-B4		650	2	1991-1996		0,8	BR7ES	5122	BR7EIX	6664
TS	JF650-B5		650	2	1991-1996		0,8	BR7ES	5122	BR7EIX	6664
TS	JF650-B6		650	2	1991-1996		0,8	BR7ES	5122	BR7EIX	6664
TS	JF650-B7		650	2	1991-1996		0,8	BR7ES	5122	BR7EIX	6664
TS	JF650-B8		650	2	1991-1996		0,8	BR7ES	5122	BR7EIX	6664
SC	JL650-A1		650	2	1991-1991		0,8	BR7ES	5122	BR7EIX	6664
SC	JL650-A2		650	2	1992-1992		0,8	BR7ES	5122	BR7EIX	6664
SC	JL650-A3		650	2	1993-1993		0,8	BR7ES	5122	BR7EIX	6664
SC	JL650-A4		650	2	1994-1994		0,8	BR7ES	5122	BR7EIX	6664
SC	JL650-A5		650	2	1995-1995		0,8	BR7ES	5122	BR7EIX	6664
X-4	JH750-A1		750	2	1992-1992		0,8	BR8ES	5422	BR8EIX	5044
X-4	JH750-A2		750	2	1993-1993		0,8	BR8ES	5422	BR8EIX	5044
X-4	JH750-A3		750	2	1994-1994		0,8	BR8ES	5422	BR8EIX	5044
X-4	JH750-A4		750	2	1995-1995		0,8	BR8ES	5422	BR8EIX	5044
X-4	JH750-E1		750	2	1996-1996		0,8	BR8ES	5422	BR8EIX	5044
Super Sport XI	JH750-B1		750	2	1993-1993		0,8	BR8ES	5422	BR8EIX	5044
Super Sport XI	JH750-B2		750	2	1994-1994		0,8	BR8ES	5422	BR8EIX	5044
Super Sport XI	JH750-B3		750	2	1995-1995		0,8	BR8ES	5422	BR8EIX	5044
750 ZXi	JH750-C1		750	2	1995-1995		0,8	BR8ES	5422	BR8EIX	5044



HP







c
c
mC
y
l

Stock-Nr



Stock-NrX

750 ZXi	JH750-C2	750	2	1996-1996	0,8	BR8ES	5422	BR8EIX	5044
750 ZXi	JH750-C3	750	2	1997-1997	0,8	BR8ES	5422	BR8EIX	5044
SS	JH750-A1	750	2	1992-1992	0,8	BR8ES	5422	BR8EIX	5044
SS	JH750-A2	750	2	1993-1993	0,8	BR8ES	5422	BR8EIX	5044
SS	JH750-A3	750	2	1994-1994	0,8	BR8ES	5422	BR8EIX	5044
SS	JH750-A4	750	2	1995-1995	0,8	BR8ES	5422	BR8EIX	5044
SS	JH750-E1	750	2	1996-1996	0,8	BR8ES	5422	BR8EIX	5044
SS	JH750-E2	750	2	1997-1997	0,8	BR8ES	5422	BR8EIX	5044
Super Sport XI	JH750-F1	750	2	1996-1996	0,8	BR8ES	5422	BR8EIX	5044
Super Sport XI	JH750-F2	750	2	1997-1997	0,8	BR8ES	5422	BR8EIX	5044
Xi Sport	JH750-G1	750	2	1998-1998	0,8	BR8ES	5422	BR8EIX	5044
Xi Sport	JH750-G2	750	2	1999-1999	0,8	BR8ES	5422	BR8EIX	5044
750 SX	JS750-A1	750	2	1992-1992	0,8	BR8ES	5422	BR8EIX	5044
750 SX	JS750-A2	750	2	1993-1993	0,8	BR8ES	5422	BR8EIX	5044
750 SX	JS750-A3	750	2	1994-1994	0,8	BR8ES	5422	BR8EIX	5044
750 SX	JS750-A4	750	2	1995-1995	0,8	BR8ES	5422	BR8EIX	5044
750 Sxi	JS750-B1	750	2	1995-1995	0,8	BR8ES	5422	BR8EIX	5044
750 Sxi	JS750-B2	750	2	1996-1996	0,8	BR8ES	5422	BR8EIX	5044
750 Sxi	JS750-B3	750	2	1997-1997	0,8	BR8ES	5422	BR8EIX	5044
750 SXi PRO	JS750-C1	750	2	1998-1998	0,8	BR8ES	5422	BR8EIX	5044
750 SXi PRO	JS750-C2	750	2	1999-1999	0,8	BR8ES	5422	BR8EIX	5044
750 SXi PRO	JS750-C3	750	2	2000-2000	0,8	BR8ES	5422	BR8EIX	5044
750 SXi PRO	JS750-C4	750	2	2001-2001	0,8	BR8ES	5422	BR8EIX	5044
750 SXi PRO	JS750-C5	750	2	2002-2002	0,8	BR8ES	5422	BR8EIX	5044
ST	JT750-A1	750	2	1994-1994	0,8	BR8ES	5422	BR8EIX	5044
ST	JT750-A2	750	2	1995-1995	0,8	BR8ES	5422	BR8EIX	5044
STS	JT750-B1	750	2	1995-1995	0,8	BR8ES	5422	BR8EIX	5044
STS	JT750-B2	750	2	1996-1996	0,8	BR8ES	5422	BR8EIX	5044
STS	JT750-B3	750	2	1997-1997	0,8	BR8ES	5422	BR8EIX	5044
STS	JT750-C1	750	2	1998-1998	0,8	BR8ES	5422	BR8EIX	5044
800 SX-R	JS800-A1	800	2	2003-2003	0,8	BR8ES	5422	BR8EIX	5044
800 SX-R	JS800-A2	800	2	2004-2004	0,8	BR8ES	5422	BR8EIX	5044
800 SX-R	JS800-A3	800	2	2005-2005	0,8	BR8ES	5422	BR8EIX	5044
800 SX-R	JS800A6F	800	2	2006-2006	0,8	BR8ES	5422	BR8EIX	5044
800 SX-R	JS800A7F	800	2	2007-2007	0,8	BR8ES	5422	BR8EIX	5044
800 SX-R	JS800A8F	800	2	2008-2008	0,8	BR8ES	5422	BR8EIX	5044
800 SX-R	JS800A9F	800	2	2009-2009	0,8	BR8ES	5422	BR8EIX	5044
800 SX-R	JS800AAF	800	2	2010-2010	0,8	BR8ES	5422	BR8EIX	5044
800 SX-R	JS800ABF	800	2	2011-2011	0,8	BR8ES	5422	BR8EIX	5044
900 ZXi	JH900-A1	900	3	1995-1995	0,8	BR9ES	5722	BR9EIX	3981
900 ZXi	JH900-A2	900	3	1996-1996	0,8	BR9ES	5722	BR9EIX	3981
900 ZXi	JH900-A3	900	3	1997-1997	0,8	BR9ES	5722	BR9EIX	3981
900 STX	JT900-A1	900	3	1997-1997	0,8	BR9ES	5722	BR9EIX	3981
900 STX	JT900-A2	900	3	1998-1998	0,8	BR9ES	5722	BR9EIX	3981
900 STX	JT900-B1	900	3	1999-1999	0,8	BR9ES	5722	BR9EIX	3981
900 STX	JT900-B2	900	3	2000-2000	0,8	BR9ES	5722	BR9EIX	3981
900 STS	JT900-B3	900	3	2001-2001	0,8	BR9ES	5722	BR9EIX	3981
900 STS	JT900-B4	900	3	2002-2002	0,8	BR9ES	5722	BR9EIX	3981
900 STX	JT900-C1	900	3	2001-2001	0,8	BR9ES	5722	BR9EIX	3981
900 STX	JT900-C2	900	3	2002-2002	0,8	BR9ES	5722	BR9EIX	3981
900 STX	JT900-D1	900	3	2003-2003	0,8	BR9ES	5722	BR9EIX	3981
900 STX	JT900-E1	900	3	2004-2004	0,8	BR9ES	5722	BR9EIX	3981
900 STX	JT900-E2	900	3	2005-2005	0,8	BR9ES	5722	BR9EIX	3981

		HP	c c m	C y l					Stock-Nº		Stock-NºX
900 STX	JT-900E6F		900	3	2006-2006		0,8	BR9ES	5722	BR9EIX	3981
Ultra 130	JH1100-B1		1100	3	2001-2001		0,8	PZFR7G-G	4253		
Ultra 130	JH1100-B2		1100	3	2002-2002		0,8	PZFR7G-G	4253		
Ultra 130	JH1100-B3		1100	3	2003-2003		0,8	PZFR7G-G	4253		
Ultra 130	JH1100-B4		1100	3	2004-2004		0,8	PZFR7G-G	4253		
1100 Zxi	JH1100-A1		1100	3	1996-2003		0,8	BR9ES	5722	BR9EIX	3981
1100 Zxi	JH1100-A2		1100	3	1996-2003		0,8	BR9ES	5722	BR9EIX	3981
1100 Zxi	JH1100-A3		1100	3	1996-2003		0,8	BR9ES	5722	BR9EIX	3981
1100 Zxi	JH1100-A4		1100	3	1996-2003		0,8	BR9ES	5722	BR9EIX	3981
1100 Zxi	JH1100-A5		1100	3	1996-2003		0,8	BR9ES	5722	BR9EIX	3981
1100 Zxi	JH1100-A6		1100	3	1996-2003		0,8	BR9ES	5722	BR9EIX	3981
1100 Zxi	JH1100-A7		1100	3	1996-2003		0,8	BR9ES	5722	BR9EIX	3981
1100 Zxi	JH1100-A8		1100	3	1996-2003		0,8	BR9ES	5722	BR9EIX	3981
1100 STX	JT1100-A1		1100	3	1997-1997		0,8	BR9ES	5722	BR9EIX	3981
1100 STX	JT1100-B1		1100	3	1998-1998		0,8	BR9ES	5722	BR9EIX	3981
1100 STX	JT1100-B2		1100	3	1999-1999		0,8	BR9ES	5722	BR9EIX	3981
1100 STX	JT1100-E1		1100	3	2000-2000		0,8	BR9ES	5722	BR9EIX	3981
1100 STX	JT1100-E2		1100	3	2001-2001		0,8	BR9ES	5722	BR9EIX	3981
1100 STX D.I.	JT1100-C1		1100	3	2000-2000		0,8	PZFR7G-G	4253		
1100 STX D.I.	JT1100-F1		1100	3	2001-2001		0,8	PZFR7G-G	4253		
1100 STX D.I.	JT1100-F2		1100	3	2002-2002		0,8	PZFR7G-G	4253		
1100 STX D.I.	JT1100-G1		1100	3	2003-2003		0,8	PZFR7G-G	4253		
Ultra 150	JH1200-A1		1200	3	1999-1999		0,6	R6918C-9	5196		
Ultra 150	JH1200-A2		1200	3	2000-2000		0,6	R6918C-9	5196		
Ultra 150	JH1200-A3		1200	3	2001-2001		0,6	R6918C-9	5196		
Ultra 150	JH1200-A4		1200	3	2002-2002		0,6	R6918C-9	5196		
Ultra 150	JH1200-B1		1200	3	2003-2003		0,8	BR9ES	5722	BR9EIX	3981
Ultra 150	JH1200-B2		1200	3	2004-2004		0,8	BR9ES	5722	BR9EIX	3981
Ultra 150	JH1200-B3		1200	3	2005-2005		0,8	BR9ES	5722	BR9EIX	3981
1200 STX-R	JT1200-A1		1200	3	2002-2002		0,8	BR9ES	5722	BR9EIX	3981
1200 STX-R	JT1200-A2		1200	3	2003-2003		0,8	BR9ES	5722	BR9EIX	3981
1200 STX-R	JT1200-C1		1200	3	2004-2004		0,8	BR9ES	5722	BR9EIX	3981
1200 STX-R	JT1200-C2		1200	3	2005-2005		0,8	BR9ES	5722	BR9EIX	3981
STX-12F	JT1200-B1		1200	4	2003-2004		0,6	CR9EK	4548	CR9EIX	3521
STX-12F	JT1200-B2		1200	4	2003-2004		0,6	CR9EK	4548	CR9EIX	3521
STX-12F	JT1200-D1		1200	4	2005-2007		0,6	CR9EK	4548	CR9EIX	3521
STX-12F	JT1200D6F		1200	4	2005-2007		0,6	CR9EK	4548	CR9EIX	3521
STX-12F	JT1200D7F		1200	4	2005-2007		0,6	CR9EK	4548	CR9EIX	3521
STX-15F	JT1500-A1		1500	4	2004-2004		0,8	CR9EK	4548	CR9EIX	3521
STX-15F	JT1500-A2		1500	4	2005-2005		0,8	CR9EK	4548	CR9EIX	3521
STX-15F	JT1500A6F		1500	4	2006-2006		0,8	CR9EK	4548	CR9EIX	3521
STX-15F	JT1500A7F		1500	4	2007-2007		0,8	CR9EK	4548	CR9EIX	3521
STX-15F	JT1500A8F		1500	4	2008-2008		0,8	CR9EK	4548	CR9EIX	3521
STX-15F	JT1500A9F		1500	4	2009-2009		0,8	CR9EK	4548	CR9EIX	3521
STX-15F	JT1500AAF		1500	4	2010-2010		0,8	CR9EK	4548	CR9EIX	3521
STX-15F	JT1500ABF		1500	4	2011-2011		0,8	CR9EK	4548	CR9EIX	3521
STX-15F	JT1500ACF		1500	4	2012-2012		0,8	CR9EK	4548	CR9EIX	3521
STX-15F	JT1500ADF		1500	4	2013-2013		0,8	CR9EK	4548	CR9EIX	3521
STX-15F	JT1500AEF		1500	4	2014-2014		0,8	CR9EK	4548	CR9EIX	3521
STX-15F	JT1500AFF	152	1500	4	2015-2015		0,8	CR9EK	4548	CR9EIX	3521
STX-15F	JT1500AGF	152	1500	4	2016-2016		0,8	CR9EKB	2305	CR9EIX	3521
STX-15F	JT1500AHF	152	1500	4	2017-2017		0,8	CR9EKB	2305	CR9EIX	3521
STX-15F	JT1500AJF	152	1500	4	2018-2018		0,8	CR9EKB	2305	CR9EIX	3521



HP

c
c
mC
Y
I

Stock-No



Stock-No X

SX-R	JT1500AHF	152	1500	4	2017-2017		0,8	CR9EKB	2305	CR9EIX	3521
SX-R	JT1500AJF	152	1500	4	2018-2018		0,8	CR9EKB	2305	CR9EIX	3521
Ultra 250X	JT1500B7F		1500	4	2007-2007		0,7	PMR9B	4717		
Ultra 250X	JT1500B8F		1500	4	2008-2008		0,7	PMR9B	4717		
STX	JT1500D9F		1500	4	2009-2009		0,8	CR9EK	4548	CR9EIX	3521
STX	JT1500DAF		1500	4	2010-2010		0,8	CR9EK	4548	CR9EIX	3521
Ultra 260X	JT1500E9F		1500	4	2009-2009		0,7	PMR9B	4717		
Ultra 260X	JT1500EAF		1500	4	2010-2010		0,7	PMR9B	4717		
Ultra 260LX	JT1500F9F		1500	4	2009-2009		0,7	PMR9B	4717		
Ultra 260LX	JT1500FAF		1500	4	2010-2010		0,7	PMR9B	4717		
Ultra 300X	JT1500HBF		1500	4	2011-2011		0,7	PMR9B	4717		
Ultra 300X	JT1500HCF		1500	4	2012-2012		0,7	PMR9B	4717		
Ultra 300X	JT1500HDF		1500	4	2013-2013		0,7	PMR9B	4717		
Ultra 300X	JT1500HBFA		1500	4	2011-2011		0,7	PMR9B	4717		
Ultra 300X	JT1500HCFA		1500	4	2012-2012		0,7	PMR9B	4717		
Ultra 300LX	JT1500JBF		1500	4	2011-2011		0,7	PMR9B	4717		
Ultra 300LX	JT1500JCF		1500	4	2012-2012		0,7	PMR9B	4717		
Ultra 300LX	JT1500JDF		1500	4	2013-2013		0,7	PMR9B	4717		
Ultra 310X	JT1500LEF	300	1500	4	2014-2014		0,7	PMR9B	4717		
Ultra 310X	JT1500LFF	300	1500	4	2015-2015		0,7	PMR9B	4717		
Ultra 310X	JT1500LGF	300	1500	4	2016-2016		0,7	PMR9B	4717		
Ultra 310X	JT1500LHF	300	1500	4	2017-2017		0,7	PMR9B	4717		
Ultra 310X	JT1500LJF	300	1500	4	2018-2018		0,7	PMR9B	4717		
Ultra 310LX	JT1500MEF	300	1500	4	2014-2014		0,7	PMR9B	4717		
Ultra 310LX	JT1500MFF	300	1500	4	2015-2015		0,7	PMR9B	4717		
Ultra 310LX	JT1500MGF	300	1500	4	2016-2016		0,7	PMR9B	4717		
Ultra 310LX	JT1500MHF	300	1500	4	2017-2017		0,7	PMR9B	4717		
Ultra 310LX	JT1500MJF	300	1500	4	2018-2018		0,7	PMR9B	4717		
Ultra 310R	JT1500NEF	300	1500	4	2014-2014		0,7	PMR9B	4717		
Ultra 310R	JT1500NFF	300	1500	4	2015-2015		0,7	PMR9B	4717		
Ultra 310R	JT1500NGF	300	1500	4	2016-2016		0,7	PMR9B	4717		
Ultra 310R	JT1500NHF	300	1500	4	2017-2017		0,7	PMR9B	4717		
Ultra 310R	JT1500NJF	300	1500	4	2018-2018		0,7	PMR9B	4717		
Ultra 310X SE	JT1500PEF	300	1500	4	2014-2014		0,7	PMR9B	4717		
Ultra 310X SE	JT1500PFF	300	1500	4	2015-2015		0,7	PMR9B	4717		
Ultra 310X SE	JT1500PGF	300	1500	4	2016-2016		0,7	PMR9B	4717		
Ultra 310X SE	JT1500PHF	300	1500	4	2017-2017		0,7	PMR9B	4717		
Ultra 310X SE	JT1500PJF	300	1500	4	2018-2018		0,7	PMR9B	4717		
Ultra LX	JT1500C7F	160	1500	4	2007-2007		0,8	CR9EK	4548	CR9EIX	3521
Ultra LX	JT1500C8F	160	1500	4	2008-2008		0,8	CR9EK	4548	CR9EIX	3521
Ultra LX	JT1500C9F	160	1500	4	2009-2009		0,8	CR9EK	4548	CR9EIX	3521
Ultra LX	JT1500GAF	160	1500	4	2010-2010		0,8	CR9EK	4548	CR9EIX	3521
Ultra LX	JT1500GBF	160	1500	4	2011-2011		0,8	CR9EK	4548	CR9EIX	3521
Ultra LX	JT1500KCF	160	1500	4	2012-2012		0,8	CR9EK	4548	CR9EIX	3521
Ultra LX	JT1500KDF	160	1500	4	2013-2013		0,8	CR9EK	4548	CR9EIX	3521
Ultra LX	JT1500KEF	160	1500	4	2014-2014		0,8	CR9EK	4548	CR9EIX	3521
Ultra LX	JT1500KFF	160	1500	4	2015-2015		0,8	CR9EK	4548	CR9EIX	3521
Ultra LX	JT1500KGF	160	1500	4	2016-2016		0,8	CR9EKB	2305	CR9EIX	3521
Ultra LX	JT1500KHF	160	1500	4	2017-2017		0,8	CR9EKB	2305	CR9EIX	3521
Ultra LX	JT1500KJF	160	1500	4	2018-2018		0,8	CR9EKB	2305	CR9EIX	3521



HP

c
c
mC
y
l

Stock-Nr



Stock-NrX

MASTERCRAFT

Duo 300	75	300	2	1995-1997	Wet-Jet	0,6	BR8HS	4322	BR8HIX	7001
Duo 200	50	432	2	1994-	Wet-Jet	0,8	BR8ES	5422	BR8EIX	5044
Duo		700		1995-1997	Wet-Jet	0,6	BR8HS	4322	BR8HIX	7001
Kraze		700		1995-1997	Wet-Jet	0,6	BR8HS	4322	BR8HIX	7001
ZX		700		1995-1997	Wet-Jet	0,6	BR8HS	4322	BR8HIX	7001

NAUTICA

Mercury	90			-		1,0	BZ7HS-10	3579		
Mercury	120			-		1,0	BZ7HS-10	3579		

POLARIS

SL	68	650	3	1994-1995		0,7	BPR7ES	2023	BPR7EIX	4055
STD	68	650	3	1995-1995		0,7	BPR7ES	2023	BPR7EIX	4055
Hurricane	95	700	2	1996-1997		0,7	BPR8ES	3923	BPR8EIX	6684
Hurricane	95	700	2	1996-1997		0,7	BPR8ES	3923	BPR8EIX	6684
INT'L Hurricane	95	700	2	1996-1997		0,7	BPR8ES	3923	BPR8EIX	6684
INT'L Hurricane	95	700	2	1996-1997		0,7	BPR8ES	3923	BPR8EIX	6684
SL	80	700	2	1996-1996		0,7	BPR7ES	2023	BPR7EIX	4055
INT'L SL	80	700	2	1996-1996		0,7	BPR7ES	2023	BPR7EIX	4055
SLT	80	700	2	1996-1999		0,7	BPR7ES	2023	BPR7EIX	4055
INT'L SLT	80	700	2	1996-1999		0,7	BPR7ES	2023	BPR7EIX	4055
SL	80	700	2	1997-1997		0,7	BPR8ES	3923	BPR8EIX	6684
INT'L SL	80	700	2	1997-1997		0,7	BPR8ES	3923	BPR8EIX	6684
SL Deluxe	85	700	2	1997-1997		0,7	BPR7ES	2023	BPR7EIX	4055
INT'L SL Deluxe	85	700	2	1997-1997		0,7	BPR7ES	2023	BPR7EIX	4055
SLH	95	700	2	1998-2001		0,7	BPR8ES	3923	BPR8EIX	6684
INT'L SLH	95	700	2	1998-2001		0,7	BPR8ES	3923	BPR8EIX	6684
SLTH	95	700	2	1998-1999		0,7	BPR8ES	3923	BPR8EIX	6684
INT'L SLTH	95	700	2	1998-1999		0,7	BPR8ES	3923	BPR8EIX	6684
VIRAGE		700	2	2000-2004		0,7	BPR8ES	3923	BPR8EIX	6684
INT'L VIRAGE		700	2	2000-2004		0,7	BPR8ES	3923	BPR8EIX	6684
Freedom		700	2	2002-2004		0,7	BPR8ES	3923	BPR8EIX	6684
INT'L Freedom		700	2	2002-2004		0,7	BPR8ES	3923	BPR8EIX	6684
SL	78	750	3	1993-1993		0,7	BPR7ES	2023	BPR7EIX	4055
SL	80	750	3	1994-1995		0,7	BPR7ES	2023	BPR7EIX	4055
SLT	80	750	3	1994-1995		0,7	BPR7ES	2023	BPR7EIX	4055
MSX 110		750	2	2004-		0,7	BKR7E	6097	BKR7EIX	2667
MSX 150	150	750	2	2004-		0,7	BKR7E	6097	BKR7EIX	2667
Octane		777	2	2002-2004		0,7	BR9ES	5722	BR9EIX	3981
Virage I		777	2	2002-2004		0,7	PZFR6H	7696		
INT'L Virage I		777	2	2002-2004		0,7	PZFR6H	7696		
SLX	90	780	3	1995-1996		0,7	BPR8ES	3923	BPR8EIX	6684
INT'L SLX	90	780	3	1995-1996		0,7	BPR8ES	3923	BPR8EIX	6684
SL	90	780	3	1996-1996		0,7	BPR8ES	3923	BPR8EIX	6684
SLT	90	780	3	1996-1996		0,7	BPR8ES	3923	BPR8EIX	6684
INT'L SLT	90	780	3	1996-1996		0,7	BPR8ES	3923	BPR8EIX	6684
SL	95	780	3	1997-1997		0,7	BPR8ES	3923	BPR8EIX	6684
INT'L SL	95	780	3	1997-1997		0,7	BPR8ES	3923	BPR8EIX	6684
SLT	95	780	3	1997-1997		0,7	BPR8ES	3923	BPR8EIX	6684



HP

c
c
mC
y
l

Stock-Nr





FRIDUM

Stock-NrX

SL PRO		785	3	1997-2000		0,7	BR9ES	5722	BR9EIX	3981
INT'L SL PRO		785	3	1997-2000		0,7	BR9ES	5722	BR9EIX	3981
SL	100	900	3	1996-1996		0,7	BPR8ES	3923	BPR8EIX	6684
INT'L SL	100	900	3	1996-1996		0,7	BPR8ES	3923	BPR8EIX	6684
SL	110	900	3	1997-1997		0,7	BPR8ES	3923	BPR8EIX	6684
SLTX	115	1050	3	1996-1997		0,7	BPR8ES	3923	BPR8EIX	6684
INT'L SLTX	115	1050	3	1996-1997		0,7	BPR8ES	3923	BPR8EIX	6684
SL	120	1050	3	1997-1997		0,7	BPR8ES	3923	BPR8EIX	6684
SLTX	120	1050	3	1998-1998		0,7	BPR8ES	3923	BPR8EIX	6684
INT'L SLTX	120	1050	3	1998-1998		0,7	BPR8ES	3923	BPR8EIX	6684
SLXH	120	1050	3	1998-1998		0,7	BPR8ES	3923	BPR8EIX	6684
SLTX	120	1050	3	1999-1999		0,7	BPR8ES	3923	BPR8EIX	6684
INT'L SLTX		1050	3	1999-1999		0,7	BPR8ES	3923	BPR8EIX	6684
SLX		1050	3	1999-		0,7	BPR8ES	3923	BPR8EIX	6684
INT'L SLX		1050	3	1999-		0,7	BPR8ES	3923	BPR8EIX	6684
GENESIS		1200	3	1999-1999		0,7	BPR8ES	3923	BPR8EIX	6684
GENESIS		1200	3	1999-1999		0,7	BPR8ES	3923	BPR8EIX	6684
INT'L GENESIS		1200	3	1999-1999		0,7	BPR8ES	3923	BPR8EIX	6684
INT'L GENESIS		1200	3	1999-1999		0,7	BPR8ES	3923	BPR8EIX	6684
GENESIS FICHT		1200	3	1999-1999		0,8	IZFR6N-E	4757		
INT'L GENESIS FICHT		1200	3	1999-1999		0,8	IZFR6N-E	4757		
SLTX-B		1200	3	1999-1999		0,7	BPR8ES	3923	BPR8EIX	6684
X45		1200	3	1999-		0,7	BR9ES	5722	BR9EIX	3981
GENESIS		1200	3	2000-2002		0,7	BR9ES	5722	BR9EIX	3981
INT'L GENESIS		1200	3	2000-2002		0,7	BR9ES	5722	BR9EIX	3981
GENESIS		1200	3	2000-2000		0,8	PZFR6H	7696		
INT'L GENESIS FFI		1200	3	2000-2000		0,8	PZFR6H	7696		
GENESIS I		1200	3	2000-2004		0,8	PZFR6H	7696		
INT'L GENESIS I		1200	3	2000-2004		0,8	PZFR6H	7696		
PRO 1200		1200	3	2000-2001		0,7	BR9ES	5722	BR9EIX	3981
INT'L PRO 1200		1200	3	2000-2001		0,7	BR9ES	5722	BR9EIX	3981
SLX		1200	3	2000-2001		0,7	BR9ES	5722	BR9EIX	3981
INT'L SLX		1200	3	2000-2001		0,7	BR9ES	5722	BR9EIX	3981
VIRAGE TX		1200	3	2000-2002		0,7	BR9ES	5722	BR9EIX	3981
INT'L VIRAGE TX		1200	3	2000-2002		0,7	BR9ES	5722	BR9EIX	3981
VIRAGE TXI		1200	3	2001-2004		0,8	PZFR6H	7696		
INT'L VIRAGE TXI		1200	3	2001-2004		0,8	PZFR6H	7696		
MSX 140		1200	3	2003-2004		0,8	PZFR6H	7696		

SEA-DOO / BOMBARDIER

5801		580		1988-		0,7	BR7ES	5122	BR7EIX	6664
5802		580		1989-		0,7	BR7ES	5122	BR7EIX	6664
5803		580		1990-		0,7	BR7ES	5122	BR7EIX	6664
5810		580		1990-		0,7	BR7ES	5122	BR7EIX	6664
EXP		580	2	1993-1993		0,6	BR7ES	5122	BR7EIX	6664
EXP	27	580	2	1994-1994		0,6	BR8ES	5422	BR8EIX	5044
SP	18,4	580	2	1988-1995		0,6	BR7ES	5122	BR7EIX	6664
SP	24,5	580	2	1996-1996		0,6	BR7ES	5122	BR7EIX	6664
SPi	20,2	580	2	1993-1995		0,6	BR7ES	5122	BR7EIX	6664
SPi	29,1	580	2	1996-1996		0,6	BR7ES	5122	BR7EIX	6664
SPX		580	2	1993-1993		0,6	BR7ES	5122	BR7EIX	6664
GTS	20,2	580	2	1992-1995		0,6	BR7ES	5122	BR7EIX	6664

	HP	c c m	C y l					Stock-Nº	TRIDIUM	Stock-NºX
GTS	29,1	580	2	1996-1996		0,6	BR7ES	5122	BR7EIX	6664
GTS	29	580	2	1997-1997		0,6	BR8ES	5422	BR8EIX	5044
SP Barracuda Premium 6157/6158		610		2004-		0,6	BR8ES	5422	BR8EIX	5044
SPX	27	650	2	1994-1994		0,6	BR8ES	5422	BR8EIX	5044
SPX	30,8	650	2	1995-1995		0,6	BR8ES	5422	BR8EIX	5044
GTX	31,1	650	2	1994-1995		0,6	BR8ES	5422	BR8EIX	5044
XPi	27	650	2	1995-1995		0,6	BR8ES	5422	BR8EIX	5044
SP	24,5	720	2	1997-1997		0,6	BR7ES	5122	BR7EIX	6664
SPX	47,4	720	2	1996-1996		0,6	BR8ES	5422	BR8EIX	5044
GS	46,8	720	2	1997-1997		0,6	BR8ES	5422	BR8EIX	5044
GS	35,3	720	2	1998-2001		0,6	BR8ES	5422	BR8EIX	5044
Gsi	46,8	720	2	1996-1997		0,6	BR8ES	5422	BR8EIX	5044
GTS	46,8	720	2	1997-1997		0,6	BR8ES	5422	BR8EIX	5044
GTS	48	720	2	1998-1998		0,6	BR8ES	5422	BR8EIX	5044
GTS	32	720	2	1999-2001		0,6	BR8ES	5422	BR8EIX	5044
XP	31,5	720	2	1995-1995		0,6	BR8ES	5422	BR8EIX	5044
HX		720	2	1995-1995		0,6	BR8ES	5422	BR8EIX	5044
HX	46,8	720	2	1996-1997		0,6	BR8ES	5422	BR8EIX	5044
GTi	34,9	720	2	1998-1998		0,6	BR8ES	5422	BR8EIX	5044
GTi	33,8	720	2	1999-2003		0,6	BR8ES	5422	BR8EIX	5044
GTi	33,8	720	2	2004-2005		0,6	BR8ES	5422	BR8EIX	5044
GTi - LE	33,8	720	2	2002-2003		0,6	BR8ES	5422	BR8EIX	5044
GTi - LE	33,8	720	2	2004-2004		0,6	BR8ES	5422	BR8EIX	5044
SPX	57	780	2	1997-1997		0,6	BR8ES	5422	BR8EIX	5044
SPX	46	780	2	1998-1999		0,6	BR8ES	5422	BR8EIX	5044
GSX	57	780	2	1996-1997		0,6	BR8ES	5422	BR8EIX	5044
GSX - RFI	44,9	780	2	1999-2001		0,6	BR8ES	5422	BR8EIX	5044
GTX	57	780	2	1996-1997		0,6	BR8ES	5422	BR8EIX	5044
GTX - RFI	41	780	2	2000-2002		0,6	BR8ES	5422	BR8EIX	5044
3D - RFI	85	780	2	2004-2005		0,6	BR8ES	5422	BR8EIX	5044
XP	56	780	2	1996-1997		0,6	BR8ES	5422	BR8EIX	5044
GTi	46,8	780	2	1996-1997		0,6	BR8ES	5422	BR8EIX	5044
GTi - LE RFI	40,7	780	2	2003-2005		0,6	BR8ES	5422	BR8EIX	5044
GTi - RFI	40,7	780	2	2004-2004		0,6	BR8ES	5422	BR8EIX	5044
GTi - RFI STD	85	780	2	2005-2005		0,6	BR8ES	5422	BR8EIX	5044
GTi 90	90	899	3	2017-		0,6	CR8EB	7784		
GTi 90	60	899	3	2017-		0,6	CR8EB	7784		
Spark 900 Ace - 2 up	60	900	3	2014-2016		0,6	CR8EB	7784	CR8EIX	4218
Spark 900 Ace	60	900	3	2017-		0,6	CR8EB	7784	CR8EIX	4218
Spark 900 HO ACE - 2 up	90	900	3	2014-2016		0,6	CR8EB	7784	CR8EIX	4218
Spark 900 HO ACE - 3 up	90	900	3	2014-2016		0,6	CR8EB	7784	CR8EIX	4218
Spark 900 HO ACE	90	900	3	2017-		0,6	CR8EB	7784	CR8EIX	4218
Spark Trixx	90	900	3	2017-		0,6	CR8EB	7784	CR8EIX	4218
Spark Trixx	90	900	3	2017-		0,6	CR8EB	7784	CR8EIX	4218
GTS - 90	60	900	3	2017-		0,6	CR8EB	7784		
GTS - 90	90	900	3	2017-		0,6	CR8EB	7784		
GSX - LTD	74,9	950	2	1998-1998		0,6	BR8ES	5422	BR8EIX	5044
GSX - LTD	71,1	950	2	1999-1999		0,6	BR8ES	5422	BR8EIX	5044
GTX - LTD	68,4	950	2	1998-1999		0,6	BR8ES	5422	BR8EIX	5044
GTX	68,4	950	2	2000-2002		0,5	BR8ES	5422	BR8EIX	5044
GTX - DI	67,3	950	2	2000-2001		1,1	ZFR4F-11	4043		
GTX - DI	70	950	2	2002-2002		1,1	ZFR4F-11	4043		
GTX - DI	68,4	950	2	2003-2003		1,1	ZFR4F-11	4043		



HP





c
c
mC
y
l

Stock-Nº

FRIDUM

Stock-NºX

XP - LTD	70,4	950	2	1998-1998		0,6	BR8ES	5422	BR8EIX	5044
XP - LTD	71,1	950	2	1999-1999		0,6	BR8ES	5422	BR8EIX	5044
XP	71,1	950	2	2000-2002		0,6	BR8ES	5422	BR8EIX	5044
XP - DI	72	950	2	2003-2004		1,1	ZFR4F-11	4043		
3D 947		950	2	2006-2007		1,1	ZFR4F-11	4043		
LRV		950	2	2000-2001		0,6	BR8ES	5422	BR8EIX	5044
LRV DI	67,3	950	2	2002-2003		1,1	ZFR4F-11	4043		
RX	68	950	2	2000-2002		0,5	BR8ES	5422	BR8EIX	5044
RX - DI	69,8	950	2	2000-2000		0,8	ZFR5F	5165		
RX - DI	67	950	2	2001-2002		1,1	ZFR4F-11	4043		
RX - DI (LE)	67	950	2	2002-2002		1,1	ZFR4F-11	4043		
RX - DI	71,9	950	2	2003-2003		1,1	ZFR4F-11	4043		
RX-X	60	950	2	2001-2001		0,6	BR8ES	5422	BR8EIX	5044
GTi		1500	3	2015-2015		0,7	DCP-R8E	4339		
GTX	71	1500	3	2005-2005		0,7	DCP-R8E	4339	DCPR8EIX	6546
GTX SC	83	1500	3	2005-2005		0,7	DCP-R8E	4339	DCPR8EIX	6546
Gti - STD		1500	3	2006-2006		0,7	DCPR8E	4339	DCPR8EIX	6546
GTi - SE		1500	3	2006-2006		0,7	DCPR8E	4339	DCPR8EIX	6546
Gti - Rental		1500	3	2006-2006		0,7	DCPR8E	4339	DCPR8EIX	6546
GTi - 130		1500	3	2008-2010		0,7	DCP-R8E	4339		
GTi - 130		1500	3	2011-2013		0,7	DCP-R8E	4339		
GTi - 130		1500	3	2014-2015		0,7	DCP-R8E	4339		
GTi - 130	130	1500	3	2016-		0,7	DCP-R8E	4339		
GTi - 130 SE		1500	3	2008-2010		0,7	DCP-R8E	4339		
Gti - 130 SE		1500	3	2011-2013		0,7	DCP-R8E	4339		
GTi 130 SE		1500	3	2011-2013		0,7	DCP-R8E	4339	DCPR8EIX	6546
Gti - 130 SE		1500	3	2014-2015		0,7	DCP-R8E	4339		
Gti - Rental 130		1500	3	2008-2010		0,7	DCP-R8E	4339	DCPR8EIX	6546
Gti - 155 LTD		1500	3	2011-2013		0,7	DCP-R8E	4339		
GTi - 155 LTD		1500	3	2014-2015		0,7	DCP-R8E	4339		
Gti - 155 SE		1500	3	2008-2010		0,7	DCP-R8E	4339		
Gti - 155 SE		1500	3	2011-2013		0,7	DCP-R8E	4339		
Gti - 155 SE		1500	3	2014-2015		0,7	DCP-R8E	4339		
Gti - 155		1500	3	2016-2016		0,7	DCP-R8E	4339		
Gti - 155	144	1500	3	2017-		0,7	DCP-R8E	4339		
GTi 4-Tec SE		1500	3	2007-2007		0,7	DCP-R8E	4339	DCPR8EIX	6546
GTi 4-Tec SE		1500	3	2007-2007		0,7	DCP-R8E	4339	DCPR8EIX	6546
GTi 4-Tec Rental		1500	3	2007-2007		0,7	DCP-R8E	4339	DCPR8EIX	6546
GTi 4-Tec STD		1500	3	2007-2007		0,7	DCP-R8E	4339	DCPR8EIX	6546
GTR - 215		1500	3	2012-2013		0,7	DCP-R8E	4339	DCPR8EIX	6546
GTR - 215		1500	3	2014-2016		0,7	DCP-R8E	4339	DCPR8EIX	6546
GTR - 230	230	1500	3	2017-		0,7	DCP-R8E	4339	DCPR8EIX	6546
GTS - 130		1500	3	2011-2013		0,7	DCP-R8E	4339	DCPR8EIX	6546
GTS 130		1500	3	2014-2016		0,7	DCP-R8E	4339	DCPR8EIX	6546
GTS 130 Rental		1500	3	2011-2013		0,7	DCP-R8E	4339	DCPR8EIX	6546
GTS 130 Rental		1500	3	2014-2016		0,7	DCP-R8E	4339	DCPR8EIX	6546
GTS Pro 130		1500	3	2011-2011		0,7	DCP-R8E	4339	DCPR8EIX	6546
GTX - 4-TEC	76,4	1500	3	2002-2002		0,8	DCP-R8E	4339	DCPR8EIX	6546
GTX - 4-TEC	70,5	1500	3	2003-2004		0,8	DCP-R8E	4339	DCPR8EIX	6546
GTX - 4-TEC		1500	3	2007-2007		0,8	DCP-R8E	4339	DCPR8EIX	6546
GTX - 4-TEC		1500	3	2007-2007		0,8	DCP-R8E	4339	DCPR8EIX	6546
GTX - 4-Tec	155	1500		2004-2005		0,7	DCP-R8E	4339	DCPR8EIX	6546
GTX - 4-Tec	155	1500		2008-2014		0,7	DCP-R8E	4339	DCPR8EIX	6546

	HP	c c m	C y l					Stock-Nº	FRIBUM	Stock-NºX
GTX - LTD	102	1500	3	2005-2005		0,7	DCP-R8E	4339	DCPR8EIX	6546
GTX - LTD	114	1500	3	2006-2007		0,7	DCP-R8E	4339	DCPR8EIX	6546
GTX - 4-Tec LTD	155	1500		2011-2014		0,7	DCP-R8E	4339	DCPR8EIX	6546
GTX - 4-TEC LTD Supercharged	82,7	1500	3	2003-2004		0,7	DCP-R8E	4339	DCPR8EIX	6546
GTX - 4-TEC Supercharged	82,7	1500	3	2003-2006		0,7	DCP-R8E	4339	DCPR8EIX	6546
GTX - 4-TEC Special Supercharged	82,7	1500	3	2004-2004		0,8	DCP-R8E	4339	DCPR8EIX	6546
GTX - 4-TEC STD		1500	3	2005-2006		0,7	DCP-R8E	4339	DCPR8EIX	6546
GTX - 4-TEC Wake	71	1500	3	2003-2006		0,8	DCP-R8E	4339	DCPR8EIX	6546
GTX - 4-TEC Wake		1500	3	2007-2007		0,8	DCP-R8E	4339	DCPR8EIX	6546
GTX - 155		1500	3	2008-2009		0,8	DCP-R8E	4339	DCPR8EIX	6546
GTX - 155		1500	3	2010-2013		0,8	DCP-R8E	4339	DCPR8EIX	6546
GTX - 155		1500	3	2014-2016		0,8	DCP-R8E	4339	DCPR8EIX	6546
GTX - 155		1500	3	2017-2017		0,8	DCP-R8E	4339	DCPR8EIX	6546
GTX - 155	144	1500	3	2018-		0,8	DCP-R8E	4339	DCPR8EIX	6546
GTX - 215 iS		1500	3	2010-2013		0,8	DCP-R8E	4339	DCPR8EIX	6546
GTX - 215		1500	3	2008-2009		0,8	DCP-R8E	4339	DCPR8EIX	6546
GTX - 215		1500	3	2011-2013		0,8	DCP-R8E	4339	DCPR8EIX	6546
GTX - 215		1500	3	2014-2016		0,8	DCP-R8E	4339	DCPR8EIX	6546
GTX - LTD 215		1500	3	2008-2008		0,8	DCPR8E	4339	DCPR8EIX	6546
GTX - LTD 215		1500	3	2014-2014		0,8	DCPR8E	4339	DCPR8EIX	6546
GTX - LTD iS 255		1500	3	2009-2009		0,8	DCPR8E	4339	DCPR8EIX	6546
GTX - LTD iS 260		1500	3	2010-2013		0,8	DCPR8E	4339	DCPR8EIX	6546
GTX - LTD iS 260		1500	3	2014-2016		0,8	DCPR8E	4339	DCPR8EIX	6546
GTX - LTD 260		1500	3	2017-2017		0,8	DCPR8E	4339	DCPR8EIX	6546
GTX - S 155		1500	3	2012-2013		0,8	DCP-R8E	4339	DCPR8EIX	6546
GTX - S 155		1500	3	2014-2016		0,8	DCP-R8E	4339	DCPR8EIX	6546
GTX - S 155		1500	3	2017-2017		0,8	DCP-R8E	4339	DCPR8EIX	6546
GTX - 230		1500	3	2017-2017		0,8	DCPR8E	4339	DCPR8EIX	6546
GTX - 230		1500	3	2018-		0,8	DCPR8E	4339	DCPR8EIX	6546
RS	255	1500		2009-2011		0,8	DCP-R8E	4339	DCPR8EIX	6546
RXP - 4-TEC	103,9	1500	3	2004-2006		0,8	DCP-R8E	4339	DCPR8EIX	6546
RXP - 4-TEC		1500	3	2007-2007		0,8	DCP-R8E	4339	DCPR8EIX	6546
RXP - 4-TEC		1500	3	2007-2007		0,8	DCP-R8E	4339	DCPR8EIX	6546
RXP - 155	70,5	1500	3	2008-2008		0,8	DCP-R8E	4339	DCPR8EIX	6546
RXP - 215	104	1500	3	2008-2009		0,8	DCP-R8E	4339	DCPR8EIX	6546
RXP - X 255	119	1500	3	2008-2011		0,8	DCP-R8E	4339	DCPR8EIX	6546
RXP - X 260	243	1500	3	2012-2013		0,8	DCP-R8E	4339	DCPR8EIX	6546
RXP - X 260	243	1500	3	2014-2015		0,8	DCP-R8E	4339	DCPR8EIX	6546
RXT	102	1500	3	2005-2005		0,8	DCP-R8E	4339	DCPR8EIX	6546
RXT	114	1500	3	2006-2006		0,8	DCP-R8E	4339	DCPR8EIX	6546
RXT - 4-TEC		1500	3	2007-2007		0,8	DCP-R8E	4339	DCPR8EIX	6546
RXT - 215	114	1500	3	2008-2009		0,8	DCP-R8E	4339	DCPR8EIX	6546
RXT - 215		1500	3	2010-2010		0,8	DCP-R8E	4339	DCPR8EIX	6546
RXT - 230	230	1500	3	2017-		0,8	DCP-R8E	4339	DCPR8EIX	6546
RXT - 255		1500	3	2009-2009		0,8	DCP-R8E	4339	DCPR8EIX	6546
RXT - 255 iS		1500	3	2009-2009		0,8	DCP-R8E	4339	DCPR8EIX	6546
RXT - 255 RS		1500	3	2009-2009		0,8	DCP-R8E	4339	DCPR8EIX	6546
RXT - 260 iS		1500	3	2010-2012		0,8	DCP-R8E	4339	DCPR8EIX	6546
RXT - 260		1500	3	2011-2013		0,8	DCP-R8E	4339	DCPR8EIX	6546
RXT - 260		1500	3	2014-2015		0,8	DCP-R8E	4339	DCPR8EIX	6546
RXT - 260		1500	3	2016-2017		0,8	DCP-R8E	4339	DCPR8EIX	6546
RXT - 260 RS		1500	3	2011-2013		0,8	DCP-R8E	4339	DCPR8EIX	6546
RXT - 260 RS		1500	3	2014-2015		0,8	DCP-R8E	4339	DCPR8EIX	6546



HP

c
c
mC
y
l

Stock-Nº

FRIBUM

Stock-NºX

RXT - X aS 260		1500	3	2011-2013		0,8	DCP-R8E	4339	DCPR8EIX	6546
RXT - X aS 260		1500	3	2014-2016		0,8	DCP-R8E	4339	DCPR8EIX	6546
RXT - X aS 260 RS		1500	3	2011-2013		0,8	DCP-R8E	4339	DCPR8EIX	6546
RXT - X aS 260 RS		1500	3	2014-2015		0,8	DCP-R8E	4339	DCPR8EIX	6546
RXT - X 260		1500	3	2010-2013		0,8	DCP-R8E	4339	DCPR8EIX	6546
RXT - X 260		1500	3	2014-2015		0,8	DCP-R8E	4339	DCPR8EIX	6546
RXT - X 260 RS		1500	3	2010-2013		0,8	DCP-R8E	4339	DCPR8EIX	6546
RXT - X 260 RS		1500	3	2014-2015		0,8	DCP-R8E	4339	DCPR8EIX	6546
Wake - 155		1500	3	2008-2010		0,8	DCP-R8E	4339	DCPR8EIX	6546
Wake - 155		1500	3	2011-2013		0,8	DCP-R8E	4339	DCPR8EIX	6546
Wake - 155		1500	3	2014-2016		0,8	DCP-R8E	4339	DCPR8EIX	6546
Wake - 155		1500	3	2017-		0,8	DCP-R8E	4339	DCPR8EIX	6546
Wake - 215		1500	3	2008-2008		0,8	DCP-R8E	4339	DCPR8EIX	6546
Wake - PRO 215		1500	3	2009-2009		0,8	DCP-R8E	4339	DCPR8EIX	6546
Wake - PRO 215		1500	3	2010-2013		0,8	DCP-R8E	4339	DCPR8EIX	6546
Wake - PRO 215		1500	3	2014-2016		0,8	DCP-R8E	4339	DCPR8EIX	6546
Wake - PRO 230	230	1500	3	2017-		0,8	DCP-R8E	4339	DCPR8EIX	6546
GTX - LTD 300	300	1630	3	2016-2017		0,8	KR9C-G	90893		
GTX - 300	300	1630	3	2018-		0,8	KR9E-G	93226		
RXP - X 300	300	1630	3	2016-2017		0,8	KR9C-G	90893		
RXP - X 300	300	1630	3	2018-		0,8	KR9E-G	93226		
RXT - X 300	300	1630	3	2016-2017		0,8	KR9C-G	90893		
RXT - X 300	300	1630	3	2018-		0,8	KR9E-G	93226		

SEAFLAS

Eng. Suzuki				-	0,8		B6HS	4510	BR6HIX	3419
-------------	--	--	--	---	-----	--	------	------	--------	------

SKIDADDLE

Aquajet				-		0,8	BR7ES	5122	BR7EIX	6664
---------	--	--	--	---	--	-----	-------	------	--------	------

SKI-FREE

40 HP	40			-	0,6		BR8ES	5422	BR8EIX	5044
-------	----	--	--	---	-----	--	-------	------	--------	------

SKI-WHEE

Ski Tow		440		-		0,6	B9ES	2611	BR9EIX	3981
---------	--	-----	--	---	--	-----	------	------	--------	------

SOS EXPRESS







Tide Rider	45	428	2	-		0,6	BR8ES	5422	BR8EIX	5044
------------	----	-----	---	---	--	-----	-------	------	--------	------

SURF JET

Eng. Fuji LC 26		260		1980-1997	0,6		B7HS	5110	BR7HIX	7067
-----------------	--	-----	--	-----------	-----	--	------	------	--------	------

THUNDER JET

F14		440	2	-		0,6	BR8ES	5422	BR8EIX	5044
F15		550	2	-		0,6	BR8ES	5422	BR8EIX	5044
F - II 700		700		-		0,6	BR8ES	5422	BR8EIX	5044

	HP	c c m	C y l					Stock-Nº		Stock-NºX
F - II 800		800		-		0,6	BR8ES	5422	BR8EIX	5044
TIDE RIDER										
Eng. Cuyuna	45	428	2	-	0,6		BR8ES	5422	BR8EIX	5044
ULTRANAUTICS										
Wetbike	50	733	2	1978-1985		1,0	B7HS	5110	BR7HIX	7067
Seaflash ST		789	2	-		1,0	B7HS	5110	BR7HIX	7067
Seaflash XL		789	2	-		1,0	B7HS	5110	BR7HIX	7067
Seaflash XP		789	2	-		1,0	B7HS	5110	BR7HIX	7067
Wetbike	60	800	2	1986-		1,0	B7HS	5110	BR7HIX	7067
		800		1992-1992		1,0	BR8HS-10	1134	BR8HIX	7001
Jetstar 1260		800	2	1991-1991		1,0	B8HS-10	5126	BR8HIX	7001
Seaflash ST		800	2	1991-1991		1,0	B8HS-10	5126	BR8HIX	7001
Seaflash XL		800	2	1991-1991		1,0	B8HS-10	5126	BR8HIX	7001
Seaflash XP		800	2	1991-1991		1,0	B8HS-10	5126	BR8HIX	7001
Jetfisher 1670B		850		1990-1990		1,0	B8HS-10	5126	BR8HIX	7001
Riverjet 1670B		850		1990-1990		1,0	B8HS-10	5126	BR8HIX	7001
		1230		1992-1992		1,3	BUHW	2622		
WETBIKE										
Engine Spirit				-	1,0		B7HS	5110	BR7HIX	7067
Engine Suzuki				-	0,8		B6HS	4510	BR6HIX	3419
WILD CAT										
Brute	50			-		0,6	B9ES	2611	BR9EIX	3981
Brute	75			-		0,6	B9ES	2611	BR9EIX	3981
YAMAHA										
Wave Jammer	32	496	2	1987-1990		0,7	B7HS	5110	BR7HIX	7067
WRB650Q_FN		633	2	1991-1991		0,6	B8HS	5510	BR8HIX	7001
WRB650P_61	50	633	2	1991-1991		0,6	B8HS	5510	BR8HIX	7001
WR650P	42	633	2	1991-1991		0,6	B8HS	5510	BR8HIX	7001
WRB650Q_FN		633	2	1992-1992		0,6	B8HS	5510	BR8HIX	7001
WRB650Q_61		633	2	1992-1992		0,6	B8HS	5510	BR8HIX	7001
WRB650R_61		633	2	1993-1993		0,6	B8HS	5510	BR8HIX	7001
WRB650RA	50	633	2	1993-1993		0,6	B8HS	5510	BR8HIX	7001
Wave Runner LX	42	633	2	1990-1990		0,6	B8HS	5510	BR8HIX	7001
Wave Runner LX	42	633	2	1992-1993		0,6	B8HS	5510	BR8HIX	7001
Wave Runner		650	2	1987-1993		0,7	B7HS	5110	BR7HIX	7067
Wave Runner III		650	2	1990-1993		0,7	BR8HS	4322	BR8HIX	7001
Wave Runner VXR		650	2	1993-1995		0,6	B8HS	5510	BR8HIX	7001
Wave Runner Pro VXR		650	2	1993-1994		0,7	BR8HS	4322	BR8HIX	7001
Wave Runner III		700	2	1995-1997		0,7	BR8HS	4322	BR8HIX	7001
FX - 1		700	2	1994-1995		0,6	B8HS	5510	BR8HIX	7001
Super Jet	SJ700S / T / AU	700	2	1994-1996		0,6	B8HS	5510	BR8HIX	7001
Super Jet	SJ700AV	700	2	1997-1997		0,6	B7HS	5110	BR7HIX	7067
Super Jet	SJ700AW	700	2	1998-1998		0,6	B8HS	5510	BR8HIX	7001



HP

c
mC
y
l

Stock-Nr



Stock-NrX

Super Jet	SJ700AX / AY		700	2	1999-2000		0,6	B7HS	5110	BR7HIX	7067
Super Jet	SJ700AZ / AA / BA / BB / BC / BD / BE / BF / BG / BH / BJ / BK / BL / BM / BN		700	2	2001-2014		0,6	B7HS	5110	BR7HIX	7067
Wave Raider			700	2	1994-1995		0,7	BR8HS	4322	BR8HIX	7001
Wave Raider 700			700	2	1996-1997		0,6	B8HS	5510	BR8HIX	7001
Wave Raider 700			700	2	1997-1997		0,7	B7HS	5110	BR7HIX	7067
Wave Blaster			700	2	1993-1996		0,6	B8HS	5510	BR8HIX	7001
Wave Runner III GP			700	2	1994-1995		0,7	BR8HS	4322	BR8HIX	7001
Wave Venture 700	80		700	2	1995-1996		0,7	BR8HS	4322	BR8HIX	7001
Wave Venture 700			700	2	1998-1998		0,7	BR8HS	4322	BR8HIX	7001
RA700AT	80		701	2	1995-1995		0,7	BR8HS	4322	BR8HIX	7001
Wave Runner XL700	80		701	2	1999-2004		0,6	BR8HS	4322	BR8HIX	7001
Wave Runner GP760	90		754	2	1997-2000		0,7	BR8HS	4322	BR8HIX	7001
Wave Runner XL760	90		754	2	1998-1999		0,7	BR8HS	4322	BR8HIX	7001
Wave Raider 760			760	2	1996-1996		0,7	BR8HS	4322	BR8HIX	7001
Wave Blaster II			760	2	1996-1997		0,7	BR8HS	4322	BR8HIX	7001
Wave Venture 760			760	2	1997-1997		0,7	BR8HS	4322	BR8HIX	7001
Wave Runner GP800			784	2	1998-2000		0,8	BR8ES	5422	BR8EIX	5044
Wave Runner GP800R	120		784	2	2001-2005		0,8	BR8ES	5422	BR8EIX	5044
Wave Runner XL800	120		784	2	2000-2001		0,8	BR8ES	5422	BR8EIX	5044
Wave Runner XLT800	118		784	2	2002-2004		0,8	BR8ES	5422	BR8EIX	5044
FX	140		998	4	2005-2006		0,8	CR9EB	6955	CR9EIX	3521
FX 140	140		998	4	2002-2004		0,8	CR9EB	6955	CR9EIX	3521
FX Cruiser	140		998	4	2003-2006		0,8	CR9EB	6955	CR9EIX	3521
Wave Runner VX	115	1049	3	2016-		0,8	CR9EB	6955	CR9EIX	3521	
Wave Runner VX Cruiser	115	1049	3	2016-		0,8	CR9EB	6955	CR9EIX	3521	
Wave Runner VX Deluxe	115	1049	3	2016-		0,8	CR9EB	6955	CR9EIX	3521	
Wave Runner VX LTD	115	1049	3	2016-		0,8	CR9EB	6955	CR9EIX	3521	
Wave Runner V1	115	1049	3	2016-2016		0,8	CR9EB	6955	CR9EIX	3521	
Wave Runner V1 Sport	115	1049	3	2016-2016		0,8	CR9EB	6955	CR9EIX	3521	
EX	101	1050	3	2017-		0,8	CR9EB	6955	CR9EIX	3521	
EX Deluxe	101	1050	3	2017-		0,8	CR9EB	6955	CR9EIX	3521	
EX Sport	101	1050	3	2017-		0,8	CR9EB	6955	CR9EIX	3521	
Wave Runner VX	102	1052	4	2007-2009		0,8	CR9EB	6955	CR9EIX	3521	
Wave Runner VX	115	1052	4	2015-2015		0,8	CR9EB	6955	CR9EIX	3521	
Wave Runner VX Cruiser	102	1052	4	2007-2014		0,8	CR9EB	6955	CR9EIX	3521	
Wave Runner VX Cruiser	115	1052	4	2015-2015		0,8	CR9EB	6955	CR9EIX	3521	
Wave Runner VX Deluxe	102	1052	4	2007-2014		0,8	CR9EB	6955	CR9EIX	3521	
Wave Runner VX Deluxe	115	1052	4	2015-2015		0,8	CR9EB	6955	CR9EIX	3521	
Wave Runner VX 110 Deluxe	102	1052	4	2005-2006		0,8	CR9EB	6955	CR9EIX	3521	
Wave Runner VX 110 Sport	102	1052	4	2005-2008		0,8	CR9EB	6955	CR9EIX	3521	
Wave Runner VX Sport	102	1052	4	2010-2014		0,8	CR9EB	6955	CR9EIX	3521	
Wave Runner V1	115	1052	4	2015-2015		0,8	CR9EB	6955	CR9EIX	3521	
Wave Runner V1 Sport	115	1052	4	2015-2015		0,8	CR9EB	6955	CR9EIX	3521	
Wave Raider 1100			1100	3	1995-1996		0,7	BR8HS	4322	BR8HIX	7001
Wave Venture 1100			1100	3	1996-1997		0,7	BR8HS	4322	BR8HIX	7001
Wave Runner GP1200	135	1131	3	1997-1999		0,7	BR8HS	4322	BR8HIX	7001	
Wave Runner SUV1200	135	1131	3	1999-2004		0,6	BR8HS	4322	BR8HIX	7001	
Wave Runner XL1200	135	1131	3	1998-1998		0,7	BR8HS	4322	BR8HIX	7001	
Wave Runner GP1200	155	1176	3	2000-2002		1,1	BR8ES-11	7986	BR8EIX	5044	
Wave Runner XLT 1200 LTD	155	1176	3	1999-1999		0,8	BR8ES	5422	BR8EIX	5044	
Wave Runner XLT 1200 LTD	155	1176	3	2000-2000		1,1	BR8ES-11	7986	BR8EIX	5044	

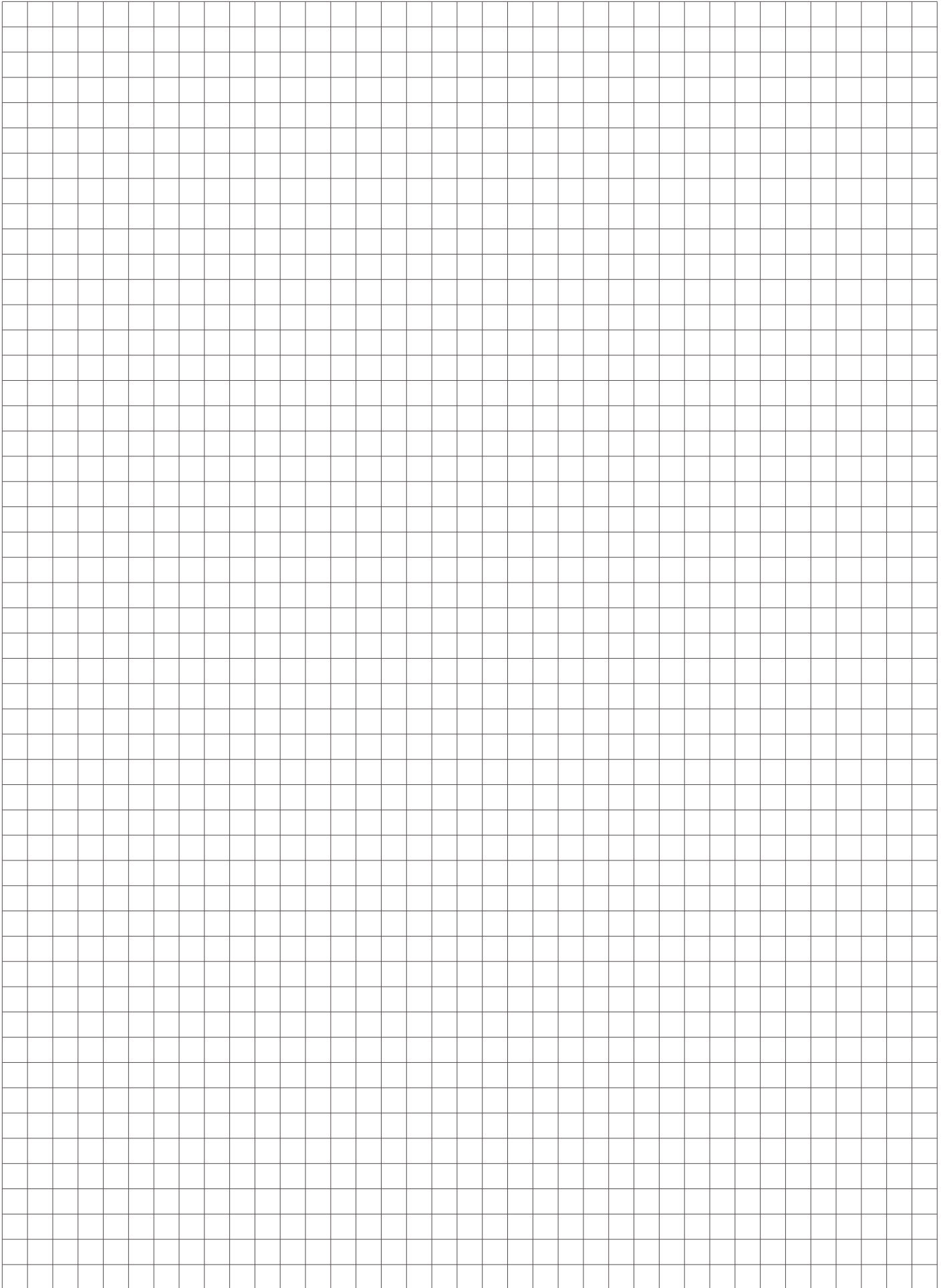



IGNITION
PARTS

NGK RESISTOR PLUG COVERS

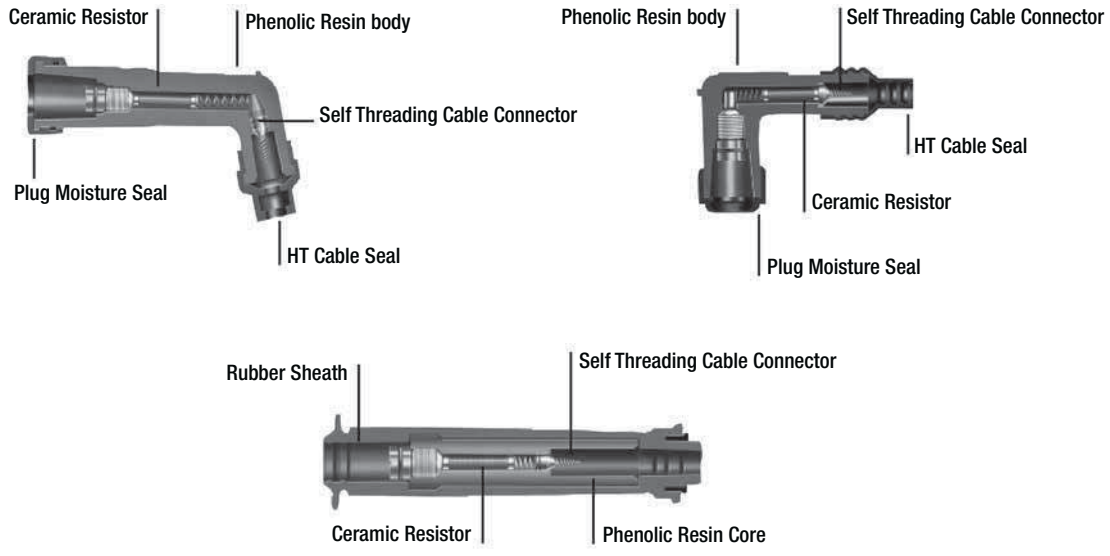

COVER SYMBOLS EXPLANATION CHART

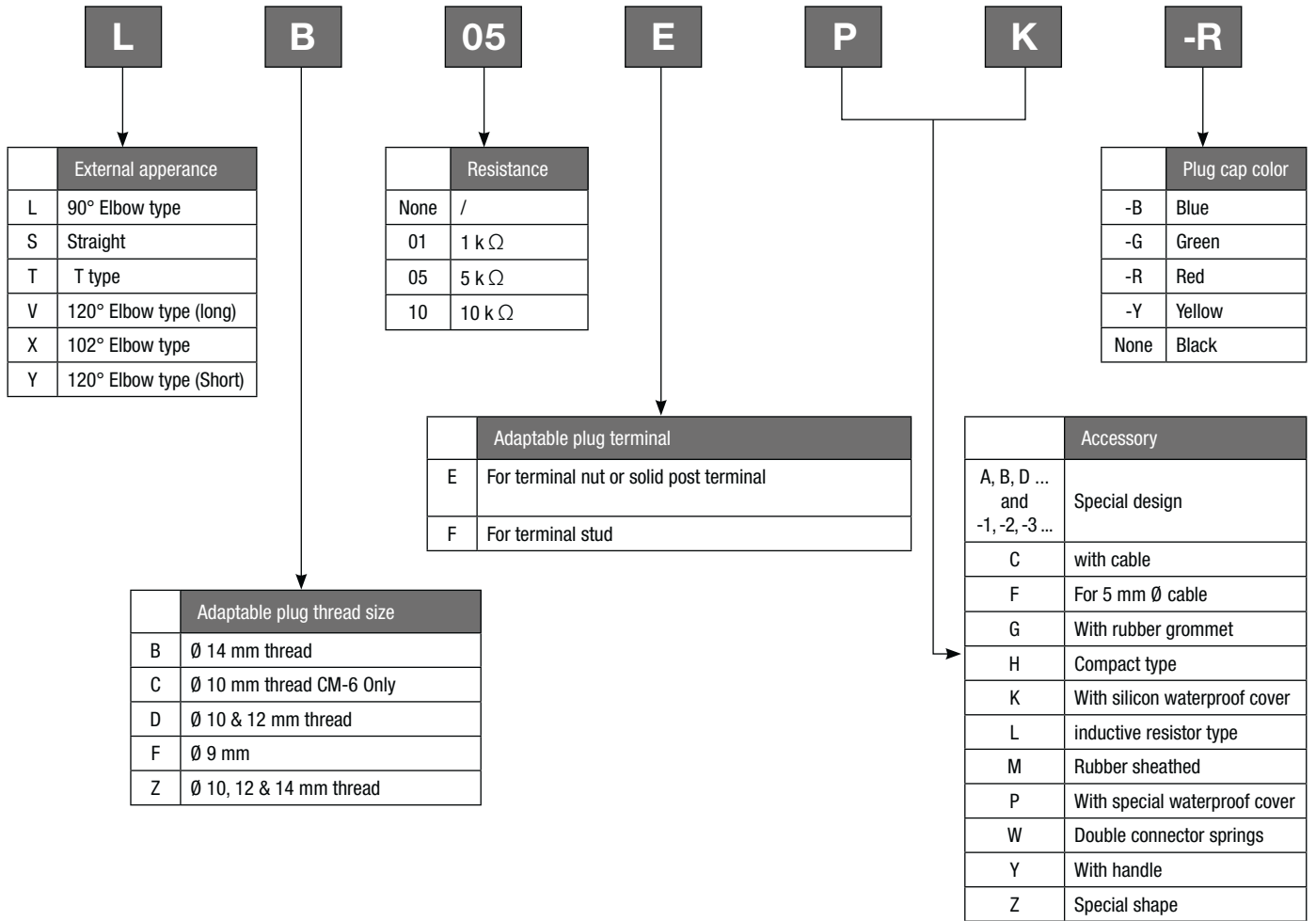

NGK ZÜNDKERZENSTECKER

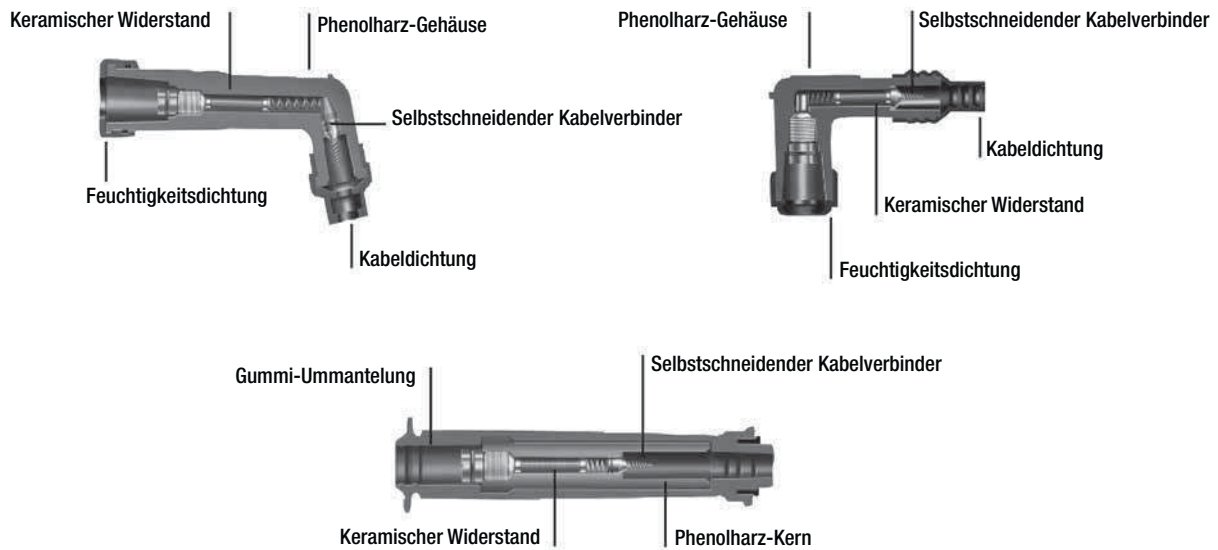

ERKLÄRUNG DER KURZZEICHEN

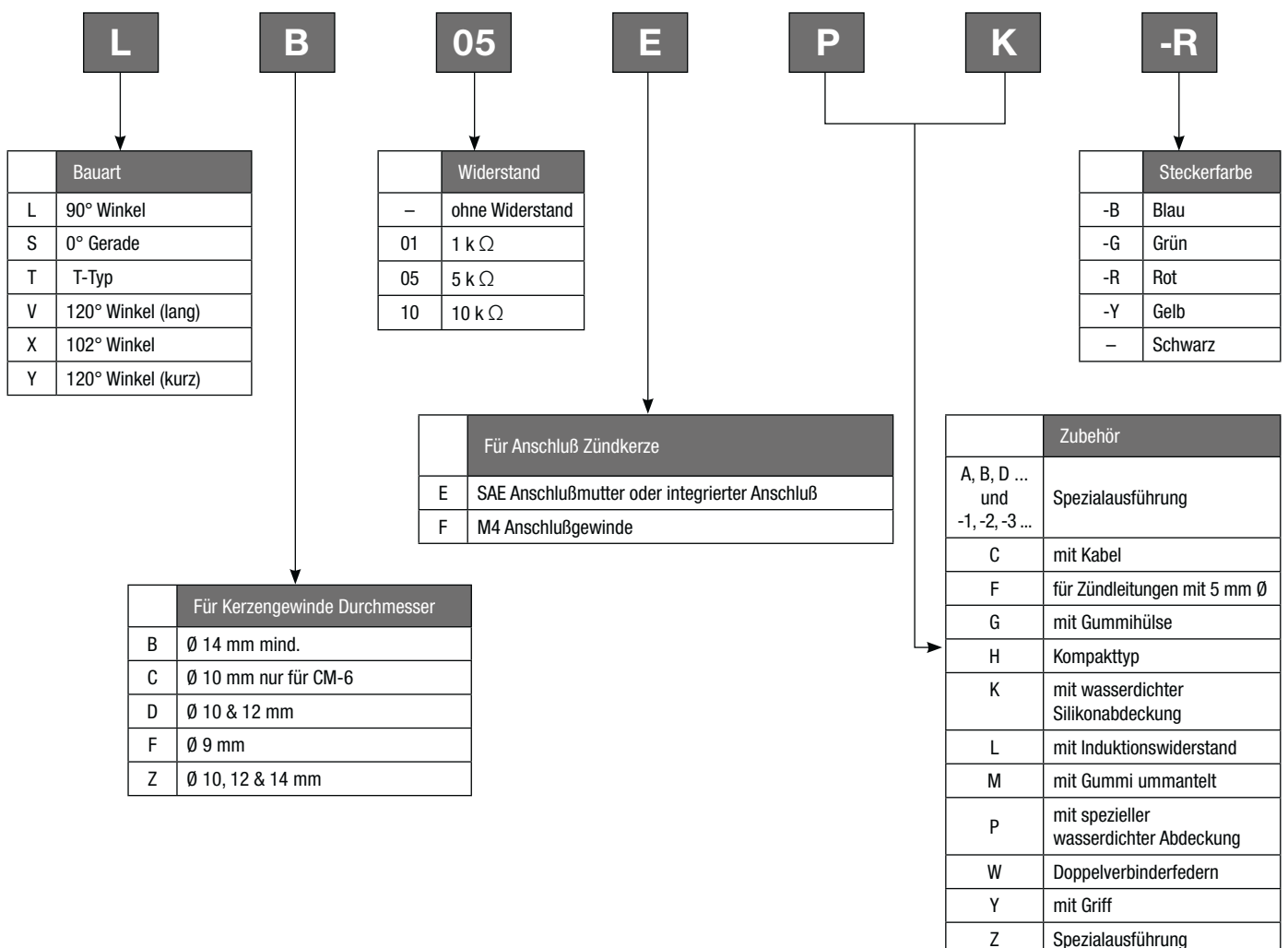

TECHNOLOGIES

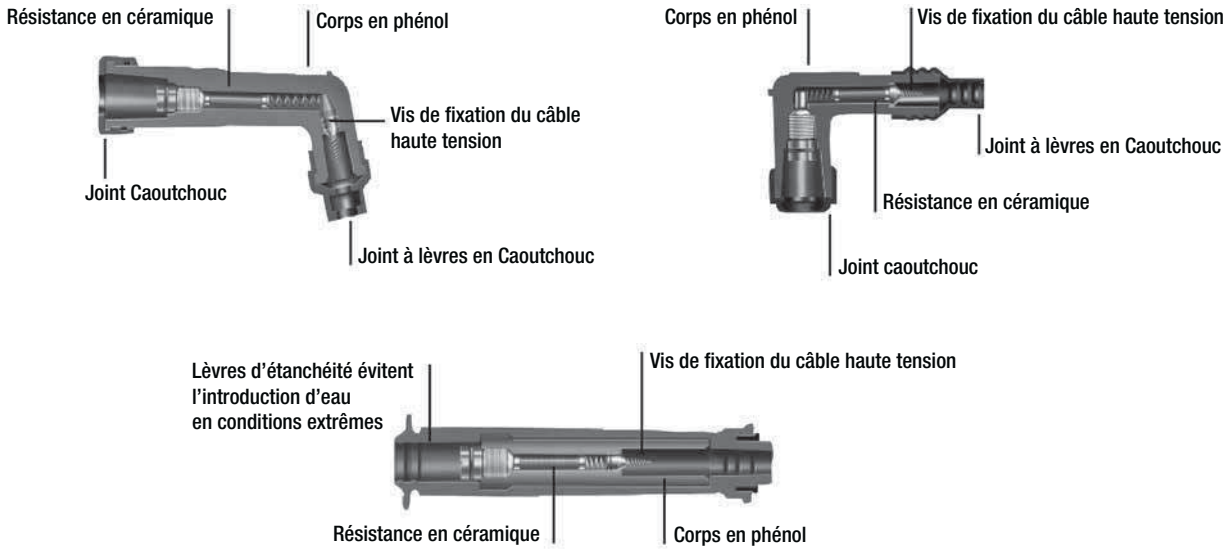

SIGNIFICATION DES RÉFÉRENCES

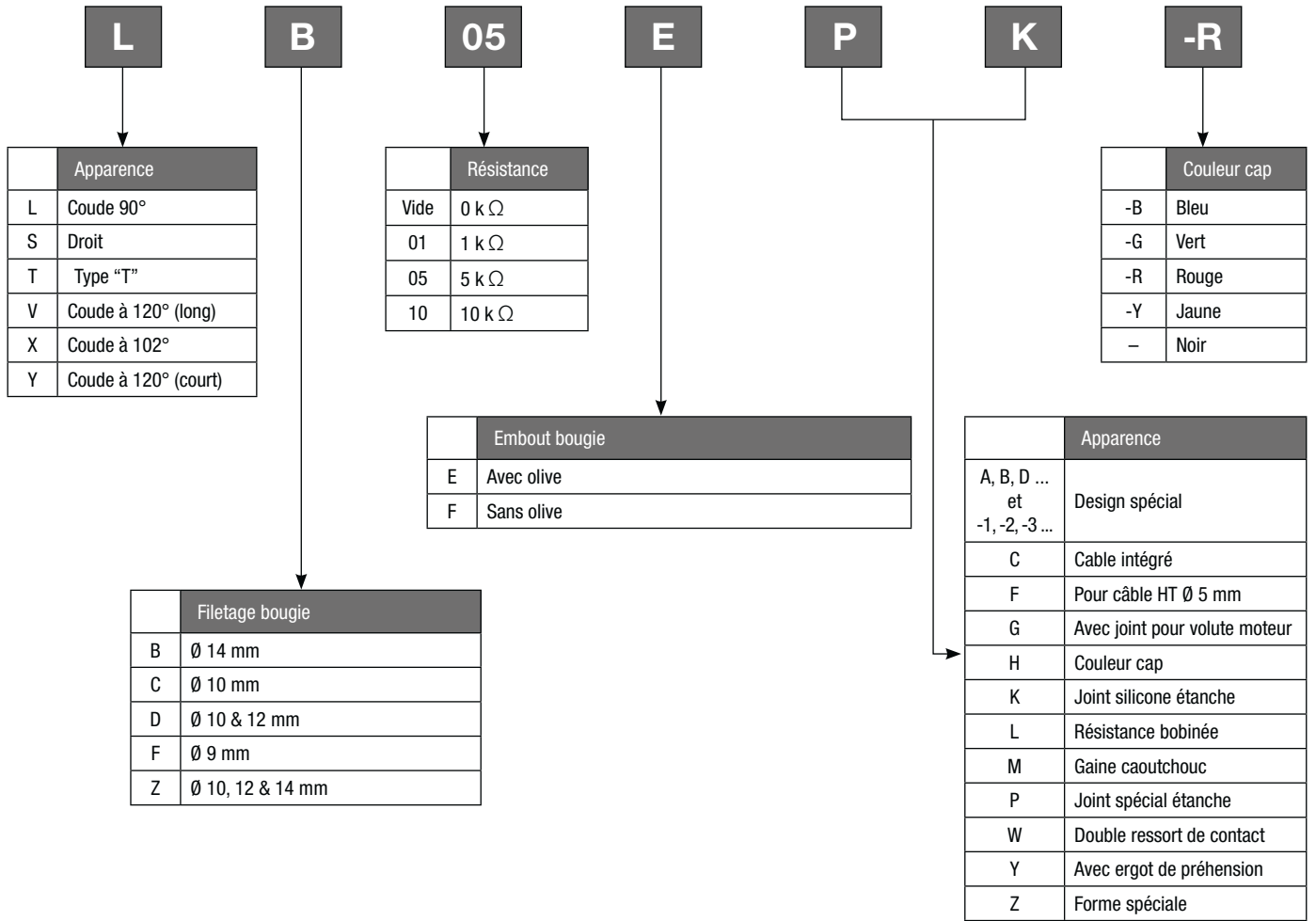

CAPPUCCI CANDELA CON RESISTORE NGK



TABELLA SPIEGAZIONE CODICI CAPPUCCI

L	B	05	E	P	K	-R																																																																																
<table border="1"> <thead> <tr> <th></th> <th>Aspetto esteriore</th> </tr> </thead> <tbody> <tr> <td>L</td> <td>Tipo gomito 90°</td> </tr> <tr> <td>S</td> <td>Dritto</td> </tr> <tr> <td>T</td> <td>Tipo T</td> </tr> <tr> <td>V</td> <td>Tipo gomito 120° (lungo)</td> </tr> <tr> <td>X</td> <td>Tipo gomito 102°</td> </tr> <tr> <td>Y</td> <td>Tipo gomito 120° (corto)</td> </tr> </tbody> </table>		Aspetto esteriore	L	Tipo gomito 90°	S	Dritto	T	Tipo T	V	Tipo gomito 120° (lungo)	X	Tipo gomito 102°	Y	Tipo gomito 120° (corto)	<table border="1"> <thead> <tr> <th></th> <th>Resistenza</th> </tr> </thead> <tbody> <tr> <td>Nessuna</td> <td>Nessun resistore</td> </tr> <tr> <td>01</td> <td>1 k Ω</td> </tr> <tr> <td>05</td> <td>5 k Ω</td> </tr> <tr> <td>10</td> <td>10 k Ω</td> </tr> </tbody> </table>		Resistenza	Nessuna	Nessun resistore	01	1 k Ω	05	5 k Ω	10	10 k Ω	<table border="1"> <thead> <tr> <th></th> <th>Terminale candela adattabile</th> </tr> </thead> <tbody> <tr> <td>E</td> <td>Per terminale con nottolino o terminale ad ogiva</td> </tr> <tr> <td>F</td> <td>Per terminale filettato</td> </tr> </tbody> </table>		Terminale candela adattabile	E	Per terminale con nottolino o terminale ad ogiva	F	Per terminale filettato	<table border="1"> <thead> <tr> <th></th> <th>Colore cappuccio candela</th> </tr> </thead> <tbody> <tr> <td>-B</td> <td>Blu</td> </tr> <tr> <td>-G</td> <td>Verde</td> </tr> <tr> <td>-R</td> <td>Rosso</td> </tr> <tr> <td>-Y</td> <td>Giallo</td> </tr> <tr> <td>Nessuno</td> <td>Nero</td> </tr> </tbody> </table>		Colore cappuccio candela	-B	Blu	-G	Verde	-R	Rosso	-Y	Giallo	Nessuno	Nero	<table border="1"> <thead> <tr> <th></th> <th>Dimensione filettatura della candela adattabile</th> </tr> </thead> <tbody> <tr> <td>B</td> <td>Filettatura Ø 14 mm</td> </tr> <tr> <td>C</td> <td>Filettatura Ø 10 mm Solo CM-6</td> </tr> <tr> <td>D</td> <td>Filettatura Ø 10 & 12 mm</td> </tr> <tr> <td>F</td> <td>Ø 9 mm</td> </tr> <tr> <td>Z</td> <td>Filettatura Ø 10, 12 & 14 mm</td> </tr> </tbody> </table>		Dimensione filettatura della candela adattabile	B	Filettatura Ø 14 mm	C	Filettatura Ø 10 mm Solo CM-6	D	Filettatura Ø 10 & 12 mm	F	Ø 9 mm	Z	Filettatura Ø 10, 12 & 14 mm	<table border="1"> <thead> <tr> <th></th> <th>Accessorio</th> </tr> </thead> <tbody> <tr> <td>A, B, D ... e -1, -2, -3 ...</td> <td>Design speciale</td> </tr> <tr> <td>C</td> <td>Con cavo</td> </tr> <tr> <td>F</td> <td>Per cavo 5 mm Ø</td> </tr> <tr> <td>G</td> <td>Con anello di tenuta in gomma</td> </tr> <tr> <td>H</td> <td>Tipo compatto</td> </tr> <tr> <td>K</td> <td>Con copertura in silicone impermeabile</td> </tr> <tr> <td>L</td> <td>Tipo resistore induttivo</td> </tr> <tr> <td>M</td> <td>Anello di tenuta in gomma</td> </tr> <tr> <td>P</td> <td>Con copertura speciale impermeabile</td> </tr> <tr> <td>W</td> <td>Molle del connettore doppio</td> </tr> <tr> <td>Y</td> <td>Con manico</td> </tr> <tr> <td>Z</td> <td>Forma speciale</td> </tr> </tbody> </table>		Accessorio	A, B, D ... e -1, -2, -3 ...	Design speciale	C	Con cavo	F	Per cavo 5 mm Ø	G	Con anello di tenuta in gomma	H	Tipo compatto	K	Con copertura in silicone impermeabile	L	Tipo resistore induttivo	M	Anello di tenuta in gomma	P	Con copertura speciale impermeabile	W	Molle del connettore doppio	Y	Con manico	Z	Forma speciale	
	Aspetto esteriore																																																																																					
L	Tipo gomito 90°																																																																																					
S	Dritto																																																																																					
T	Tipo T																																																																																					
V	Tipo gomito 120° (lungo)																																																																																					
X	Tipo gomito 102°																																																																																					
Y	Tipo gomito 120° (corto)																																																																																					
	Resistenza																																																																																					
Nessuna	Nessun resistore																																																																																					
01	1 k Ω																																																																																					
05	5 k Ω																																																																																					
10	10 k Ω																																																																																					
	Terminale candela adattabile																																																																																					
E	Per terminale con nottolino o terminale ad ogiva																																																																																					
F	Per terminale filettato																																																																																					
	Colore cappuccio candela																																																																																					
-B	Blu																																																																																					
-G	Verde																																																																																					
-R	Rosso																																																																																					
-Y	Giallo																																																																																					
Nessuno	Nero																																																																																					
	Dimensione filettatura della candela adattabile																																																																																					
B	Filettatura Ø 14 mm																																																																																					
C	Filettatura Ø 10 mm Solo CM-6																																																																																					
D	Filettatura Ø 10 & 12 mm																																																																																					
F	Ø 9 mm																																																																																					
Z	Filettatura Ø 10, 12 & 14 mm																																																																																					
	Accessorio																																																																																					
A, B, D ... e -1, -2, -3 ...	Design speciale																																																																																					
C	Con cavo																																																																																					
F	Per cavo 5 mm Ø																																																																																					
G	Con anello di tenuta in gomma																																																																																					
H	Tipo compatto																																																																																					
K	Con copertura in silicone impermeabile																																																																																					
L	Tipo resistore induttivo																																																																																					
M	Anello di tenuta in gomma																																																																																					
P	Con copertura speciale impermeabile																																																																																					
W	Molle del connettore doppio																																																																																					
Y	Con manico																																																																																					
Z	Forma speciale																																																																																					

PIPAS DE BUJÍA NGK CON RESISTENCIA

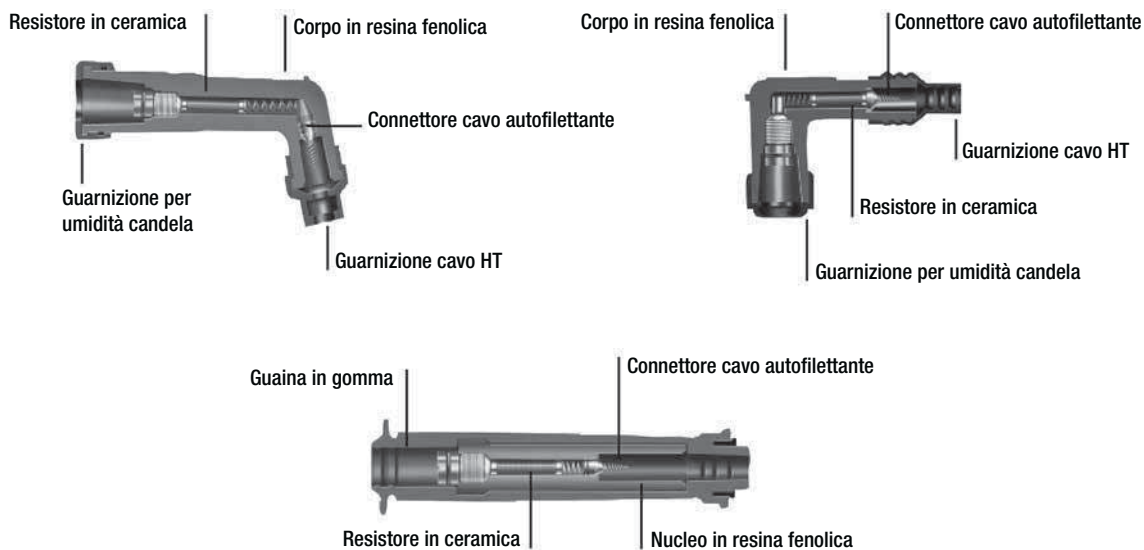
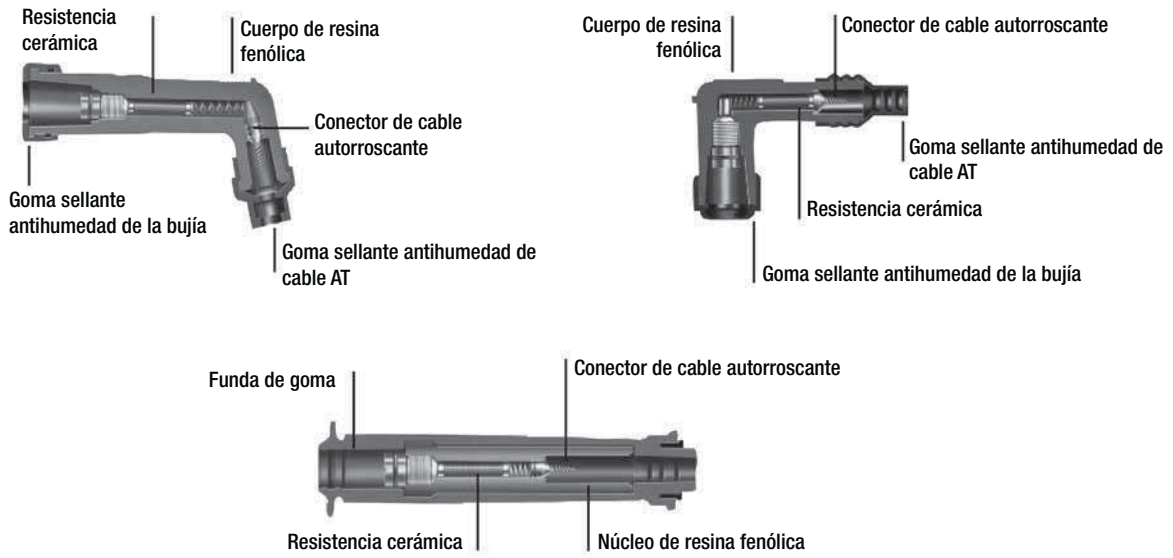

CODIFICACIÓN DE LAS PIPAS

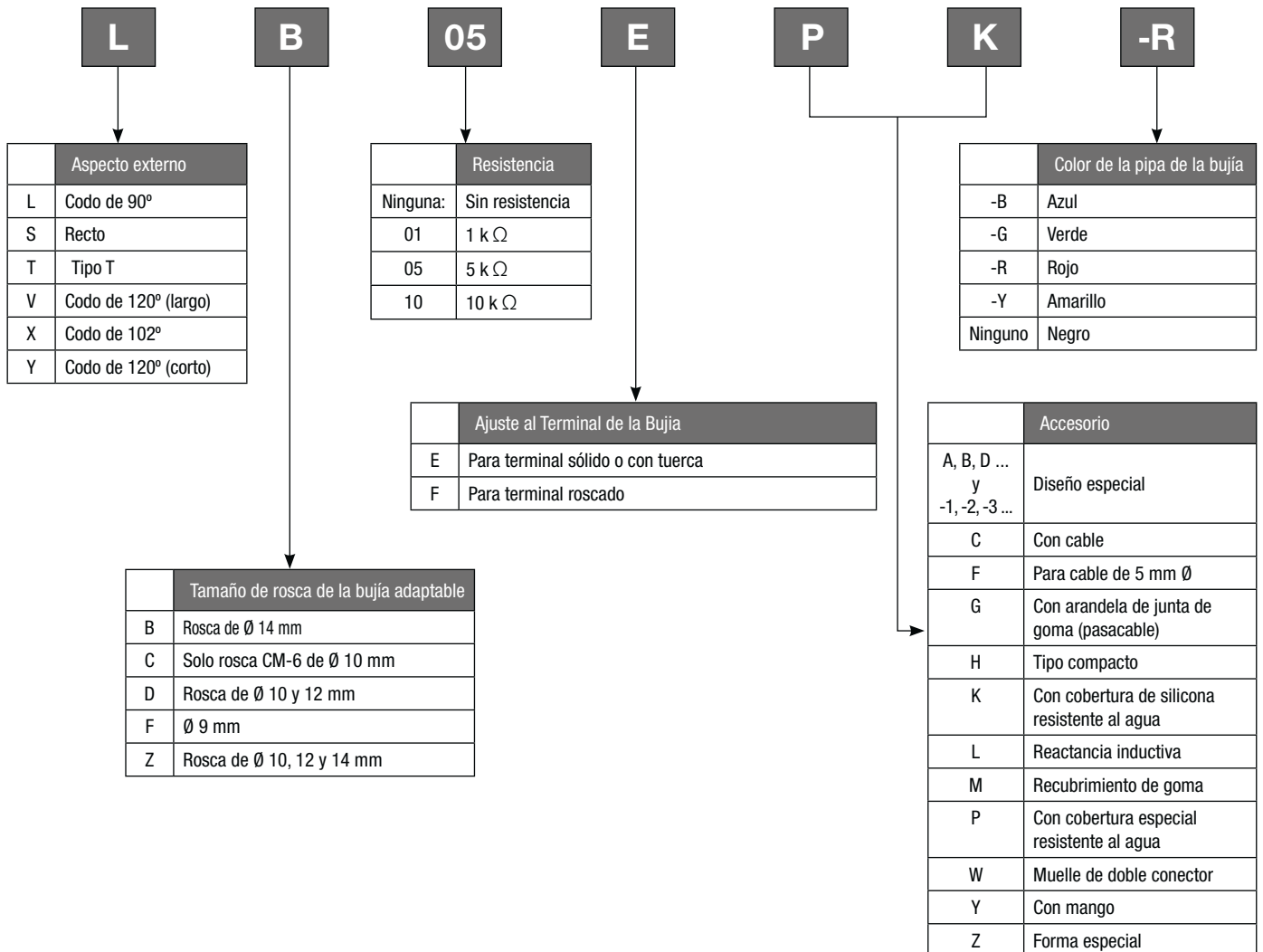

NGK ONTSTOORDE BOUGIE DOP

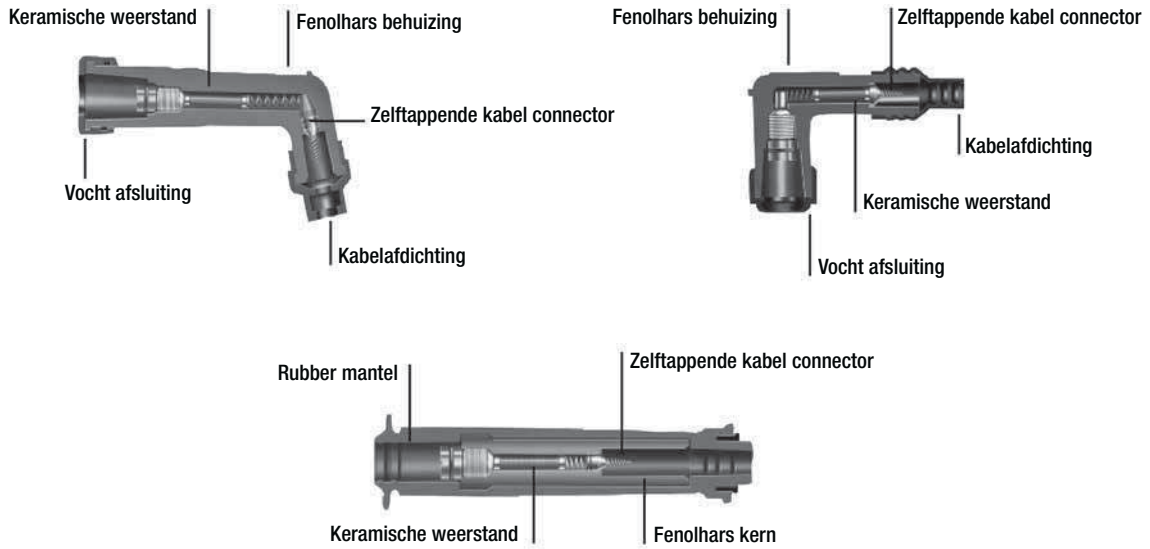

UITLEG MARKERINGSTEKENS

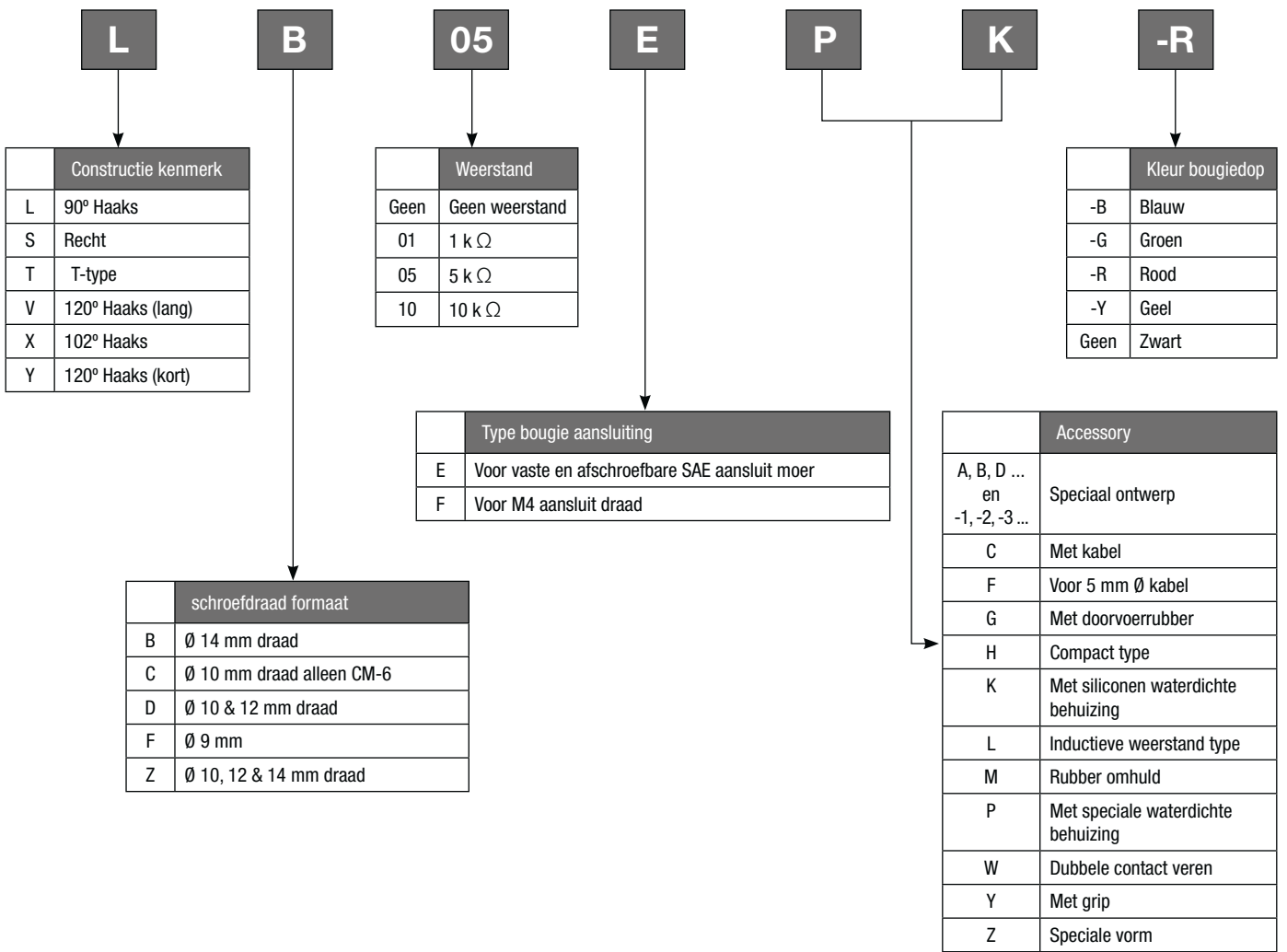

CACHIMBO DE RESISTOR NGK



CODIFICAÇÃO DO CACHIMBO DE RESISTOR

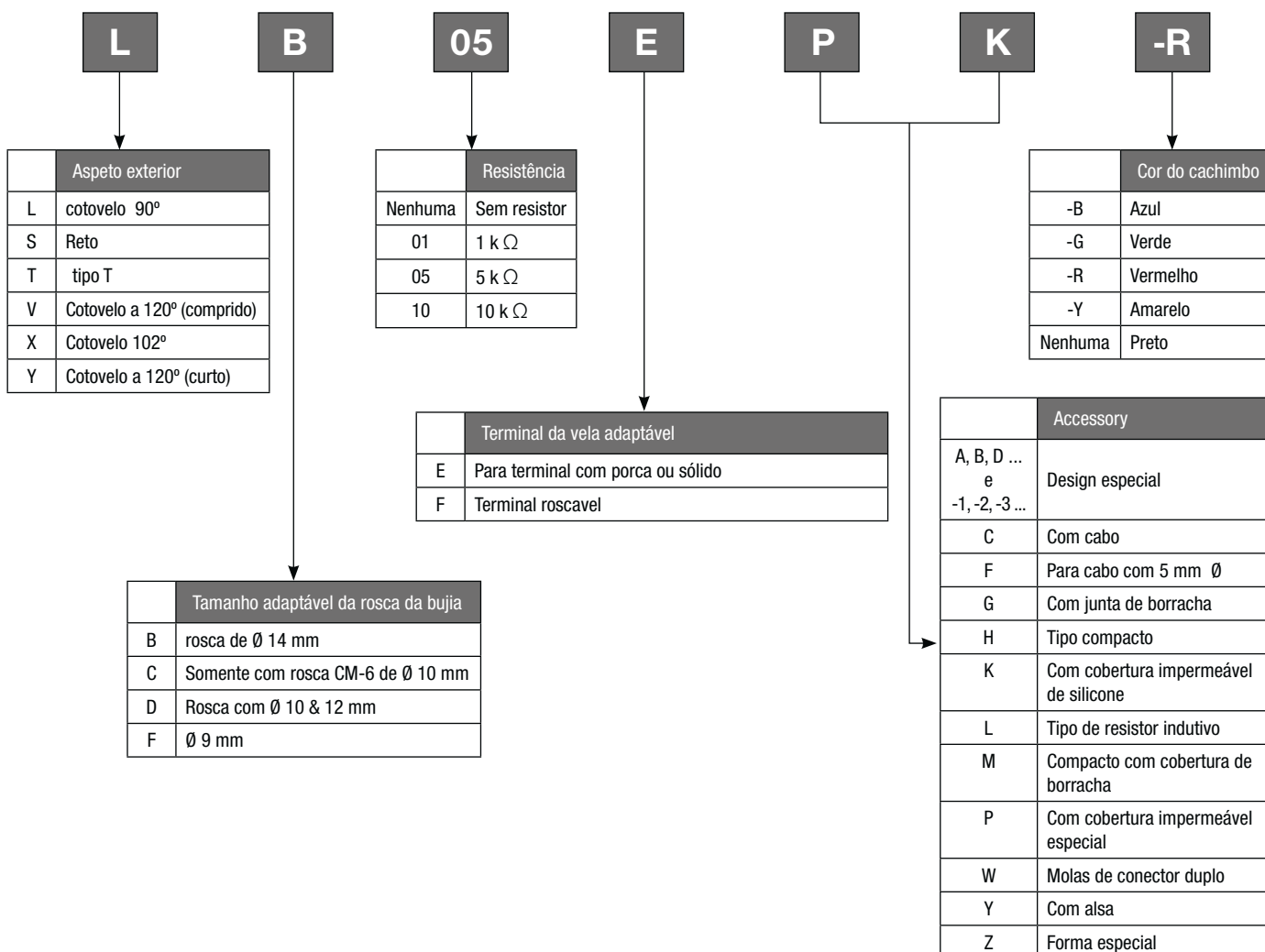

ΑΝΤΙΠΑΡΑΣΙΤΙΚΕΣ ΠΙΠΕΣ NGK

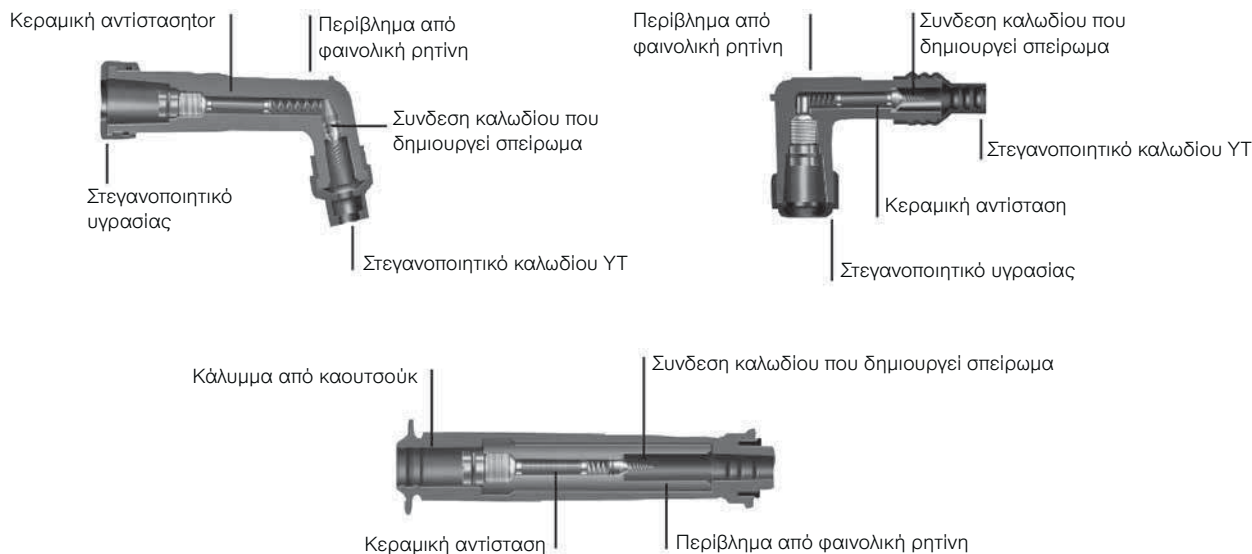

Σχεδιάγραμμα επεξήγησης συμβόλων

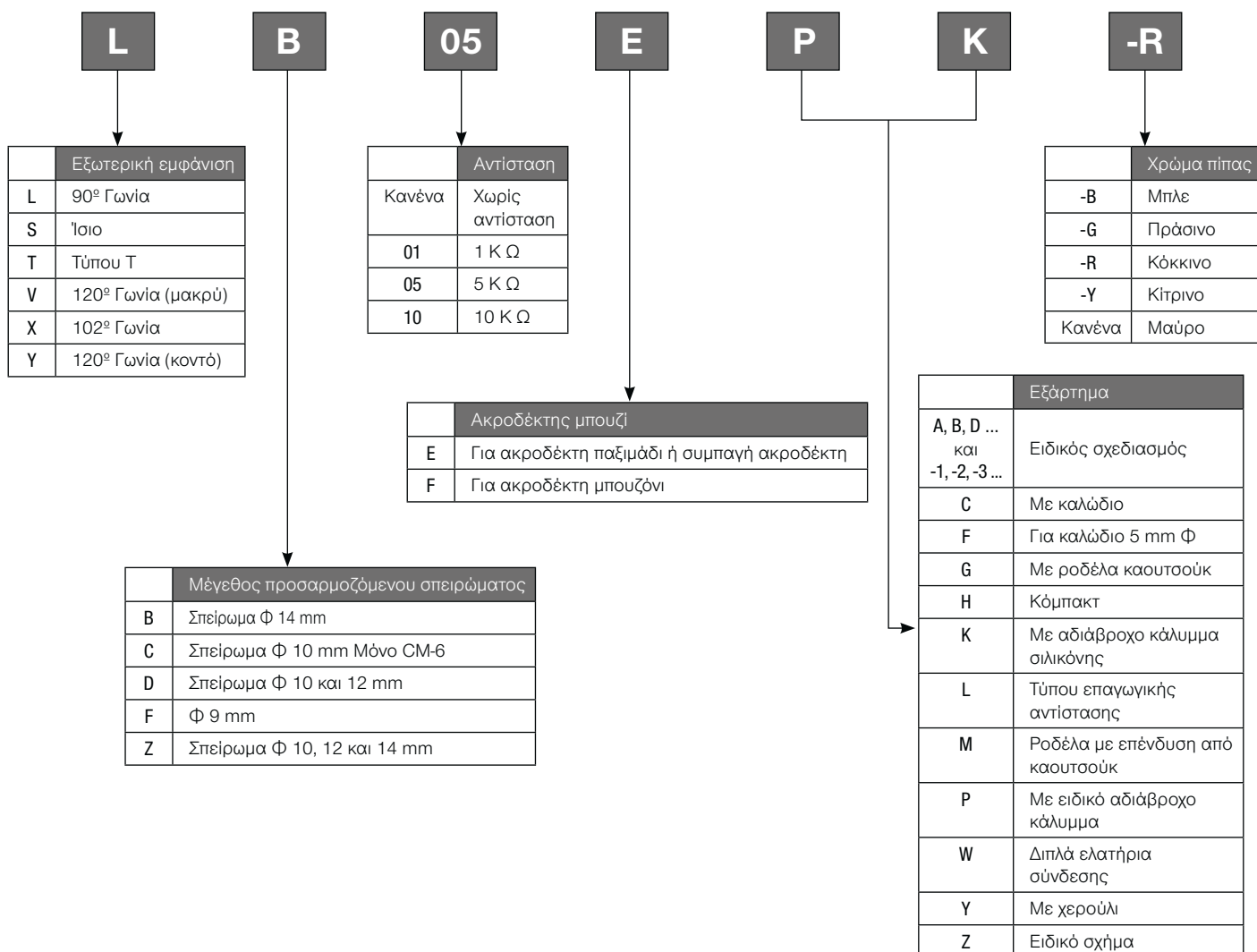

NGK DİRENÇLİ BUJİ BAŞLIKLARI



BUJİ BAŞLIKLARI KOD AÇIKLAMA TABLOSU

L	B	05	E	P	K	-R																																																																															
<table border="1"> <thead> <tr> <th></th> <th>Dış görünüm</th> </tr> </thead> <tbody> <tr> <td>L</td> <td>90° dirsek tip</td> </tr> <tr> <td>S</td> <td>Düz tip</td> </tr> <tr> <td>T</td> <td>T tip</td> </tr> <tr> <td>V</td> <td>120° dirsek tip (uzun)</td> </tr> <tr> <td>X</td> <td>102° dirsek tip</td> </tr> <tr> <td>Y</td> <td>dirsek tip (kısa)</td> </tr> </tbody> </table>		Dış görünüm	L	90° dirsek tip	S	Düz tip	T	T tip	V	120° dirsek tip (uzun)	X	102° dirsek tip	Y	dirsek tip (kısa)	<table border="1"> <thead> <tr> <th></th> <th>Direnç</th> </tr> </thead> <tbody> <tr> <td>Boş</td> <td>/</td> </tr> <tr> <td>01</td> <td>1 kΩ</td> </tr> <tr> <td>05</td> <td>5 kΩ</td> </tr> <tr> <td>10</td> <td>10 kΩ</td> </tr> </tbody> </table>		Direnç	Boş	/	01	1 k Ω	05	5 k Ω	10	10 k Ω	<table border="1"> <thead> <tr> <th></th> <th>Buji başlığı rengi</th> </tr> </thead> <tbody> <tr> <td>-B</td> <td>Mavi</td> </tr> <tr> <td>-G</td> <td>Yeşil</td> </tr> <tr> <td>-R</td> <td>Kırmızı</td> </tr> <tr> <td>-Y</td> <td>Sarı</td> </tr> <tr> <td>Boş</td> <td>Siyah</td> </tr> </tbody> </table>		Buji başlığı rengi	-B	Mavi	-G	Yeşil	-R	Kırmızı	-Y	Sarı	Boş	Siyah	<table border="1"> <thead> <tr> <th></th> <th>Buji soketi</th> </tr> </thead> <tbody> <tr> <td>E</td> <td>Somunlu soket yada sabit başlıklar için</td> </tr> <tr> <td>F</td> <td>Vida dişli soketliler için</td> </tr> </tbody> </table>		Buji soketi	E	Somunlu soket yada sabit başlıklar için	F	Vida dişli soketliler için	<table border="1"> <thead> <tr> <th></th> <th>Aksesuar</th> </tr> </thead> <tbody> <tr> <td>A, B, D ... ve -1, -2, -3 ...</td> <td>Özel tasarım</td> </tr> <tr> <td>C</td> <td>Kablo ile</td> </tr> <tr> <td>F</td> <td>5mm çaplı kablolar için</td> </tr> <tr> <td>G</td> <td>Kauçuk rondelalı</td> </tr> <tr> <td>H</td> <td>Kompact tip</td> </tr> <tr> <td>K</td> <td>Silikon su geçirmez kılıf ile</td> </tr> <tr> <td>L</td> <td>Endükleyci dirençli tip</td> </tr> <tr> <td>M</td> <td>Kauçuk kılıflı</td> </tr> <tr> <td>P</td> <td>Özel su geçirmez kılıf ile</td> </tr> <tr> <td>W</td> <td>Çift bağlantı yaylı</td> </tr> <tr> <td>Y</td> <td>Kulplu</td> </tr> <tr> <td>Z</td> <td>Özel şekil</td> </tr> </tbody> </table>		Aksesuar	A, B, D ... ve -1, -2, -3 ...	Özel tasarım	C	Kablo ile	F	5mm çaplı kablolar için	G	Kauçuk rondelalı	H	Kompact tip	K	Silikon su geçirmez kılıf ile	L	Endükleyci dirençli tip	M	Kauçuk kılıflı	P	Özel su geçirmez kılıf ile	W	Çift bağlantı yaylı	Y	Kulplu	Z	Özel şekil	<table border="1"> <thead> <tr> <th></th> <th>Buji vida dişi ölçüsü</th> </tr> </thead> <tbody> <tr> <td>B</td> <td>14mm vida dişi</td> </tr> <tr> <td>C</td> <td>Sadece CM-6 için 10mm vida dişi</td> </tr> <tr> <td>D</td> <td>Ø 10 & 12 mm vida dişi</td> </tr> <tr> <td>F</td> <td>Ø 9 mm</td> </tr> <tr> <td>Z</td> <td>Ø 10, 12 & 14 mm vida dişi</td> </tr> </tbody> </table>		Buji vida dişi ölçüsü	B	14mm vida dişi	C	Sadece CM-6 için 10mm vida dişi	D	Ø 10 & 12 mm vida dişi	F	Ø 9 mm	Z	Ø 10, 12 & 14 mm vida dişi
	Dış görünüm																																																																																				
L	90° dirsek tip																																																																																				
S	Düz tip																																																																																				
T	T tip																																																																																				
V	120° dirsek tip (uzun)																																																																																				
X	102° dirsek tip																																																																																				
Y	dirsek tip (kısa)																																																																																				
	Direnç																																																																																				
Boş	/																																																																																				
01	1 k Ω																																																																																				
05	5 k Ω																																																																																				
10	10 k Ω																																																																																				
	Buji başlığı rengi																																																																																				
-B	Mavi																																																																																				
-G	Yeşil																																																																																				
-R	Kırmızı																																																																																				
-Y	Sarı																																																																																				
Boş	Siyah																																																																																				
	Buji soketi																																																																																				
E	Somunlu soket yada sabit başlıklar için																																																																																				
F	Vida dişli soketliler için																																																																																				
	Aksesuar																																																																																				
A, B, D ... ve -1, -2, -3 ...	Özel tasarım																																																																																				
C	Kablo ile																																																																																				
F	5mm çaplı kablolar için																																																																																				
G	Kauçuk rondelalı																																																																																				
H	Kompact tip																																																																																				
K	Silikon su geçirmez kılıf ile																																																																																				
L	Endükleyci dirençli tip																																																																																				
M	Kauçuk kılıflı																																																																																				
P	Özel su geçirmez kılıf ile																																																																																				
W	Çift bağlantı yaylı																																																																																				
Y	Kulplu																																																																																				
Z	Özel şekil																																																																																				
	Buji vida dişi ölçüsü																																																																																				
B	14mm vida dişi																																																																																				
C	Sadece CM-6 için 10mm vida dişi																																																																																				
D	Ø 10 & 12 mm vida dişi																																																																																				
F	Ø 9 mm																																																																																				
Z	Ø 10, 12 & 14 mm vida dişi																																																																																				

FAJKI DO ŚWIEC ZAPŁONOWYCH



OZNAKOWANIE FAJK DO ŚWIEC ZAPŁONOWYCH

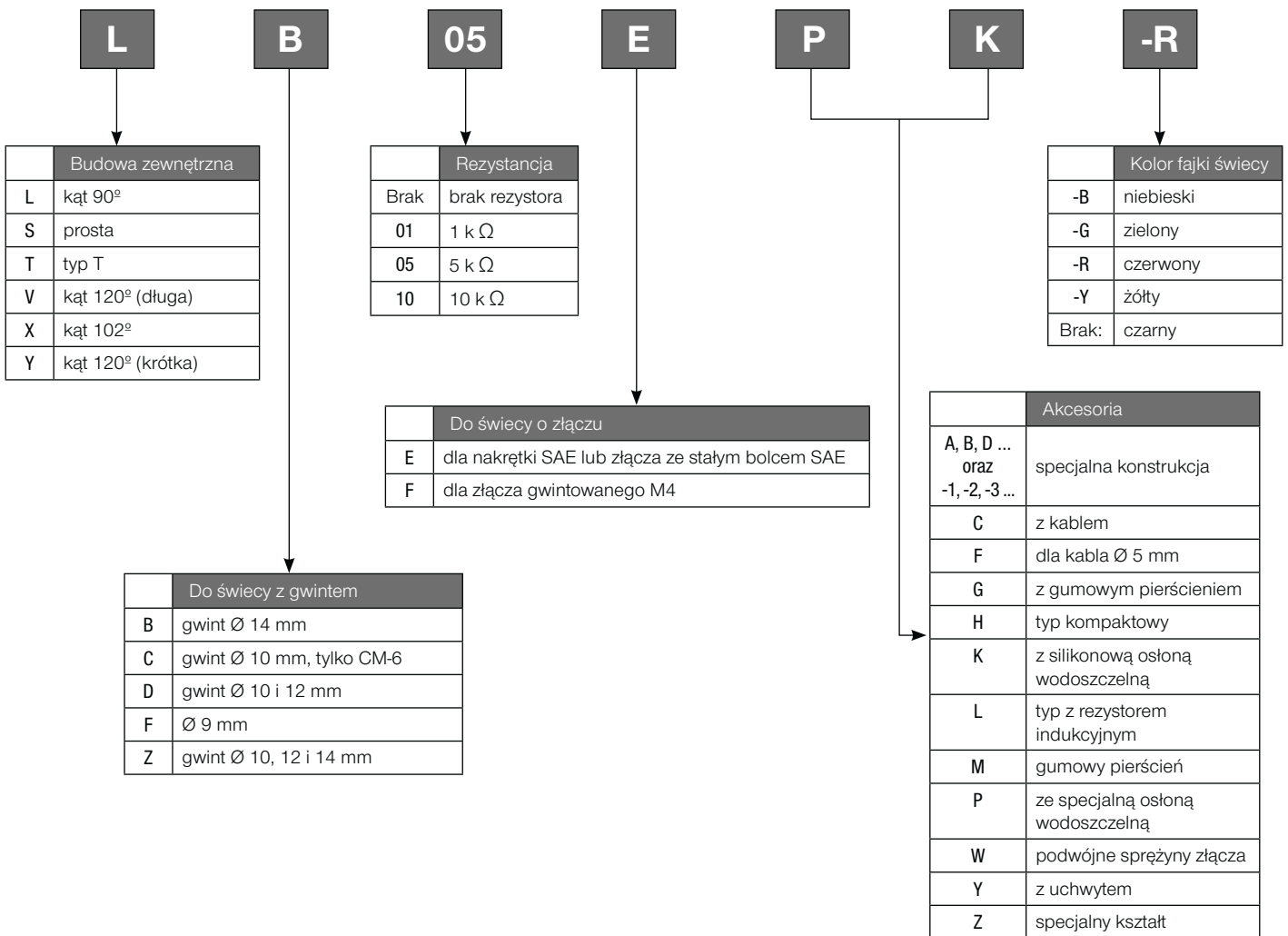

NGK RESISTOR PLUG COVERS

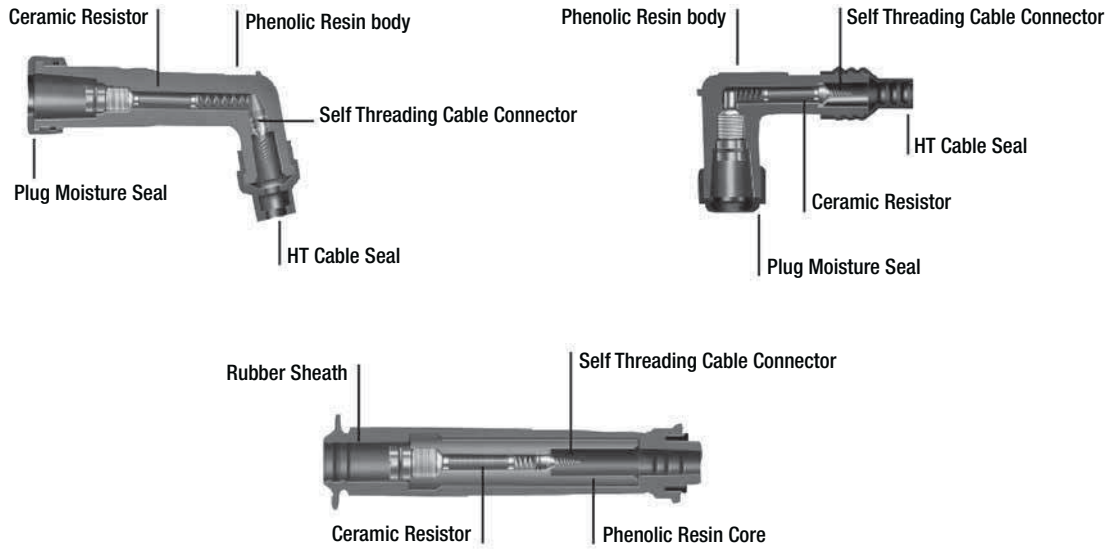

COVER SYMBOLS EXPLANATION CHART

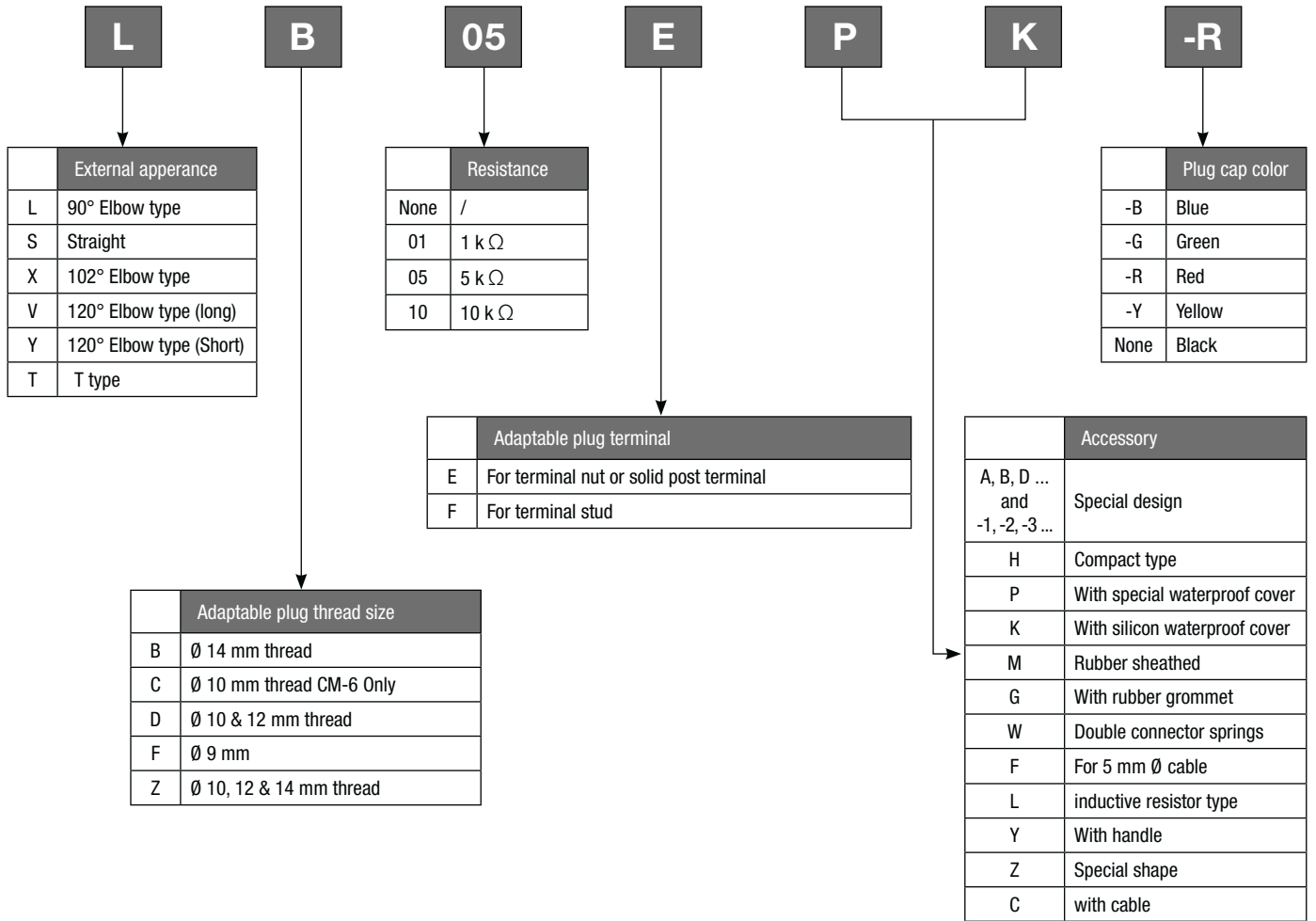

NGK ELLENÁLLÁS GYERTYAPIPÁK

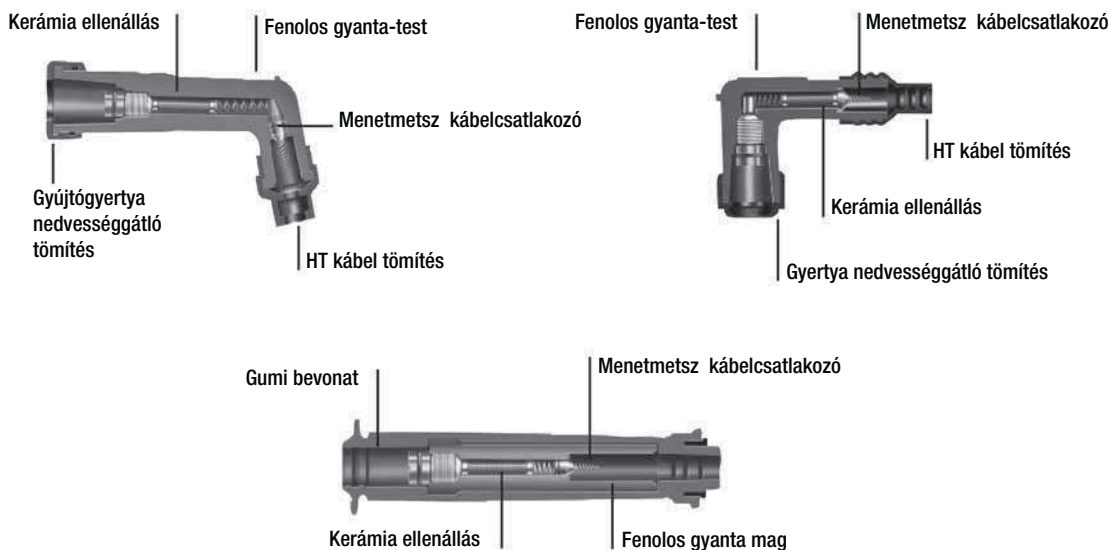

TÁBLÁZAT SZIGNIFIKANCIA KÓD





L	B	05	E	P	K	-R																																																																													
<table border="1"> <thead> <tr> <th></th> <th>Küls megjelenés</th> </tr> </thead> <tbody> <tr> <td>L</td> <td>90°-os könyök típus</td> </tr> <tr> <td>S</td> <td>Egyenes</td> </tr> <tr> <td>T</td> <td>T típus</td> </tr> <tr> <td>V</td> <td>120°-os könyök típus (hosszú)</td> </tr> <tr> <td>X</td> <td>102°-os könyök típus</td> </tr> <tr> <td>Y</td> <td>120°-os könyök típus (rövid)</td> </tr> </tbody> </table>		Küls megjelenés	L	90°-os könyök típus	S	Egyenes	T	T típus	V	120°-os könyök típus (hosszú)	X	102°-os könyök típus	Y	120°-os könyök típus (rövid)	<table border="1"> <thead> <tr> <th></th> <th>Ellenállás</th> </tr> </thead> <tbody> <tr> <td>Egyik sem</td> <td>Nincs ellenállás</td> </tr> <tr> <td>01</td> <td>1 k Ω</td> </tr> <tr> <td>05</td> <td>5 k Ω</td> </tr> <tr> <td>10</td> <td>10 k Ω</td> </tr> </tbody> </table>		Ellenállás	Egyik sem	Nincs ellenállás	01	1 k Ω	05	5 k Ω	10	10 k Ω	<table border="1"> <thead> <tr> <th></th> <th>Gyertyapipa színe</th> </tr> </thead> <tbody> <tr> <td>-B</td> <td>Kék</td> </tr> <tr> <td>-G</td> <td>Zöld</td> </tr> <tr> <td>-R</td> <td>Piros</td> </tr> <tr> <td>-Y</td> <td>Sárga</td> </tr> <tr> <td>Egyik sem</td> <td>Fekete</td> </tr> </tbody> </table>		Gyertyapipa színe	-B	Kék	-G	Zöld	-R	Piros	-Y	Sárga	Egyik sem	Fekete	<table border="1"> <thead> <tr> <th></th> <th>Csatlakozás</th> </tr> </thead> <tbody> <tr> <td>E</td> <td>Anyacsavarhoz vagy a tömör csatlakozóvéghez</td> </tr> <tr> <td>F</td> <td>Biztosítókapocshoz</td> </tr> </tbody> </table>		Csatlakozás	E	Anyacsavarhoz vagy a tömör csatlakozóvéghez	F	Biztosítókapocshoz	<table border="1"> <thead> <tr> <th></th> <th>Accessory</th> </tr> </thead> <tbody> <tr> <td>A, B, D ... és -1, -2, -3 ...</td> <td>Speciális kialakítás</td> </tr> <tr> <td>C</td> <td>Kábelrel</td> </tr> <tr> <td>F</td> <td>5 mm-es Ø kábelhez</td> </tr> <tr> <td>G</td> <td>Gumitömítéssel</td> </tr> <tr> <td>H</td> <td>Kompakt</td> </tr> <tr> <td>K</td> <td>Szilikon vízálló kupakkal</td> </tr> <tr> <td>L</td> <td>Induktív ellenállás típus</td> </tr> <tr> <td>M</td> <td>Gumitömítés</td> </tr> <tr> <td>P</td> <td>Speciális vízálló kupakkal</td> </tr> <tr> <td>W</td> <td>Dupla csatlakozó rugó</td> </tr> <tr> <td>Y</td> <td>Fogantyúval</td> </tr> <tr> <td>Z</td> <td>Különleges alak</td> </tr> </tbody> </table>		Accessory	A, B, D ... és -1, -2, -3 ...	Speciális kialakítás	C	Kábelrel	F	5 mm-es Ø kábelhez	G	Gumitömítéssel	H	Kompakt	K	Szilikon vízálló kupakkal	L	Induktív ellenállás típus	M	Gumitömítés	P	Speciális vízálló kupakkal	W	Dupla csatlakozó rugó	Y	Fogantyúval	Z	Különleges alak	<table border="1"> <thead> <tr> <th></th> <th>Csatlakoztatható gyertyamenet méret</th> </tr> </thead> <tbody> <tr> <td>B</td> <td>Ø 14 mm-es menet</td> </tr> <tr> <td>C</td> <td>Ø 10 mm-es menet Csak CM-6</td> </tr> <tr> <td>D</td> <td>Ø 10 és 12 mm-es menetek</td> </tr> <tr> <td>F</td> <td>Ø 9 mm</td> </tr> </tbody> </table>		Csatlakoztatható gyertyamenet méret	B	Ø 14 mm-es menet	C	Ø 10 mm-es menet Csak CM-6	D	Ø 10 és 12 mm-es menetek	F	Ø 9 mm
	Küls megjelenés																																																																																		
L	90°-os könyök típus																																																																																		
S	Egyenes																																																																																		
T	T típus																																																																																		
V	120°-os könyök típus (hosszú)																																																																																		
X	102°-os könyök típus																																																																																		
Y	120°-os könyök típus (rövid)																																																																																		
	Ellenállás																																																																																		
Egyik sem	Nincs ellenállás																																																																																		
01	1 k Ω																																																																																		
05	5 k Ω																																																																																		
10	10 k Ω																																																																																		
	Gyertyapipa színe																																																																																		
-B	Kék																																																																																		
-G	Zöld																																																																																		
-R	Piros																																																																																		
-Y	Sárga																																																																																		
Egyik sem	Fekete																																																																																		
	Csatlakozás																																																																																		
E	Anyacsavarhoz vagy a tömör csatlakozóvéghez																																																																																		
F	Biztosítókapocshoz																																																																																		
	Accessory																																																																																		
A, B, D ... és -1, -2, -3 ...	Speciális kialakítás																																																																																		
C	Kábelrel																																																																																		
F	5 mm-es Ø kábelhez																																																																																		
G	Gumitömítéssel																																																																																		
H	Kompakt																																																																																		
K	Szilikon vízálló kupakkal																																																																																		
L	Induktív ellenállás típus																																																																																		
M	Gumitömítés																																																																																		
P	Speciális vízálló kupakkal																																																																																		
W	Dupla csatlakozó rugó																																																																																		
Y	Fogantyúval																																																																																		
Z	Különleges alak																																																																																		
	Csatlakoztatható gyertyamenet méret																																																																																		
B	Ø 14 mm-es menet																																																																																		
C	Ø 10 mm-es menet Csak CM-6																																																																																		
D	Ø 10 és 12 mm-es menetek																																																																																		
F	Ø 9 mm																																																																																		

КОЛПАЧКИ ДЛЯ СВЕЧЕЙ ЗАЖИГАНИЯ С РЕЗИСТОРОМ NGK

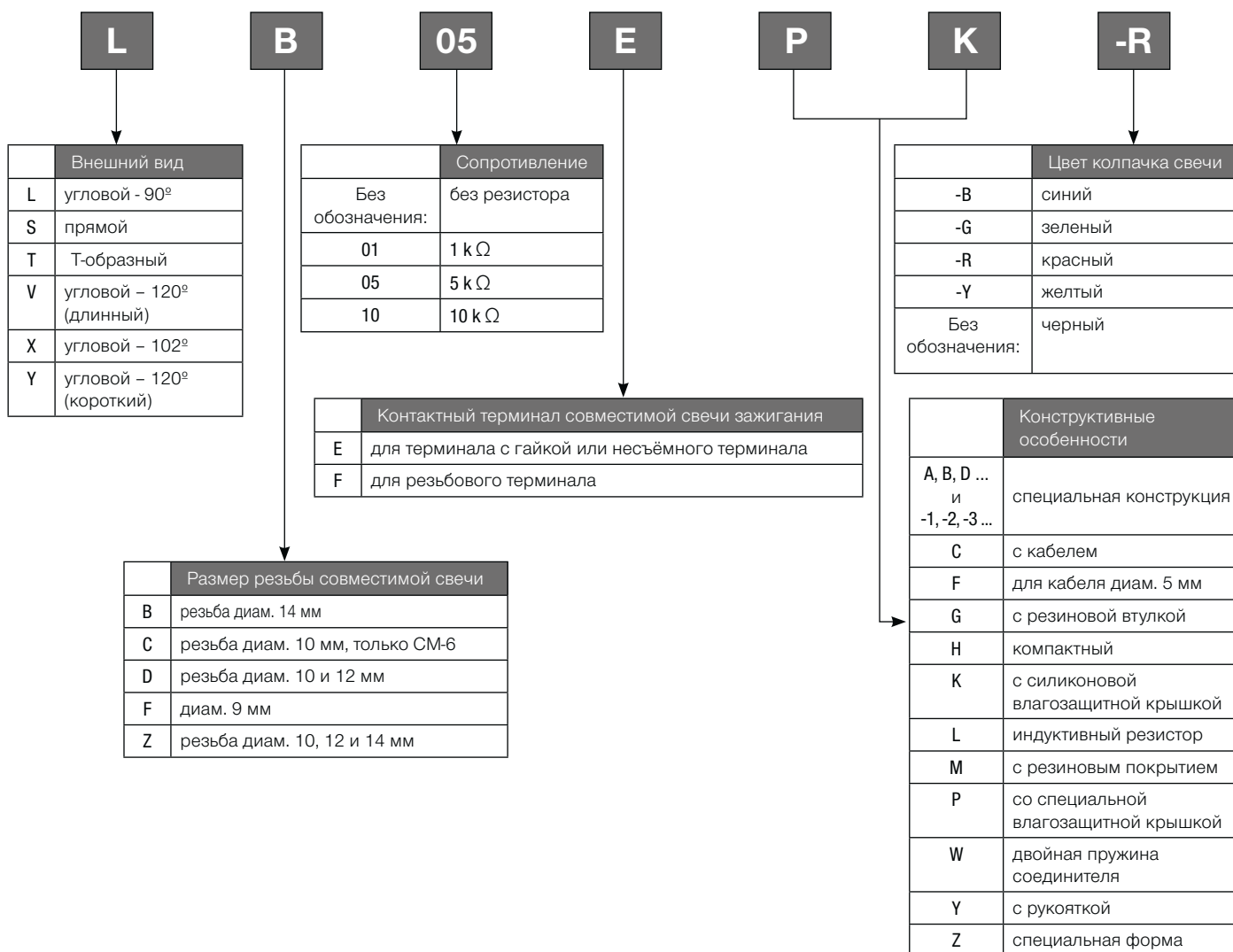



РАСШИФРОВКА МАРКИРОВКИ



Basic	Type	Stock-No.	Colour	R [kΩ]	Ø [mm]	Terminal
LB	LB - E	8302	black	/	14	
	LB01E	8011	black	1		
	LB05E - R	8898	red	5		
	LB05E	8031	black	5		
	LB10E	8349	black	10		
	LB - F	8309	black	/		
	LB01F	8330	black	1		
	LB01FF	8331	black	1		
	LB05F	8051	black	5		
	LB05F - R	8854	red	5		
	LB05FF	30326	black	5		
	LB10F	8358	black	10		
	LB10FF	8359	black	10		
LD	LD05E	6902	black	5	10-12	
	LD05EH	92248	black	5		
	LD - F	8311	black	/		
	LD01F	8362	black	1		
	LD05F - R	8231	red	5		
	LD05F	8060	black	5		
	LD10F	8997	black	10		

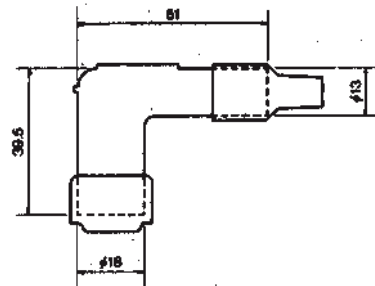

Phenolic Resin





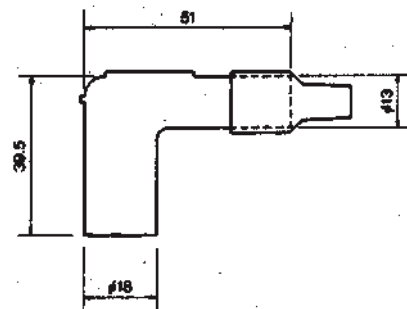

Basic	Type	Stock-No.	Colour	R [kΩ]	Ø [mm]	Terminal
LB	LB01EP	8328	black	1	14	
	LB05EP	8020	black	5		
	LB - EPK	8304	black	/		
	LB05EPK	8342	black	5		
	LB01FP	8088	black	1		
	LB05FP	8030	black	5		
LD	LD05FP	8070	black	5	10 - 12	



Phenolic Resin

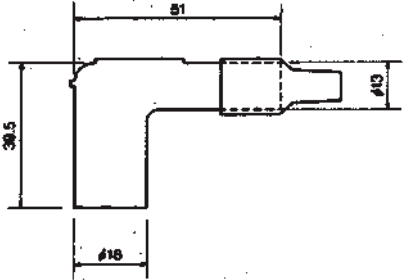



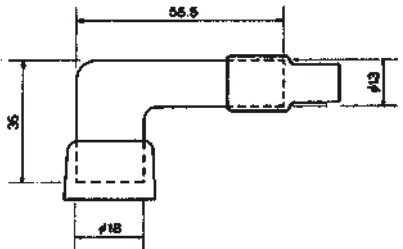

Basic	Type	Stock-No.	Colour	R [kΩ]	Ø [mm]	Terminal
LZ	LZ05F	8368	black	5	10-12-14	
Phenolic Resin 						

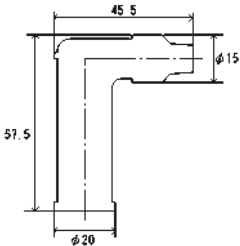

Basic	Type	Stock-No.	Colour	R [kΩ]	Ø [mm]	Terminal
LB	LB05FG	8346	black	5	14	
Phenolic Resin  						

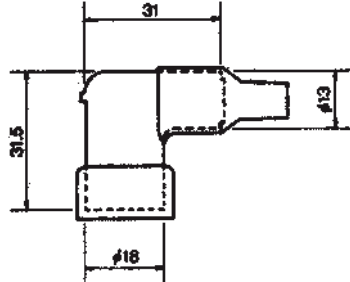

Basic	Type	Stock-No.	Colour	R [kΩ]	Ø [mm]	Terminal
LB	LB05EZ	8744	black	5	14	
Phenolic Resin  						

Basic	Type	Stock-No.	Colour	R [kΩ]	Ø [mm]	Terminal
L	L05EA	6667	black	5		
Phenolic Resin  						

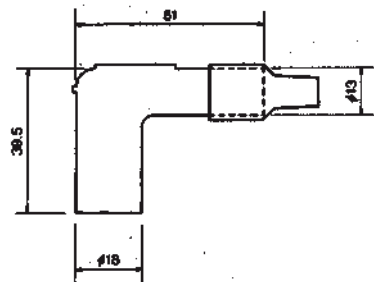

Basic	Type	Stock-No.	Colour	R [kΩ]	Ø [mm]	Terminal
L	L - EH	8301	black	/		
Phenolic Resin						
						

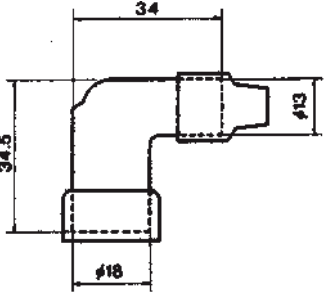

Basic	Type	Stock-No.	Colour	R [kΩ]	Ø [mm]	Terminal
LB	LB01EH	8326	black	1	14	
	LB01EHF	8327	black	1		
	LB05EH	8334	black	5		
	LB05EHF	8336	black	5		
	LB10EH	8351	black	10		
	LB10EHF	8055	black	10		
LD	LD - FH	8310	black	/	10-12	
	LD - FH	8313	black	/		
Phenolic Resin						
 						

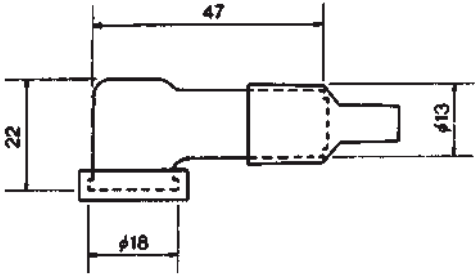

Basic	Type	Stock-No.	Colour	R [kΩ]	Ø [mm]	Terminal
LB	LB10EHAk	8719	black	10	14	
Phenolic Resin						
 						

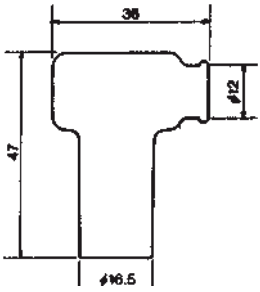

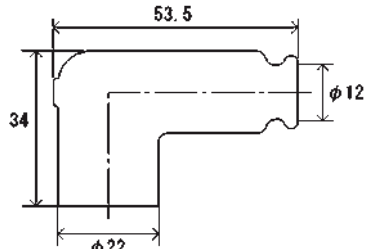

Basic	Type	Stock-No.	Colour	R [kΩ]	Ø [mm]	Terminal
LZ	LZEH	8760	black	/	10-12-14	
	LZFH	8710	black	/		
Phenolic Resin  						

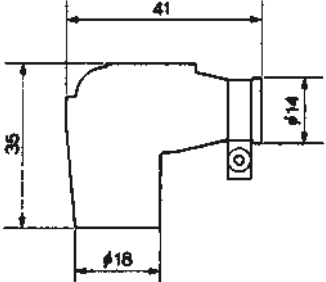

Basic	Type	Stock-No.	Colour	R [kΩ]	Ø [mm]	Terminal
LC	LC05EFK	8050	black	5	CM6	
Phenolic Resin  						



Basic	Type	Stock-No.	Colour	R [kΩ]	Ø [mm]	Terminal
LB	LB05EMH	8338	black	5	14	
	LB05EMH - R	8160	red	5		
Rubber sheated  						

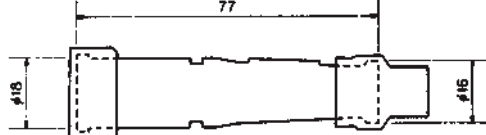

Basic	Type	Stock-No.	Colour	R [kΩ]	Ø [mm]	Terminal
LB	LB05EMHA	8549	red	5	14	
<p>Rubber sheated</p>  						



Basic	Type	Stock-No.	Colour	R [kΩ]	Ø [mm]	Terminal
LB	LBER - B	8308	blue	/	14	
<p>Silikon Rubber</p>  						

Basic	Type	Stock-No.	Colour	R [kΩ]	Ø [mm]	Terminal
SB	SB01E	8370	black	1	14	
	SB05E	8374	black	5		
	SB10E	8803	black	10		
	SB01F	8372	black	1		
	SB05F	8080	black	5		
	SB05F - R	8567	red	5		
	SB10F	8387	black	10		
SD	SD05E	6894	black	5	10-12	
	SD01F	8388	black	1		
	SD05F	8022	black	5		
	SD05F - R	8238	red	5		
	SD10F	8394	black	10		
SZ	SZ05F	8396	black	5	10-12-14	
<p>Phenolic Resin</p>  						

Basic	Type	Stock-No.	Colour	R [kΩ]	Ø [mm]	Terminal
SB	SB05FP	8386	black	5	14	
SD	SD05FP	8325	black	5	10 - 12	
Phenolic Resin						
						

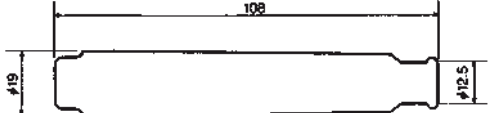
Basic	Type	Stock-No.	Colour	R [kΩ]	Ø [mm]	Terminal
SD	SD05EG	5818	black	5	10-12	
SF	SF05EGK	95554	black	5	9	
Phenolic Resin						
						

Basic	Type	Stock-No.	Colour	R [kΩ]	Ø [mm]	Terminal
SD	SD05FM	8392	black	5	10-12	
	SD05FM - R	8673	red	5		
	SD05EM	92549	black	5		
Rubber sheathed						
 						

Basic	Type	Stock-No.	Colour	R [kΩ]	Ø [mm]	Terminal
SD	SD05FGA	8683	black	5	10-12	
Phenolic Resin						
						
<p>Application: Honda VT 600, XL 600</p>						

Basic	Type	Stock-No.	Colour	R [kΩ]	Ø [mm]	Terminal
VB	VB01E	8405	black	1	14	
	VB05E	8408	black	5		
	VB - F	8913	black	/		
	VB01F	8406	black	1		
	VB05F	8032	black	5		
	VB05F - R	8759	red	5		
	VB10F	8414	black	10		
VD	VD01F	8415	black	1	10-12	
	VD05F	8052	black	5		
	VD05F - R	8376	red	5		
	VD10F	8430	black	10		

Phenolic Resin

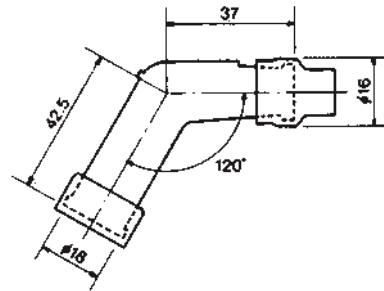

Basic	Type	Stock-No.	Colour	R [kΩ]	Ø [mm]	Terminal
VB	VB05FP	8413	black	5	14	



Phenolic Resin





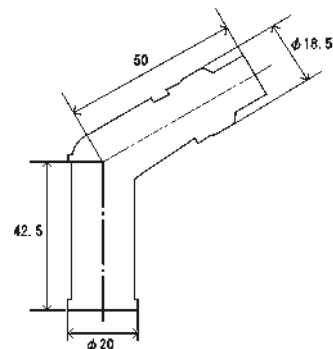

Basic	Type	Stock-No.	Colour	R [kΩ]	Ø [mm]	Terminal
V	V05E	6665	black	5		



Phenolic Resin

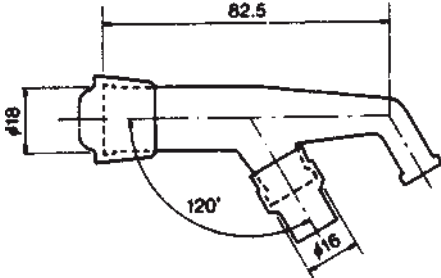



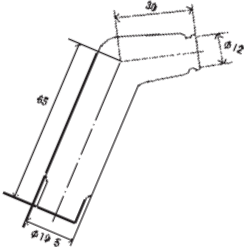

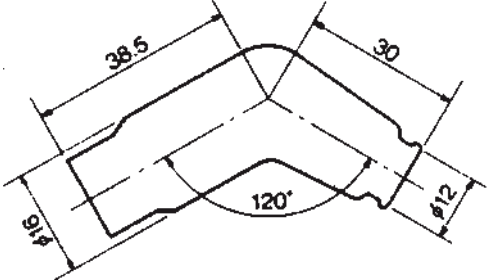

Basic	Type	Stock-No.	Colour	R [kΩ]	Ø [mm]	Terminal
VD	VD05EG	5817	black	5	10-12	
VF	VF05EGAK	92755	black	5	9	
Phenolic Resin						
						



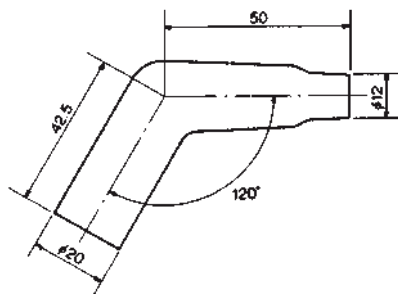

Basic	Type	Stock-No.	Colour	R [kΩ]	Ø [mm]	Terminal
VB	VB05EYK	8411	black	5	14	
Phenolic Resin						
 						

Basic	Type	Stock-No.	Colour	R [kΩ]	Ø [mm]	Terminal
VD	VD05EM	8422	black	5	10-12	
VF	VF05EMK	92648	black	5	9	
Rubber sheathed						
 						

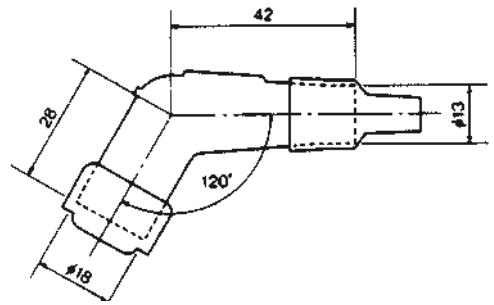
Basic	Type	Stock-No.	Colour	R [kΩ]	Ø [mm]	Terminal
VD	VD05EMH	7744	black	5	10-12	
	VD05FMH	8425	black	5		
Rubber sheathed						
 						

Basic	Type	Stock-No.	Colour	R [kΩ]	Ø [mm]	Terminal
VD	VD05FML	8427	black	5	10-12	
Rubber sheathed						
						

Basic	Type	Stock-No.	Colour	R [kΩ]	Ø [mm]	Terminal
YB	YB01F	8446	black	1	14	
	YB05F	8082	black	5		
	YB05F	8162	red	5		
	YB10F	8449	black	10		
YD	YD01F	8450	black	1	10-12	
	YD05F	8454	black	5		
	YD05F	8453	red	5		
Phenolic Resin						
						

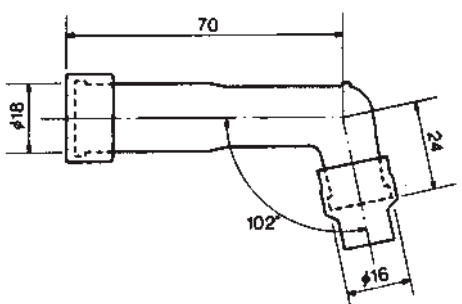
Basic	Type	Stock-No.	Colour	R [kΩ]	Ø [mm]	Terminal
XB	XB01F	8431	black	1	14	
	XB05F	8062	black	5		
	XB05F - R	8592	red	5		
	XB10F	8436	black	10		
XD	XD01F	8439	black	1	10-12	
	XD05F	8072	black	5		
	XD05F - R	8768	red	5		
	XD10F	8442	black	10		
XZ	XZ01F	8443	black	1	10-12-14	
	XZ05F	8444	black	5		
Phenolic Resin						
						

Basic	Type	Stock-No.	Colour	R [kΩ]	Ø [mm]	Terminal
XB	XB05FP	8435	black	5	14	
XD	XD05FP	8641	black	5	10 - 12	

Phenolic Resin



Basic	Type	Stock-No.	Colour	R [kΩ]	Ø [mm]	Terminal
TB	TB05EM - R	8955	red	5	14	
	TB10EM - Y	8404	yellow	10		

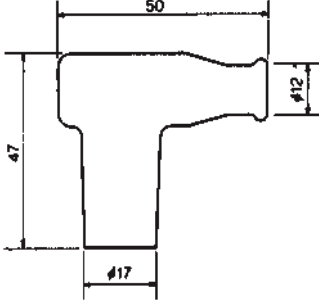

Rubber sheated





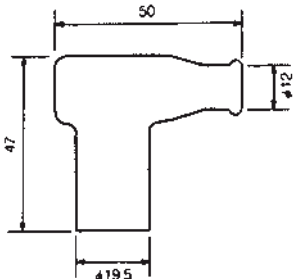

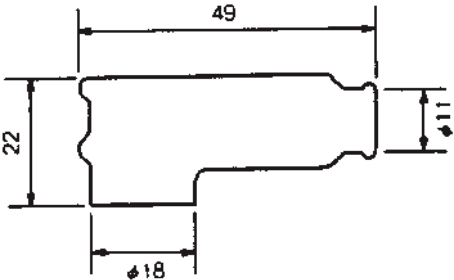

Basic	Type	Stock-No.	Colour	R [kΩ]	Ø [mm]	Terminal
TB	TB05EMA	8636	black	5	14	

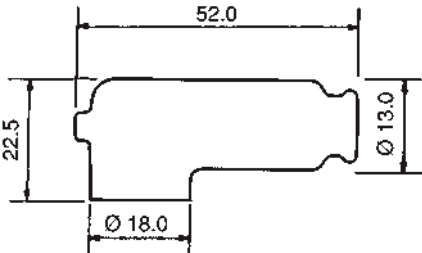

Rubber sheated



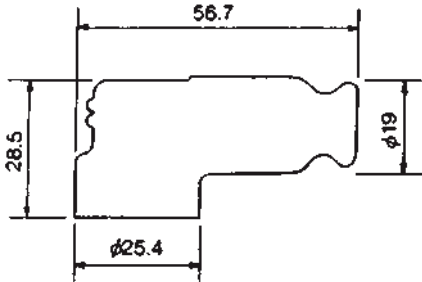

Basic	Type	Stock-No.	Colour	R [kΩ]		Terminal
TB	TRS1225 - B	8787	blue	5	R6120 A/C/M R7282 A/C/M	
<p>Rubber sheathed</p>  						

Basic	Type	Stock-No.	Colour	R [kΩ]		Terminal
TB	TRS1233A - R	8929	red	5	R6120 A/C/M R7282 A/C/M	
	TRS1233B - Y	8897	yellow	5		
	TRS1233C - G	8546	green	5		
<p>Rubber sheathed</p>  						

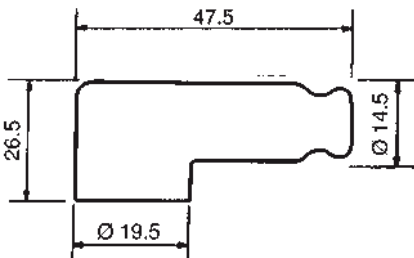
Basic	Type	Stock-No.	Colour	R [kΩ]		Terminal
TB	TRS1408F - B	8871	blue	5	R5300A R5300N	
<p>Rubber sheathed</p>  						



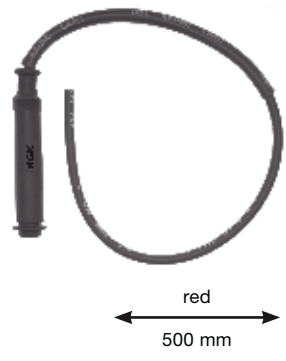
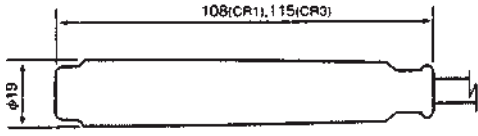

Basic	Type	Stock-No.	Colour	R [kΩ]		Terminal
TB	TRS1409 - R	8733	red	5	R5540F	
<p>Rubber sheathed</p>  						

Basic	Type	Stock-No.	Colour	R [kΩ]	Ø [mm]	Terminal
CR	CR1	8035	red	5	10-12-14	
	CR3	8089	red	5		

Rubber sheathed

CR1: SD05FM CR3: SD05EMK

Basic	Type	Stock-No.	Colour	R [kΩ]	Ø [mm]	Terminal
CR	CR2	8048	red	5	10-12-14	
	CR4	8054	red	5		
	CR5	8515	red	5		
	CR6	8736	red	5		

Rubber sheathed

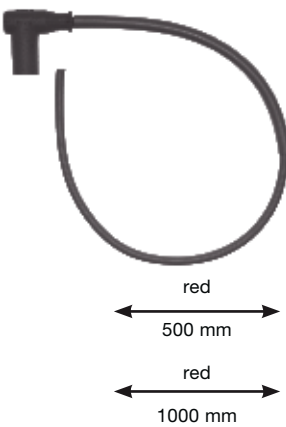
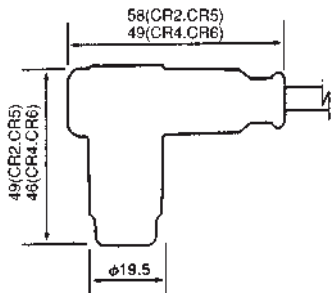

CR2: LZ05FM CR4: TB05EMA
CR5: LZ05FM CR6: TB05EMA



Basic	Type	Stock-No.	Colour	R [kΩ]	Ø [mm]	Terminal
	LY11	8718	red	5	10-12-14	

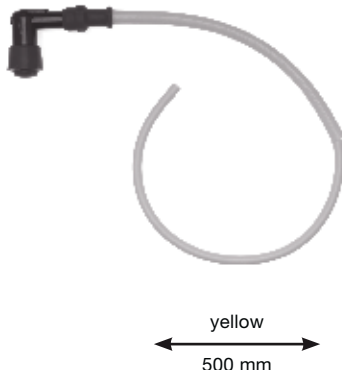
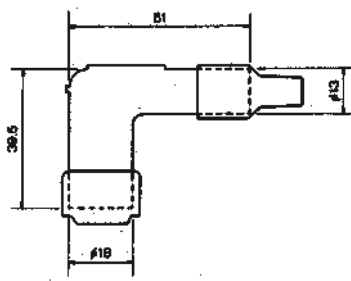

Phenolic Resin





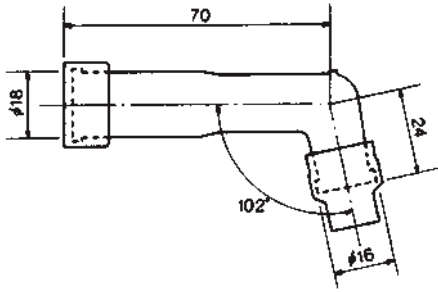

LZ05F

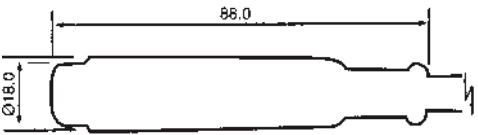
Basic	Type	Stock-No.	Colour	R [kΩ]	Ø [mm]	Terminal
	SY11	8539	red	5	10-12-14	
Phenolic Resin						
					SZ05F	
<p style="text-align: center;">yellow ↔ 500 mm</p>						

Basic	Type	Stock-No.	Colour	R [kΩ]	Ø [mm]	Terminal
	XY11	8584	red	5	10-12-14	
Phenolic Resin						
					XZ05F	
<p style="text-align: center;">yellow ↔ 500 mm</p>						

Basic	Type	Stock-No.	Colour	R [kΩ]	Ø [mm]	Terminal
	SD05FMC	8393	black	5	10-12	
Rubber sheathed						
					SD05FMC	
<p style="text-align: center;">red ↔ 500 mm</p>						

Basic	Type	Stock-No.	Colour	R [kΩ]	Ø [mm]	Terminal
	RC-X140	5937	black	5	10-12	
<p>Phenolic Resin</p>  <p style="text-align: center;">black 350 mm</p> <p style="text-align: right;">LD05EAK</p>						

Basic	Type	Stock-No.	Colour	R [kΩ]	Ø [mm]	Terminal
	J-1	8739	black	/		
						



VEHICLE
ELECTRONICS

NTK OXYGEN SENSORS

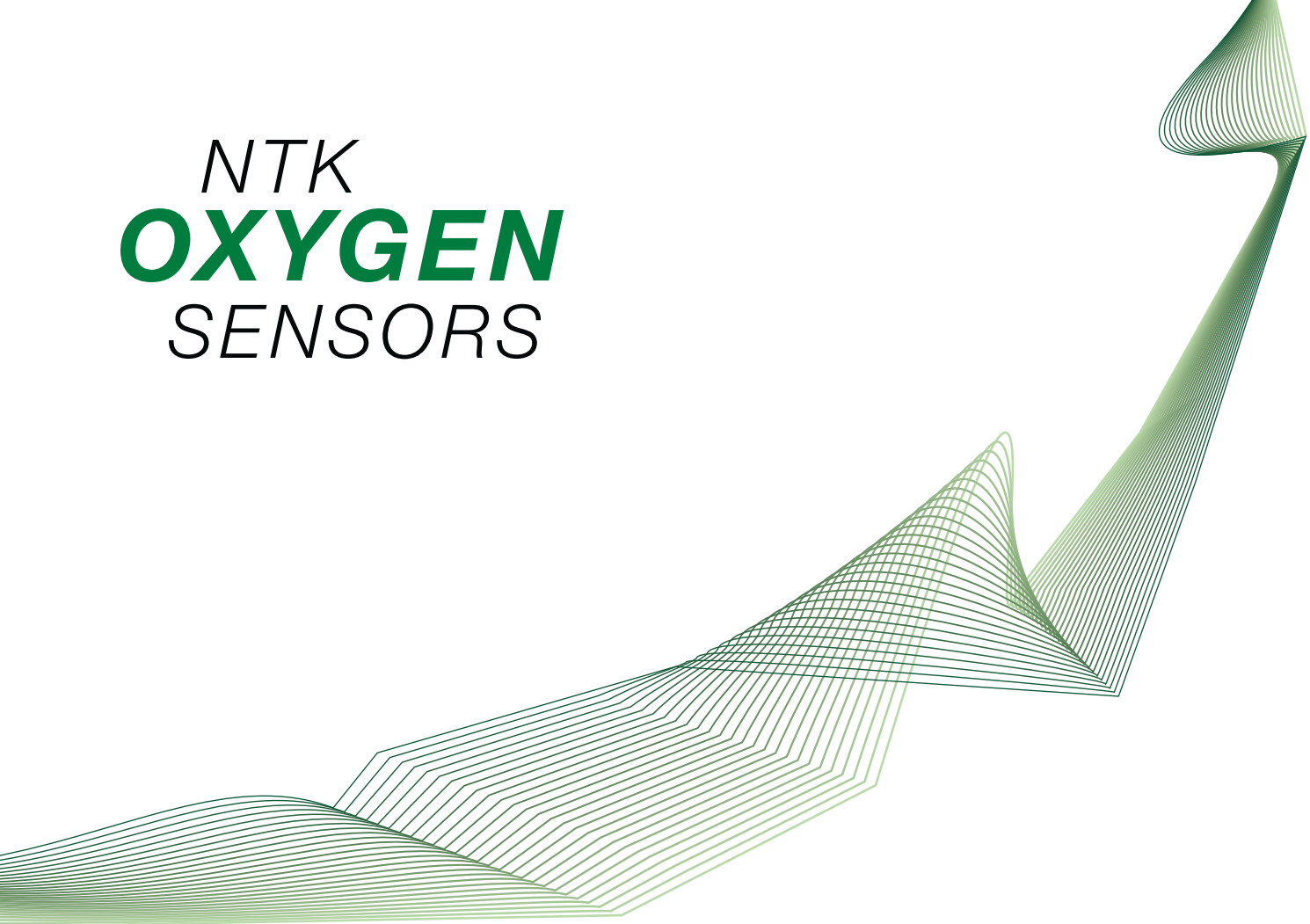

🇬🇧 GB // How to read our part number: Oxygen Sensors

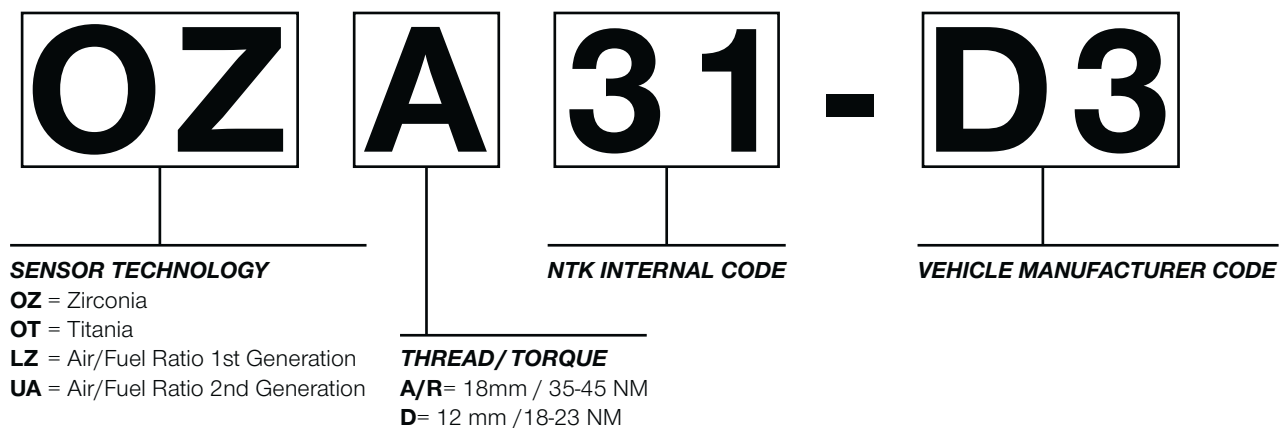

 **DE // So lesen Sie unsere Teilenummern: Sauerstoffsensoren**

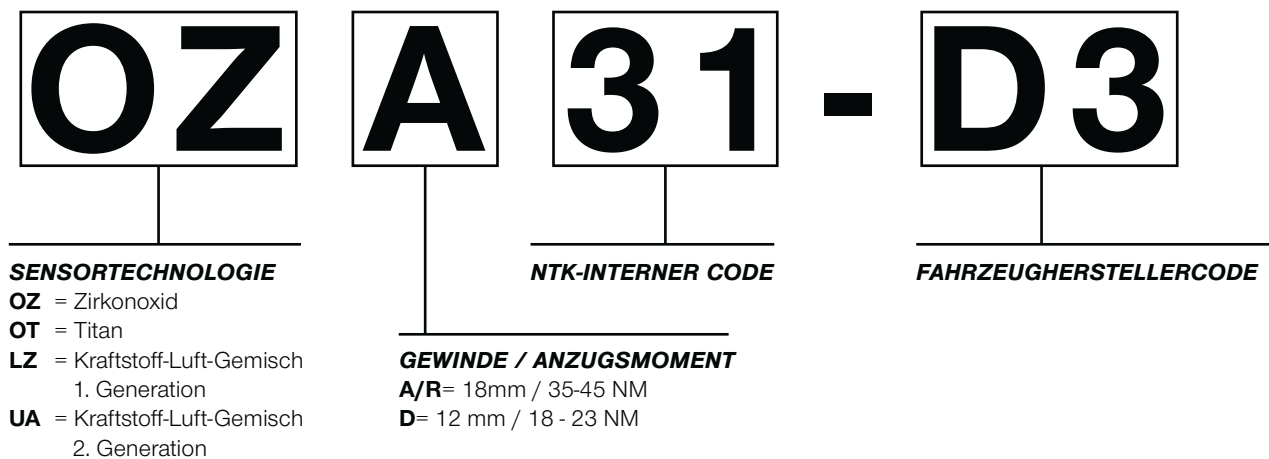

 **FR // Comment lire notre numéro de pièce: Sondes d'oxygène**

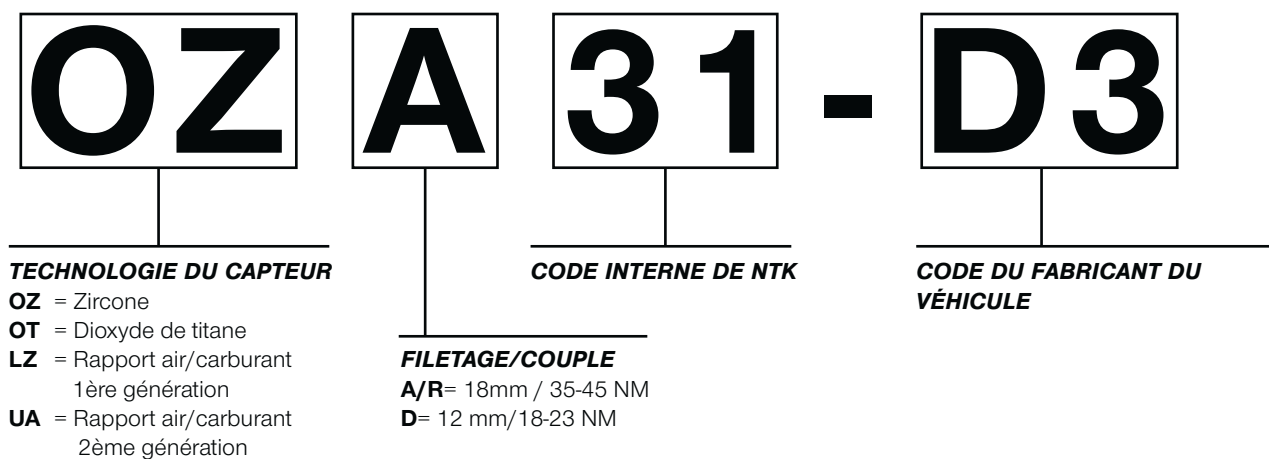

 **IT // Come leggere il nostro numero del pezzo: Sensori di ossigeno**

OZ

TECNOLOGIA DEL SENSORE

OZ = Zirconio

OT = Titano

LZ = Rapporto aria/carburante di
1ª generazione

UA = Rapporto aria/carburante di
2ª generazione

A

FILETTATURA/COPPIA

A/R = 18mm / 35-45 NM

D = 12 mm / 18-23 Nm

31

CODICE INTERNO NTK

-

D3

**CODICE DEL FABBRICANTE
DEL VEICOLO**

 **ES // Cómo leer nuestros números de pieza: Sensores de oxígeno**

OZ

TECNOLOGÍA DEL SENSOR

OZ = Circonio

OT = Titania

LZ = Relación aire/combustible
1ª generación

UA = Relación aire/combustible
2ª generación

A

ROSCA/PAR

A/R = 18mm / 35-45 NM

D = 12 mm / 18-23 NM

31

CÓDIGO INTERNO NTK

-

D3

**CÓDIGO DEL FABRICANTE
DEL VEÍCULO**

 **NL // Hoe moet ons onderdeelnummer worden gelezen: Zuurstofsensoren**

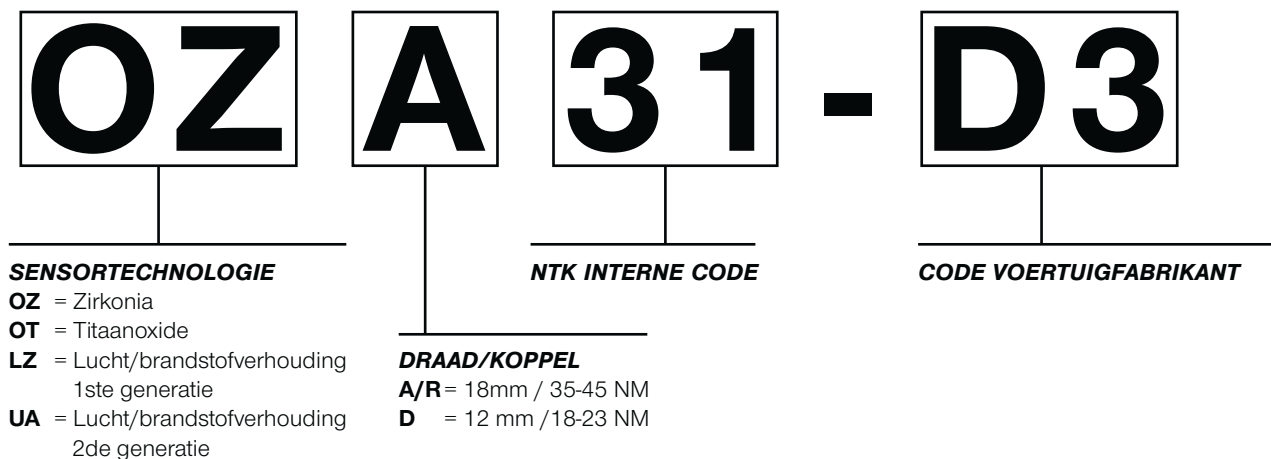

 **PT // Como ler o nosso número de peça: Sensores de Oxigênio**

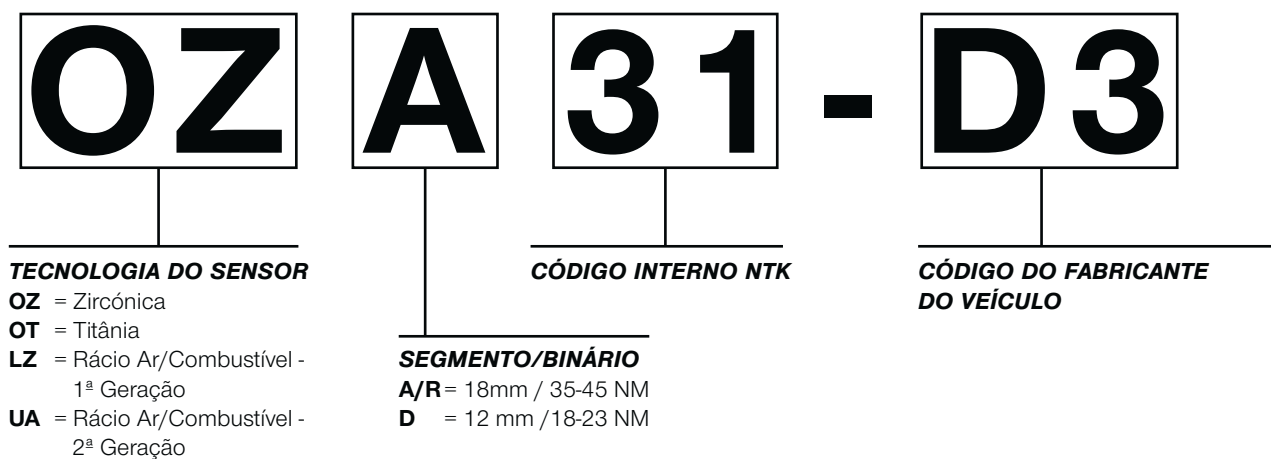

 **GR // Πώς να ερμηνεύετε τους κωδικούς μας: Αισθητήρες οξυγόνου**

OZ

ΤΕΧΝΟΛΟΓΙΑ ΑΙΣΘΗΤΗΡΩΝ

OZ = Ζιρκονίου

OT = Τιτανίου

LZ = Αναλογία αέρα/καυσίμου

1η Γενιά

UA = Αναλογία αέρα/καυσίμου

2η Γενιά

A

ΣΠΕΙΡΩΜΑ/ΡΟΠΗ

A/R = 18mm / 35-45 NM

D = 12 mm / 18-23 NM

31

ΚΩΔΙΚΟΣ NTK

-

D3

ΚΩΔΙΚΟΣ ΚΑΤΑΣΚΕΥΑΣΤΗ

 **TR // Parça numaramızın okunma şekli: Oksijen Sensörleri**

OZ

SENSÖR TEKNOLOJİSİ

OZ = Zirkonya

OT = Titanya

LZ = Hava/Yakit Oranı 1. Nesil

UA = Hava/Yakit Oranı 2. Nesil

A

DIŞ/TORK

A/R = 18mm / 35-45 NM

D = 12 mm / 18-23 NM

31

NTK DAHİLİ KODU

-

D3

ARAÇ ÜRETİCİSİ KODU

PL // Jak odczytać numer części: Czujniki tlenu

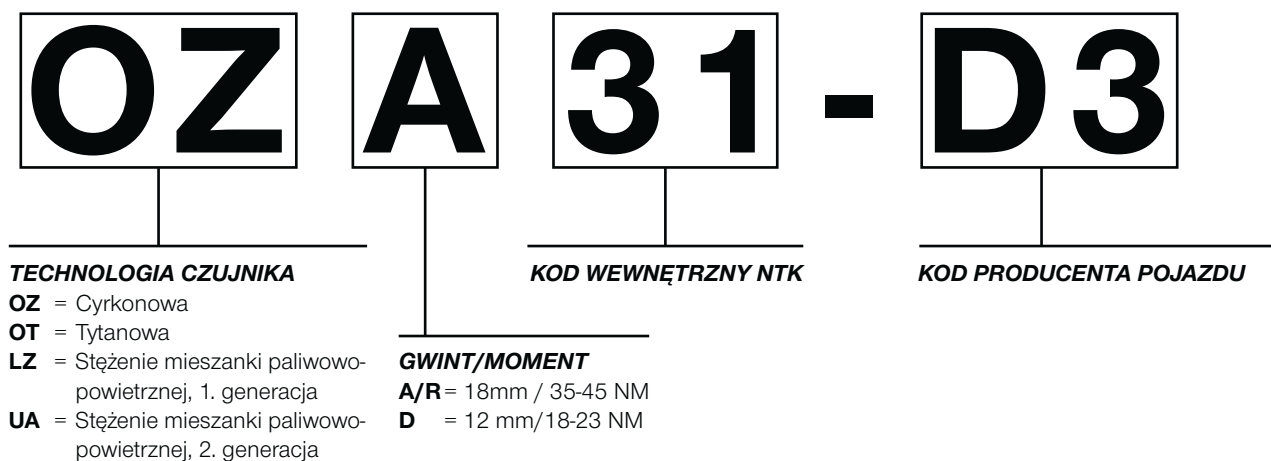

CZ // Jak číst naše číslo dílu: Kyslíkové senzory

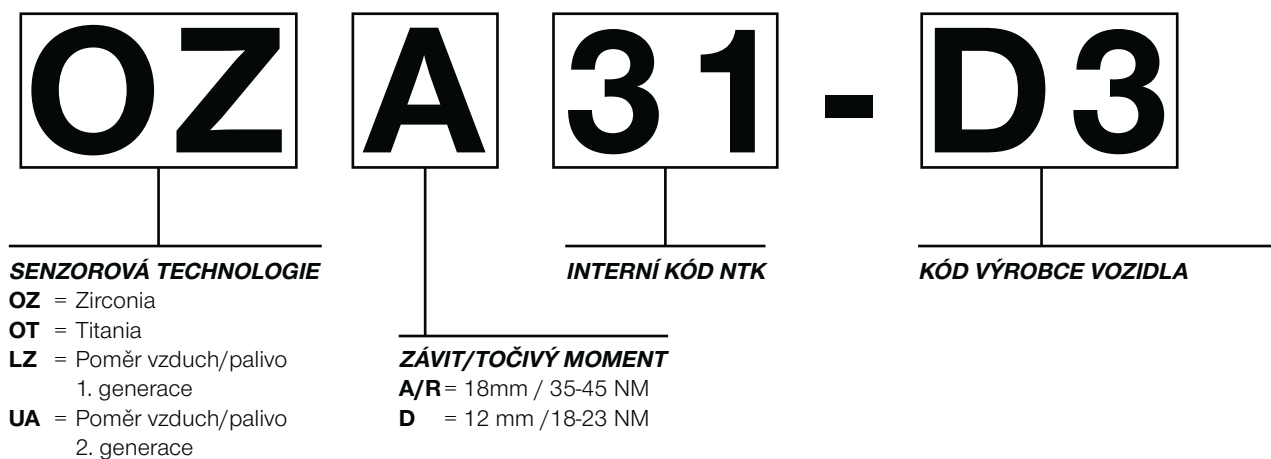

 **HU //** Hogyan kell leolvasni a cikkszámot: Oxigén-érzékelők

OZ

ÉRZÉKELŐ TECHNOLÓGIA

OZ = Cirkónium

OT = Titán

LZ = Levegő/üzemanyag arány
1. generáció

UA = Levegő/üzemanyag arány
2. generáció

A

MENET/NYOMATÉK

A/R = 18mm / 35-45 NM

D = 12 mm /18-23 NM

31

NTK BELSŐ KÓD

-

D3

JÁRMŰGYÁRTÓ KÓD

 **RU //** Что означает код детали: Кислородные датчики

OZ

**ТЕХНОЛОГИЯ В ОСНОВЕ
ДАТЧИКА**

OZ = Циркониевый

OT = Титановый

LZ = Соотношение компонентов
в горючей смеси 1-е поколение

UA = Соотношение компонентов
в горючей смеси 2-е поколение

A

РЕЗЬБА/МОМЕНТ ЗАТЯЖКИ

A/R = 18mm / 35-45 Нм

D = 12 мм /18-23 Нм

31

ВНУТРЕННИЙ КОД NTK

-

D3

КОД АВТОПРОИЗВОДИТЕЛЯ

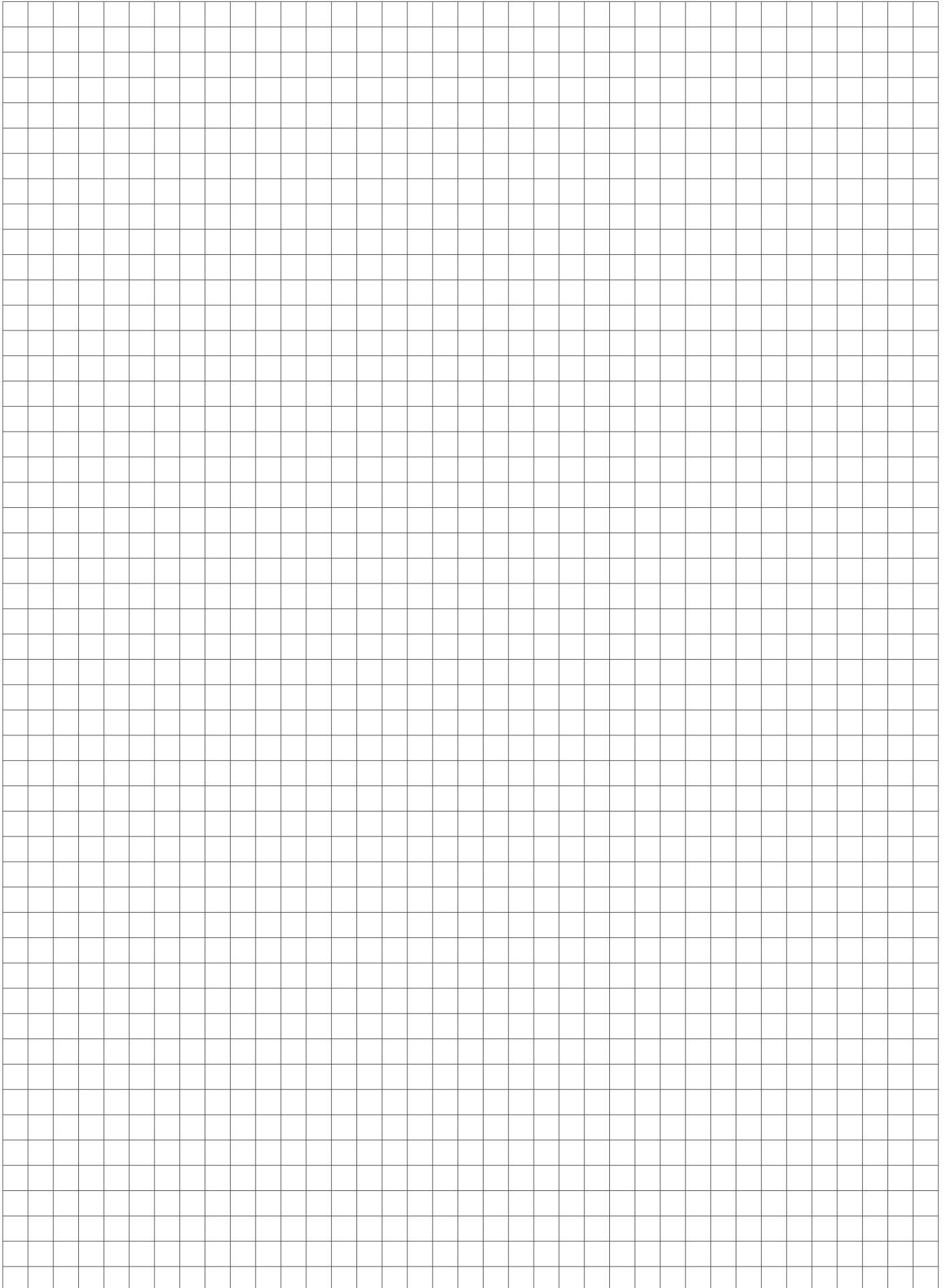

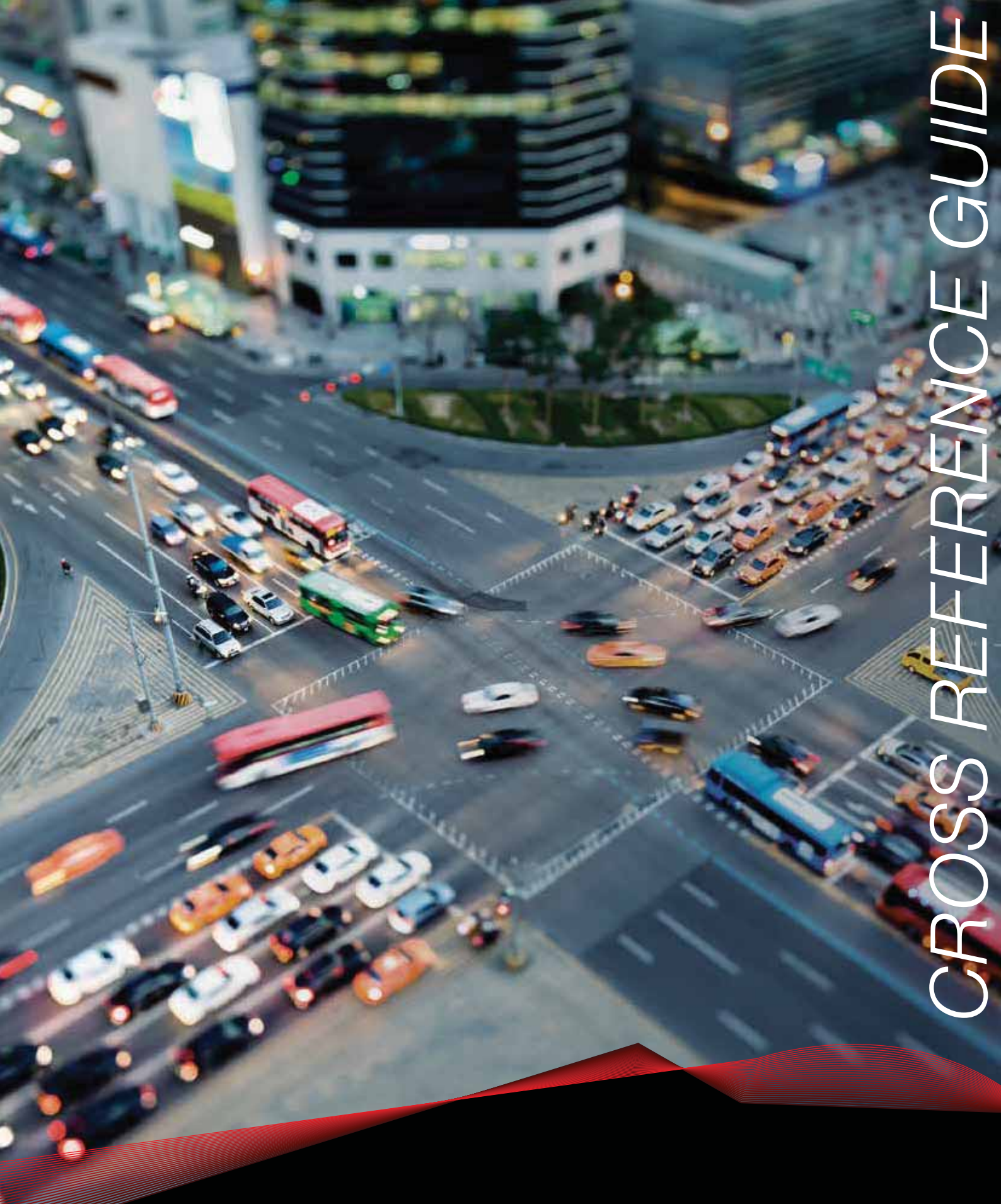

CROSS REFERENCE GUIDE



IGNITION
PARTS



ACDelco	→ NGK	Quick
41-101	ITR4A15	
41-109	ILTR6E11	
412 XLS	BP7ES	Q206
414 XLS	BP6ES	
41-600	TR55IX	
41-601	BPR6ES	
41-602	FR5	
41-603	FR4	
41-606	TR55	
41-608	FR45	
41-610	FR4	
41-611	FR45	
41-627	BKR4E-11	
41-628	FR4	
41-812	TR6IX	
41-900	TR5	
41-902	TR55	
41-904	TR5	
41-905	UR4	
41-906	TR5	
41-907	TR5	
41-908	BPR5EFIX-13P	
41-910	TR5	
41-913	TR55	
41-919	TR55	
41-921	TR55	
41-928	TR55-1	
41-929	TR55	
41-932	TR55	
41-933	ITR4A15	
41-936	TR55	
41-940	TR55	
41-942	TR55	
41-943	TR55	
41-947	TR55	
41-948	TR4IX	
41-950	PTR5C-13	
41-952	BPR5EFIX-13P	
41-963	PTR5C-13	
41-974	PZTR5A-15	
41-983	PZTR5A-15	
41-987	PTR5C-13	
40 TS	BP7FS	
41 F	B6HS-10	
41 TS	BP6FS	
41 XL	B9ES	Q202
41 XLS	BP7ES	Q206
42 F	B6HS	Q203
42 FF	B6HS	Q203
42 FS	BP6HS	
42 S	BP6S	
42 TS	BP6FS	

ACDelco	→ NGK	Quick
42 XL	B8ES	Q201
42 XLS	BP6ES	
43 F	B6HS	Q203
43 FFS	BP6HS	
43 FS	BP6HS	
43 N	B7ES	
43 S	BP6S	
43 TS	BP6FS	
43 XL	B7ES	
43 XLS	BP6ES	
44	B6S	Q302
44 F	B5HS	
44 FF	B5HS	
44 FFS	BP5HS	
44 N	B6ES	
44 NS	BP5ES	
44 S	BP5S	
44 TS	BP5FS	
44 XL	B6ES	
44 XLO	BP5ES	
44 XLS	BP5ES	
45	B-4	
45 F	B5HS	
45 FF	B5HS	
45 FFS	BP5HS	
45 L	B-4L	
45 NS	BP5ES	
45 S	BP5S	
45 TS	BP4FS	
45 XL	B6ES	
45 XLS	BP5ES	
46	B-4	
46 F	B5HS	
46 FF	B5HS	
46 FFS	BP5HS	
46 N	B5ES	
46 S	BP5S	
46 TS	BP4FS	
46 XL	B5ES	
46 XLS	BP4ES	
47 FF	B-4H	
47 S	BP-4	
47 XL	B4ES	
48	B-4	
83 CTS	AP6FS	
83 TS	AP6FS	
84 T	A6FS	
84 TS	AP5FS	
85 TS	AP5FS	
86 TS	AP5FS	
420 Z	B-4H	
422 Z	B5HS	



ACDelco	→ NGK	Quick
425 F	B6HS	Q203
425 Z	B6HS	Q203
426 FS	BP6HS	
430 Z	B7HS	Q204
436 XLS	BP9ES	
438 XLS	BP8ES	
440 T	B7FS	
440 XLS	BP8ES	
445 Z	B8HS	Q205
B 43	B6S	Q302
B 44 FS	BP5HS	
B 44 S	BP5S	
B 45	B-4	
B 4021	B6S	Q302
B 4031	B-4	
C 41	B7S	
C 42 CFS	BP6HS	
C 42 CLTS	BP6EFS	
C 42 CXLS	BP6ES	
C 42 LTS	BP6EFS	
C 42 N	B7ES	
C 42 XLS	BP5ES	
C 43	B6S	Q302
C 43 CXLS	BP6ES	
C 43 L	B-6L	
C 43 N	B6ES	
C 44	B6S	Q302
C 44 N	B6ES	
C 44 NS	BP5ES	
C 44 S	BP5S	
C 44 XL	B6ES	
C 45	B-4	
C 45 L	B-4L	
C 46	B-4	
C 47	B-4	
C 47 W	B-4	
C 49	B-2	
C 73	G-2Z	
C 75	G-2Z	
C 81	AB-8	
C 82	AB-7	
C 82 T	A7FS	
C 83	AB-7	
C 83 T	A6FS	
C 84 T	A6FS	
C 85	AB-6	
C 85 TS	AP5FS	
C 86	AB-6	
C 87	AB-6	
C 88	AB-2	
C 88 L	AB-2	
C 421	B6S	Q302

ACDelco	→ NGK	Quick
CFR 1 CLS	BCPR7ES	
CFR 2 CLS	BKR6ES	
CR 42 CFS	BPR6FS	
CR 42 CXLS	BPR6ES	
CR 42 N	BR7ES	
CR 43	BR6S	
CR 43 CXLS	BPR6ES	
CR 43 K	BR6S	
CR 43 N	BR6ES	
CR 43 S	BP6S	
CR 43 TS	BPR5FS-11	
CR 43 TSM	BPR5FS-11	
CR 44 N	BR6ES	
CR 44 NS	BPR5ES	
CR 44 TS	BPR5FS-11	
CR 45 TS	UR4	
CR 83 T	AR6FS	
CS 40	BM7A	
CS 41	BM7A	
CS 41 T	BM7F	
CS 42	BM7A	
CS 42 S	BM7A	
CS 42 T	BM6F	
CS 45	BM6A	Q303
CS 45 T	BM6F	
CS 49	BM4A	
CSR 45	BMR6A	Q307
FR 2 LS	BKR6ES	
FR 2 LSK	BKR6ES	
FR 3 CLS	BKR5ES	
FR 3 CLS 6	BKR5ES-11	
FR 3 LM	ZFR5A-11	
FR 3 LS	BKR5ES	
FR 3 LS 6	BKR5ES-11	
FR 3 LSJ	BKR4E-11	
FR 3 LSK	BKR5ES	
FR 4 LE	ZFR4F-11	
FR 4 LSJ	BKR4E-11	
FR 5 LS	BKR5ES	
LM 46	B4-LM	Q301
LM 49	B4-LM	Q301
M 40 FF	B9HS	
M 40 FFX	B9HS-10	
M 41 FF	B8HS	Q205
M 41 K	B8S	
M 42 FF	B7HS	Q204
M 42 K	B7S	
M 43 FF	B6HS	Q203
M 43 S	BP6S	
M 44 B	B6S	Q302
M 44 C	B6S	Q302
M 44 L	B-6L	



ACDelco	→ NGK	Quick
M 45	B-4	
M 45 FF	B5HS	
M 47	B-4	
M 86	AB-6	
MB 42 K	B6S	Q302
MC 41	B8S	
MC 41 F	B8HS	Q205
MC 42	B8S	
MC 42 F	B7HS	Q204
MC 44	B7S	
MC 104 F	C6HSA	
MC 122 F	D8HA	
MC 124 FS	D6HA	
MR 42 K	BR6S	
MR 42 LTS	BPR6EFS	
MR 43 LTS	BPR6EFS	
MR 43 T	BR6FS	
MR 44 C	BR6S	
MR 44 T	BR5FS	
MR 45	B-4	
R 41 CF	BR7HS	Q211
R 41 CXL	BR9ES	Q208
R 41 CXLS	BPR7ES	
R 41 TS	BPR6FS	
R 42 CF	BR6HS	Q209
R 42 CFS	BPR6HS	
R 42 CFS	BPR6HS	Q214
R 42 CFS	BPR6HS	
R 42 CLTS	BPR6EFS	
R 42 CT	BR6FS	
R 42 CTS	BPR6FS	
R 42 CXL	BR8ES	Q207
R 42 CXLS	BPR6ES	
R 42 FS	BPR6HS	
R 42 FS	BPR6HS	Q214
R 42 FS	BPR6HS	
R 42 LTS	BPR6EFS	
R 42 LTSM	BPR5EFS-13	
R 42 S	BP6S	
R 42 T	BR6FS	
R 42 TS	BPR6FS	
R 42 TSM	BPR6FS	
R 42 TX	BR6FS	
R 42 XL	BR8ES	Q207
R 42 XLS	BPR6ES	
R 42 XLSM	ZGR5C	
R 43	BR6S	
R 43 C	BR6S	
R 43 CFS	BPR6HS	
R 43 CFS	BPR6HS	Q214
R 43 CFS	BPR6HS	
R 43 CNTSE	TR5-1	

ACDelco	→ NGK	Quick
R 43 CS	BP6S	
R 43 CT	BR6FS	
R 43 CTS	BPR6FS	
R 43 CTS 6	BPR6FS	
R 43 CXL	BR7ES	
R 43 CXLS	BPR6ES	
R 43 FS	BPR6HS	
R 43 FS	BPR6HS	Q214
R 43 FS	BPR6HS	
R 43 LTS	BPR6EFS	
R 43 LTSE	TR4	
R 43 LTSX	BPR6EFS-13	
R 43 N	BR7ES	
R 43 NTSE	TR5-1	
R 43 S	BP6S	
R 43 T	BR6FS	
R 43 TS	BPR6FS	
R 43 TSK	BPR6FS	
R 43 TSX	BPR6FS	
R 43 TX	BR6FS	
R 43 XL	BR7ES	
R 43 XLS	BPR6ES	
R 44	BR6S	
R 44 CF	BR5HS	
R 44 CNTSE	TR5-1	
R 44 CXL	BR6ES	
R 44 CXLS	BPR5ES	
R 44 F	BR5HS	
R 44 LTS	BPR5EFS	
R 44 LTS 6	BPR5EFS-13	
R 44 LTS 6K	BPR5EFS-13	
R 44 LTSM	TR4	
R 44 LTSM 6	TR4	
R 44 N	BR6ES	
R 44 NS	BPR5ES	
R 44 NTSE	TR5-1	
R 44 S	BP5S	
R 44 T	BR5FS	
R 44 TS	BPR5FS	
R 44 TSX	BPR5FS-15	
R 44 TX	BR5FS	
R 44 XL	BR6ES	
R 44 XLS	BPR5ES	
R 44 XLS 6	BPR4ES-13	
R 44 XLSE	ZGR5C	
R 44 XLSM	ZGR5C	
R 45	BR6S	
R 45 LTS 6	BPR5EFS-13	
R 45 LTS 6K	BPR5EFS-13	
R 45 NS	BPR5ES	
R 45 NSX	BPR5ES-13	
R 45 NTSE	TR5-1	



AUTOLITE / TUNER	→ NGK	Quick
45	APR5FS	
46	APR5FS	
52	BP7ES	Q206
53	BP6ES	
54	BP6ES	
55	BP5ES	
56	BP5ES	
57	BP4ES	
62	BP7ES	Q206
63	BPR6ES	
64	BPR6ES	
65	BPR5ES	
66	BPR5ES	
67	BPR4ES	
73	BP6S	
74	BP6S	
75	BP5S	
76	BP5S	
77	BP-4	
84	BP6S	
85	BP5S	
86	BP-4	
87	BP-4	
94	BP7EFS	
102	BP7EFS	
103	BPR6EFS	
104	BPR6EFS	
105	BPR5EFS	
106	BPR5EFS	
113	A7FS	
115	A6FS	
117	A6FS	
124	AR6FS	
135	B7FS	
136	BR6FS	
143	BR6FS	
144	BR6FS	
145	BR6FS	
146	BR5FS	
147	BR5FS	
156	AP5FS	
166	APR5FS	
175	BP5S	
203	BPR6FS	
215	B-6L	
216	B-6L	
217	B-4L	
218	B-4L	
235	BM6A	Q303
245	BMR6A	Q307
253	BM7A	
254	BM6A	Q303

AUTOLITE / TUNER	→ NGK	Quick
255	BM6A	Q303
258	BM4A	
273	BP6HS	
274	BP6HS	
275	BP5HS	
276	BP5HS	
283	BPR7HS	Q215
284	BPR6HS	
284	BPR6HS	Q214
284	BPR6HS	
292	B8S	
294	B6S	Q302
295	B-4	
297	B-4	
298	B-2	
302	BR6S	
303	BR6S	
304	BR6S	
306	B-4	
308	B-2	
312	B8S	
313	B7S	
314	B6S	Q302
315	B6S	Q302
316	B6S	Q302
317	B-4	
318	B-2	
344	AR6FS	
353	B8S	
354	B6S	Q302
355	B6S	Q302
356	B-4	
357	B-4	
358	B-2	
363	BR6S	
372	AB-8	
373	AB-7	
374	AB-7	
375	AB-6	
376	AB-6	
377	AB-6	
378	AB-6	
379	AB-2	
386	AB-6	
393	B7ES	
394	B6ES	
395	B5ES	
396	B5ES	
397	B5ES	
398	B4ES	
402	BR8ES	Q207
403	BR6ES	



AUTOLITE / TUNER	→ NGK	Quick
404	BR6ES	
405	BR5ES	
406	BR5ES	
411	B9HS	
413	B7HS	Q204
414	B6HS	Q203
415	B5HS	
416	B5HS	
417	B-4H	
424	B6HS	Q203
425	BR5HS	
426	BR5HS	
436	B-6L	
437	B-4L	
456	B4-LM	Q301
458	B2-LM	
472	B9EFS	
483	BR7EFS	
494	B-6L	
495	B-6L	
497	B-4L	
515	BP5HS	
516	BP5HS	
517	BP-4H	
535	B5HS	
536	B-4H	
584	AR6FS	
603	BPR6EFS-13	
604	BPR6EFS-13	
605	BPR6EFS-13	
646	BPR5ES-13	
664	BPR6FS	
665	BPR5FS-15	
666	BPR4FS-15	
667	BPR4FS-15	
683	BR6FS	
684	BR6FS	
685	BR6FS	
687	BR5FS	
723	BPR6FS	
724	BPR6FS	
725	BPR5FS-11	
726	BPR4FS	
727	BPR4FS-11	
744	APR5FS	
746	APR5FS	
747	APR5FS	
763	TR5-1	
764	BPR6EFS	
765	BPR5EFS	
766	BPR5EFS	
784	AR6FS	

AUTOLITE / TUNER	→ NGK	Quick
804	AR6FS	
865	BPR5EFS	
884	BPR6EFS-13	
915	ZGR5C	
925	ZGR5C	
935	BPR5ES	
945	BPR5ES	
985	ZFR4F-11	
996	B-6L	
2272	AB-7	
2413	R7376-10	
2414	B10EG	
2415	B9EG	
2416	B8EG	
2417	B7ECS	
2543	TR5-1	
2544	TR5-1	
2545	TR5-1	
2546	TR5-1	
2585	BPR5ES	
2592	B10ES	
2593	B9ES	Q202
2594	B9ES	Q202
2611	B10ES	
2612	B9ES	Q202
2613	B9ES	Q202
2614	B8ES	Q201
2615	B7ES	
2616	B6ES	
2634	B9HS-10	
2635	B8HS	Q205
2636	B7HS	Q204
2652	B9HS-10	
2653	B7HS	Q204
2654	B7HS	Q204
2655	B6HS	Q203
2656	B5HS	
2675	B-6L	
2676	B-6L	
2695	AB-8	
2696	AB-7	
2697	AB-6	
2715	D8HA	
2716	D6HA	
2735	D6HA	
2755	D8EA	Q216
2772	AB-8	
2775	AB-6	
2794	C8HSA	
2795	C7HSA	
2796	C6HSA	
2852	BUH	



AUTOLITE / TUNER	→ NGK	Quick
2872	BUHW	
2892	BUHX	
2932	BUE	
2954	BM7F	
2956	BM6F	
2974	BPM7A	Q305
3012	B8S	
3013	B7S	
3014	B6S	Q302
3017	B-4	
3035	AB-6	
3036	BPR4FS-15	
3055	A6FS	
3074	G-2Z	
3075	G-2Z	
3116	AB-6	
3203	BPR6ES	
3204	BPR6ES	
3205	BPR5ES	
3206	BPR5ES	
3207	BPR5ES	
3224	BP6S	
3225	BP5S	
3226	BP5S	
3227	BP5S	
3243	BPR6EFS	
3244	BPR6EFS	
3245	BPR5EFS	
3246	BPR5EFS	
3264	B7FS	
3265	BR6FS	
3266	BR5FS	
3267	BR5FS	
3286	APR6FS	
3303	BPR6FS	
3325	B-6L	
3327	B-4L	
3345	BMR7A	
3364	BPR6HS	
3364	BPR6HS	Q214
3364	BPR6HS	
3382	BR6S	
3383	BR6S	
3384	BR6S	
3386	BR6S	
3388	BR6S	
3404	AR6FS	
3423	B8S	
3426	BR6S	
3462	BR7ES	
3463	BR6ES	
3464	BR6ES	

AUTOLITE / TUNER	→ NGK	Quick
3465	BR5ES	
3466	BR5ES	
3485	BR5HS	
3486	BR5HS	
3507	B-6L	
3565	BPR5EFS	
3586	BPR5ES-13	
3604	BPR5FS-15	
3605	BPR4FS-15	
3606	BPR4FS-15	
3607	BPR4FS-15	
3624	BR6FS	
3625	BR6FS	
3627	BR5FS	
3666	B4-LM	Q301
3684	BR7HS	Q211
3686	BR6HS	Q209
3702	BR9ES	Q208
3703	BR9ES	Q208
3704	BR8ES	Q207
3705	BR6ES	
3706	BR6ES	
3724	BPR5EFS	
3885	ZGR5C	
3896	ZGR5C	
3922	BCPR7ES	
3924	BKR6ES	
3926	BKR5ES	
3954	D8EA	Q216
3964	DR8ES-L	Q218
3985	BPR5FS-15	
4043	BPR6ES-11	
4052	B9ES	Q202
4053	B9ES	Q202
4054	B8ES	Q201
4055	B7ES	
4056	B6ES	
4062	BR9ES	Q208
4063	BR9ES	Q208
4092	B7HS	Q204
4093	B7HS	Q204
4113	BP6HS	
4114	BP6HS	
4123	BPR6HS	
4123	BPR6HS	Q214
4123	BPR6HS	
4132	D8EA	Q216
4143	DR8ES-L	Q218
4152	DP9EA-9	
4153	DP8EA-9	
4162	DPR7EA-9	Q220
4163	DR8ES-L	Q218



AUTOLITE / TUNER	→ NGK	Quick
4164	D7EA	
4173	D8HA	
4193	C7HSA	
4203	CR7HS	
4251	BP8ES	
4252	BP7ES	Q206
4253	BP6ES	
4263	BPR6ES	
4265	BPR5ES	
4275	BP5S	
5143	TR5-1	
5224	BKR5E	
9062	BUR6ET	
9063	BUR6ET	
9064	BP5ET	
9921	BCPR6ET	
AP 63	PFR6B	
APP 392 411	BKR5EP-11	

BERU	→ NGK	Quick
0 001 245 700	D7EA	
0 001 325 701	BP5ES	
0 001 325 704	BP5ESZ	
0 001 325 705	BCP5ES	
0 001 325 710	BP5ET	
0 001 330 104	BUR5ET	
0 001 330 112	BUR5ET-10	
0 001 330 113	BUR5ET	
0 001 330 116	BKUR5ET-10	
0 001 330 119	BKUR5ET	
0 001 330 501	BKR6EK	
0 001 330 702	BP5ES	
0 001 330 707	BCP5ES	
0 001 330 709	BP5ET-10	
0 001 330 713	BP5ESZ	
0 001 330 717	ZFR5F	
0 001 330 718	ZGR5A	
0 001 330 725	BCP5ES	
0 001 330 726	BP5ESZ	
0 001 330 731	BCP5ES	
0 001 330 780	BKR6EZB	
0 001 330 904	IFR5D10	
0 001 335 107	BKUR6ET-10	
0 001 335 107	BKUR6ET-10	
0 001 335 108	BUR6ET	
0 001 335 702	BP6ES	
0 001 335 707	B6ES	
0 001 335 709	BUR6ET	
0 001 335 714	BP6ESZ	
0 001 335 721	BCP6ES	
0 001 335 725	BCP6ES	
0 001 335 729	BKR6ES	

BERU	→ NGK	Quick
0 001 335 732	BKR6EK	
0 001 335 737	BP6ESZ	
0 001 335 742	ZFR5P-G	
0 001 335 905	IFR6D10	
0 001 335 910	IFR6D10	
0 001 335 911	PZFR5D-11	
0 001 335 914	PFR6Q	
0 001 340 103	BKUR6ET	
0 001 340 702	BP6ES	
0 001 340 704	BUR6ET	
0 001 340 706	BCP6ET	
0 001 340 707	BP6ESZ	
0 001 340 716	BCP6ES	
0 001 340 717	BCP6ET	
0 001 340 723	BKR6ES	
0 001 340 806	BKR6ES	
0 001 340 903	BP6ES	
0 001 340 908	PFR7Q	
0 001 345 702	BP7ES	Q206
0 001 345 704	BUR6ET	
0 001 345 711	BP7ES	Q206
0 001 345 720	BCP7ES	
0 001 350 903	BP7ES	Q206
0 001 355 700	B9ES	Q202
0 001 400 701	B6HS	Q203
0 001 430 700	BP5HS	
0 001 430 701	B5HS	
0 001 435 700	BP6HS	
0 001 435 705	B6HS	Q203
0 001 440 700	BP6HS	
0 001 445 700	BP7HS	
0 001 445 702	B7HS	Q204
0 001 450 702	B8HS	Q205
0 001 455 702	B9HS	
0 001 529 302	B-4	
0 001 625 700	BP5EFS	
0 001 625 702	BP5EFS	
0 001 630 700	BP5EFS	
0 001 630 704	BP5EFS	
0 001 635 700	BP6EFS	
0 001 635 709	BP6EFS	
0 001 640 700	BP6EFS	
0 001 640 704	BP6EFS	
0 001 640 705	BP6EFS	
0 001 645 700	BP7EFS	
0 001 645 703	BP7EFS	
0 001 735 700	AP6FS	
0 001 740 700	AP6FS	
0 001 820 700	AB-6	
0 001 835 700	AB-7	
0 001 845 700	AB-7	
0 002 235 901	PLZKBR7B8DG	



BERU	→ NGK	Quick
0 002 240 902	PLZKBR7B8DG	
0 002 240 907	PLZKBR7B8DG	
0 002 240 911	PLZKBR7B8DG	
0 002 325 700	BPR5ES	
0 002 330 204	BKR5EYA-11	
0 002 330 701	BPR5ES	
0 002 330 702	BPR5ES-11	
0 002 330 703	BKR5ES	
0 002 330 704	BKR5ES-11	
0 002 330 706	BPR5EKU	
0 002 330 710	BKR5EK	
0 002 330 712	BCRE527Y	
0 002 330 713	BKR5EY	
0 002 330 714	BKR5EYA	
0 002 330 794	ZFR5F	
0 002 335 100	BCPR7ET	
0 002 335 500	BKR6EK	
0 002 335 701	BPR6ES	
0 002 335 704	BR6ES	
0 002 335 706	BPR6ES-11	
0 002 335 707	BKR6ES	
0 002 335 708	BKR6ES-11	
0 002 335 712	BKR6EY	
0 002 335 713	BKR6EYA	
0 002 335 714	BKR6EYA-11	
0 002 335 715	ZFR6F-11	
0 002 335 719	LFR6B	
0 002 335 719	LFR6B	
0 002 335 902	BCPR6EP-11	
0 002 335 903	BCPR6EP-11	
0 002 335 904	BKR6EP-8	
0 002 335 911	BKR6EQUP	
0 002 340 102	BKR6EKUB	
0 002 340 500	BKR6EK	
0 002 340 501	BKR6EKE	
0 002 340 504	BKR6EKC	
0 002 340 701	BPR6ES	
0 002 340 702	BKR6ES	
0 002 340 703	BPR6ES-11	
0 002 340 704	BKR6ES-11	
0 002 345 701	BPR7ES	
0 002 345 702	BCPR7ES	
0 002 345 704	BCPR7ET	
0 002 435 701	BPR6HS	
0 002 435 701	BPR6HS	Q214
0 002 435 701	BPR6HS	
0 002 515 400	BP-4	
0 002 630 701	PTR5A-13	
0 002 630 715	LTR6B-10T	
0 002 630 900	TR55IX	
0 002 635 700	BPR6EFS	
0 002 635 701	BPR6EFS-13	

BERU	→ NGK	Quick
0 002 640 100	BUR6EFSZ	
0 002 640 700	BPR6EFS	
0 002 640 701	BPR6FS	
0 002 640 900	PTR5A-13	
0 004 525 700	B4-LM	Q301
0 004 525 701	BR4-LM	
0 004 535 402	BPM6A	Q304
0 004 540 401	BPMR6A	Q308
0 004 545 401	BPM7A	Q305
12-5 DU	D7EA	
14-9 DU	BP5ES	
14-9 DU0	BP5ESZ	
14 F-9 DU0	BCP5ES	
14-9 DTU	BP5ET	
14 G-8 DTU	BUR5ET	
14 GH-8 DTURX	BUR5ET-10	
14 GH-8 DTUR	BUR5ET	
14 FGH-8 DTURX0	BKUR5ET-10	
14 FGH-8 DTURW	BKUR5ET	
14 F-8 LDUSR	BKR6EK	
14-8 DU	BP5ES	
14 F-8 DU	BCP5ES	
14-8 DTU	BP5ET-10	
14-8 DU0	BP5ESZ	
14 F-8 LUR	ZFR5F	
14-8 LUR	ZGR5A	
14 F-8 DU0	BCP5ES	
14-8 DU0	BP5ESZ	
14 F-8 DU4	BCP5ES	
14 F-8 DUR	BKR6EZB	
14 FGH-8 DPURX2	IFR5D10	
14 FGH-7 DTURX	BKUR6ET-10	
14 FGH-7 DTURX	BKUR6ET-10	
14 GH-7 DTUR	BUR6ET	
14-7 DU	BP6ES	
14-7 CU	B6ES	
14-7 DTU	BUR6ET	
14-7 DU0	BP6ESZ	
14 F-7 DU0	BCP6ES	
14 F-7 DU	BCP6ES	
14 F-7 DU0R	BKR6ES	
14 F-7 LDUR4	BKR6EK	
14-7 DU0	BP6ESZ	
14 F-7 HUR2	ZFR5P-G	
14 FGH-7 DPURX2	IFR6D10	
14 F-7 DPURX2	IFR6D10	
14 F-7 HPURX2	PZFR5D-11	
14 F-7 DPUR02	PFR6Q	
14 FGH-6 DTUR	BKUR6ET	
14-6 DU	BP6ES	
14-6 DTU	BUR6ET	
14 F-6 DTU	BCP6ET	



BERU	→NGK	Quick
14-6 DU0	BP6ESZ	
14 F-6 DU0	BCP6ES	
14 F-6 DTU	BCP6ET	
14 F-6 DU0R	BKR6ES	
14 F-6 DSR	BKR6ES	
14-6 DP0	BP6ES	
14 F-6 DPUR 021	PFR7Q	
14-5 DU	BP7ES	Q206
14-5 DTU	BUR6ET	
14-5 DU0	BP7ES	Q206
14 F-5 DU	BCP7ES	
14-4 DP0	BP7ES	Q206
14 Z-3 CU	B9ES	Q202
14 X-AU	B6HS	Q203
14-8 BU	BP5HS	
14-8 AU	B5HS	
14-7 BU	BP6HS	
14-7 AU	B6HS	Q203
14-6 BU	BP6HS	
14-5 BU	BP7HS	
14-5 AU	B7HS	Q204
14 Z-4 AU	B8HS	Q205
14 Z-3 AU	B9HS	
14-8 E	B-4	
14 K-9 DU	BP5EFS	
14 K-9 DU0	BP5EFS	
14 K-8 DU	BP5EFS	
14 K-8 DU0	BP5EFS	
14 K-7 DU	BP6EFS	
14 K-7 DU0	BP6EFS	
14 K-6 DU	BP6EFS	
14 K-6 DU0	BP6EFS	
14 K-6 DU0	BP6EFS	
14 K-5 DU	BP7EFS	
14 K-5 DU0	BP7EFS	
18 K-7 BU	AP6FS	
18 K-6 BU	AP6FS	
18-10 AU	AB-6	
18-7 AU	AB-7	
18-5 AU	AB-7	
12 ZR-7 SP03	PLZKBR7B8DG	
12 ZR-6 SP03	PLZKBR7B8DG	
12 ZR-6 SP2	PLZKBR7B8DG	
12 ZR-6 SPP21	PLZKBR7B8DG	
14 R-9 DU	BPR5ES	
14 FR-8 KU0U	BKR5EYA-11	
14 R-8 DU	BPR5ES	
14 R-8 DUX	BPR5ES-11	
14 FR-8 DU	BKR5ES	
14 FR-8 DUX	BKR5ES-11	
14 GR-8 DTU	BPR5EKU	
14 FR-8 LDUOX4	BKR5EK	

BERU	→NGK	Quick
14 FR-8 HU	BCRE527Y	
14 FR-8 KU	BKR5EY	
14 FR-8 KUO	BKR5EYA	
14 FR-8 LU2	ZFR5F	
14 FGR-7 CTU	BCPR7ET	
14 FR-7 LDU	BKR6EK	
14 R-7 DU	BPR6ES	
14 R-7 CU	BR6ES	
14 R-7 DUX	BPR6ES-11	
14 FR-7 DU	BKR6ES	
14 FR-7 DUX	BKR6ES-11	
14 FR-7 KU	BKR6EY	
14 FR-7 KU0	BKR6EYA	
14 FR-7 KU0X	BKR6EYA-11	
14 FR-7 LUX	ZFR6F-11	
14 FR-7 MU2	LFR6B	
14 FR-7 MU2	LFR6B	
14 FR-7 KPUX	BCPR6EP-11	
14 FR-7 KPUV	BCPR6EP-11	
14 FR-7 KPU	BKR6EP-8	
14 FR-7 DQUP7	BKR6EQUP	
14 FGR-6 DDU	BKR6EKUB	
14 FR-6 LDU	BKR6EK	
14 FR-6 LDU3	BKR6EKE	
14 FR-6 LDUW	BKR6EKC	
14 R-6 DU	BPR6ES	
14 FR-6 DU	BKR6ES	
14 R-6 DUX	BPR6ES-11	
14 FR-6 DUX	BKR6ES-11	
14 R-5 DU	BPR7ES	
14 FR-5 DU	BCPR7ES	
14 FR-5 DTU	BCPR7ET	
14 R-7 BU	BPR6HS	
14 R-7 BU	BPR6HS	Q214
14 R-7 BU	BPR6HS	
14 R-11 F	BP-4	
14 KR-8 MUV	PTR5A-13	
14 KR-8 STUX	LTR6B-10T	
14 KR-8 DPU0V	TR55IX	
14 KR-7 DU	BPR6EFS	
14 KR-7 DUX	BPR6EFS-13	
14 KGR-6 KQU	BUR6EFSZ	
14 KR-6 DU	BPR6EFS	
14 KR-6 BU	BPR6FS	
14 KR-8 MPX	PTR5A-13	
14-9 EU0	B4-LM	Q301
14 R-9 EU0	BR4-LM	
14 S-7 F	BPM6A	Q304
14 SR-6 F	BPMR6A	Q308
14 S-5 F	BPM7A	Q305
Z 35	D7EA	
Z 76	BP5ES	



BERU	→ NGK	Quick
Z 77	BP5ESZ	
Z 79	BCP5ES	
Z 78	BP5ET	
Z 75	BUR5ET	
Z 93	BUR5ET-10	
Z 92	BUR5ET	
Z 121	BKUR5ET-10	
Z 246	BKUR5ET	
Z 101	BKR6EK	
Z 1	BP5ES	
Z 71	BCP5ES	
Z 2	BP5ET-10	
Z 69	BP5ESZ	
Z 4	ZFR5F	
Z 3	ZGR5A	
Z 5	BCP5ES	
Z 70	BP5ESZ	
Z 100	BCP5ES	
Z 227	BKR6EZB	
Z 122	IFR5D10	
Z 90	BKUR6ET-10	
Z 90	BKUR6ET-10	
Z 91	BUR6ET	
Z 11	BP6ES	
Z 58	B6ES	
Z 12	BUR6ET	
Z 61	BP6ESZ	
Z 64	BCP6ES	
Z 63	BCP6ES	
Z 13	BKR6ES	
Z 14	BKR6EK	
Z 62	BP6ESZ	
Z 200	ZFR5P-G	
Z 282	IFR6D10	
Z 171	IFR6D10	
Z 176	PZFR5D-11	
Z 188	PFR6Q	
Z 89	BKUR6ET	
Z 22	BP6ES	
Z 51	BUR6ET	
Z 52	BCP6ET	
Z 50	BP6ESZ	
Z 54	BCP6ES	
Z 53	BCP6ET	
Z 23	BKR6ES	
Z 105	BKR6ES	
Z 104	BP6ES	
Z 185	PFR7Q	
Z 42	BP7ES	Q206
Z 44	BUR6ET	
Z 43	BP7ES	Q206
Z 29	BCP7ES	

BERU	→ NGK	Quick
Z 103	BP7ES	Q206
Z 38	B9ES	Q202
Z 85	B6HS	Q203
Z 118	BP5HS	
Z 68	B5HS	
Z 10	BP6HS	
Z 57	B6HS	Q203
Z 48	BP6HS	
Z 41	BP7HS	
Z 40	B7HS	Q204
Z 39	B8HS	Q205
Z 37	B9HS	
Z 112	B-4	
Z 80	BP5EFS	
Z 81	BP5EFS	
Z 6	BP5EFS	
Z 7	BP5EFS	
Z 17	BP6EFS	
Z 18	BP6EFS	
Z 25	BP6EFS	
Z 55	BP6EFS	
Z 56	BP6EFS	
Z 31	BP7EFS	
Z 46	BP7EFS	
Z 32	AP6FS	
Z 33	AP6FS	
Z 88	AB-6	
Z 87	AB-7	
Z 86	AB-7	
Z 288	PLZKBR7B8DG	
Z 233	PLZKBR7B8DG	
Z 336	PLZKBR7B8DG	
Z 82	BPR5ES	
Z 249	BKR5EYA-11	
Z 8	BPR5ES	
Z 9	BPR5ES-11	
Z 72	BKR5ES	
Z 73	BKR5ES-11	
Z 94	BPR5EKU	
Z 74	BKR5EK	
Z 152	BCRE527Y	
Z 153	BKR5EY	
Z 154	BKR5EYA	
Z 203	ZFR5F	
Z 60	BCPR7ET	
Z 98	BKR6EK	
Z 20	BPR6ES	
Z 59	BR6ES	
Z 21	BPR6ES-11	
Z 15	BKR6ES	
Z 16	BKR6ES-11	
Z 155	BKR6EY	

BERU	→NGK	Quick
Z 156	BKR6EYA	
Z 157	BKR6EYA-11	
Z 158	ZFR6F-11	
Z 184	LFR6B	
Z 184	LFR6B	
Z 149	BCPR6EP-11	
Z 150	BCPR6EP-11	
Z 151	BKR6EP-8	
Z 237	BKR6EQUP	
Z 145	BKR6EKUB	
Z 116	BKR6EK	
Z 194	BKR6EKE	
Z 245	BKR6EKC	
Z 27	BPR6ES	
Z 24	BKR6ES	
Z 28	BPR6ES-11	
Z 99	BKR6ES-11	
Z 47	BPR7ES	
Z 30	BCPR7ES	
Z 45	BCPR7ET	
Z 19	BPR6HS	
Z 19	BPR6HS	Q214
Z 19	BPR6HS	
Z 107	BP-4	
Z 177	PTR5A-13	
Z 222	LTR6B-10T	
Z 148	TR55IX	
Z 95	BPR6EFS	
Z 67	BPR6EFS-13	
Z 144	BUR6EFSZ	
Z 26	BPR6EFS	
Z 49	BPR6FS	
Z 97	PTR5A-13	
Z 83	B4-LM	Q301
Z 84	BR4-LM	
Z 132	BPM6A	Q304
Z 106	BPMR6A	Q308
Z 265	BPM7A	Q305
14-2 AS1	B9HCS	
14-3 A1	B8HS	Q205
14-3 AS1	BR8HIX	
14-3 AU	B8HS	Q205
14-3 CS1	BR8EIX	
14-3 DP2	BR8EIX	
14-4 A1	B8HS	Q205
14-4 A2	B7HS	Q204
14-4 AS1	BR8HIX	
14-4 AU	B7HS	Q204
14-4 B2	BP7HS	
14-4 C1	B8ES	Q201
14-4 C2	B7ES	
14-4 CS1	BR8EIX	

BERU	→NGK	Quick
14-5 A	B7HS	Q204
14-5 B	BP7HS	
14-5 C	B7ES	
14-5 CS	B7ECS	
14-5 D	BP7ES	Q206
14-5 D1	BP7ES	Q206
14-5 DP1	BP7ES	Q206
14-5 E	B7S	
14-5 F	BP6S	
14-6 B	BP6HS	
14-6 C	B6ES	
14-6 D	BP6ES	
14-6 D1	BP6ES	
14-7 A	B6HS	Q203
14-7 B	BP6HS	
14-7 C	B6ES	
14-7 D	BP6ES	
14-7 E	B6S	Q302
14-7 F	BP6S	
14-8 A	B5HS	
14-8 B	BP5HS	
14-8 C	B5ES	
14-8 C1	B6ES	
14-8 D	BP5ES	
14-8 F	BP5S	
14-9 C	B5ES	
14-9 D	BP5ES	
14-10 A	B-4H	
14-10 B	BP4HS	
14-10 C	B4ES	
14-10 D	BP4ES	
14-10 E	B-4	
14-10 F	BP-4	
14 F-7 LDUR	BKR6EK	
14 K-6 D	BP6EFS	
14 K-7 D	BP6EFS	
14 R-6 B	BPR6HS	
14 R-6 B	BPR6HS	Q214
14 R-6 B	BPR6HS	
14 R-6 BU	BPR6HS	
14 R-6 BU	BPR6HS	Q214
14 R-6 BU	BPR6HS	
14 R-6 D	BPR6ES	
14 R-7 B	BPR6HS	
14 R-7 B	BPR6HS	Q214
14 R-7 B	BPR6HS	
14 R-7 D	BPR6ES	
14 S-8 F	BPM6A	Q304
14 Z-2 C1	BR9EIX	
14 Z-3 A1	B9HS	
14 Z-3 C1	B9ES	Q202
14 Z-6 A2	B6HS	Q203



BERU	→ NGK	Quick
14 Z-7 AU	B7HS	Q204
18-4 A1	AB-7	
18-4 A2	AB-7	
18-5 A	AB-7	
18-5 AS	AB-7	
18-7 A	AB-6	
18-8 A	AB-6	
18-10 A	AB-6	
18-12 B	AB-2	
18 K-7 B	AP6FS	
18 K-8 B	AP5FS	
18 K-8 BU	AP5FS	
18 K-12 B	AP5FS	
45/18	AP5FS	
95/14	B-4H	
95/14/3	B4ES	
95/14/3A	BP4ES	
95/14/5	B-4	
95/14/5A	BP-4	
95/14A	BP4HS	
95/18	AB-6	
125/14/3	B5ES	
125/14/3A	BP5ES	
145/14	B5HS	
145/14/3	B5ES	
145/14/3A	BP5ES	
145/14/5	B-4	
145/14/5A	BP5S	
145/14/5AMX	BPM6A	Q304
145/18	AB-6	
145/18K	AP5FS	
145/1A	BP5HS	
160/14/3	B6ES	
175/14	B6HS	Q203
175/14/3	B6ES	
175/14/3A	BP6ES	
175/14/5	B6S	Q302
175/14/5A	BP6S	
175/14/5AMX	BPM6A	Q304
175/14A	BP6HS	
175/18	AB-6	
175/18K	AP6FS	
190/14 Z	B6HS	Q203
200/14/3	B6ES	
200/14/3A	BP6ES	
200/14/3K	BP6EFS	
200/14A	BP6HS	
215/14/3A	BP6ES	
225/14	B7HS	Q204
225/14/3	B7ES	
225/14/3A	BP7ES	Q206
225/14/3S	B7ECS	

BERU	→ NGK	Quick
225/14/5	B7S	
225/14/5A	BP6S	
225/14/5AMX	BPM7A	Q305
225/14A	BP7HS	
225/18	AB-7	
225/18S	AB-7	
230/14/3A	BP7ES	Q206
235/14/3P	BP7ES	Q206
240/14	B7HS	Q204
240/14/3	B7ES	
240/14 A	BP7HS	
240/14 S	BR8HIX	
240/18	AB-7	
260/14	B8HS	Q205
260/14/3	B8ES	Q201
260/14 S	BR8HIX	
260/18	AB-8	
265/14/3P	BR8EIX	
280/14	B8HS	Q205
280/14/3S	BR8EIX	
280/14/3Z	B9ES	Q202
280/14Z	B9HS	
310/14/3Z	BR9EIX	
310/14S	B9HCS	
D 175/14	B6HS	Q203
D 175/14/3	B6ES	
D 200/14/3A	BP6ES	
D 215/14/3	B7ES	
D 230/14/3A	BP7ES	Q206
RS 16	BPR6HIX	
RS 18	BPR7HIX	
RS 33	BPR5EIX	
RS 35	BPR6EIX	
RS 37	BPR7EIX	
RS 39	BPR7EIX	
BOSCH		
→ NGK	Quick	
0 241 040 501	CR4HSA	
0 241 045 001	C5HSA	
0 241 045 003	C5HSA	
0 241 045 502	C5HSA	
0 241 050 002	C6HSA	
0 241 056 501	C7E	
0 241 140 500	DCP6E	
0 241 145 003	DP7EA-9	
0 241 145 500	DP7EA-9	
0 241 145 504	DP7EA-9	
0 241 145 507	D8EA	Q216
0 241 145 515	PZKER7A8EGS	
0 241 150 502	D8EA	Q216
0 241 200 500	BUH	



BOSCH	→ NGK	Quick
0 241 209 003	B-4H	
0 241 219 536	BP-4	
0 241 219 537	BP4FS	
0 241 219 540	B-4H	
0 241 219 541	B4ES	
0 241 219 542	BP4ES	
0 241 219 543	B-4H	
0 241 219 554	B-4	
0 241 219 555	BP4ES	
0 241 225 013	BP5ES	
0 241 225 543	BP4FS	
0 241 225 545	BP5ES	
0 241 225 547	B4ES	
0 241 225 548	B-4	
0 241 225 549	B5HS	
0 241 225 550	BP5ES	
0 241 225 551	B4-LM	Q301
0 241 225 555	BPR4FS-15	
0 241 225 556	BP5ES	
0 241 225 558	BP5EFS	
0 241 225 573	BP5EFS	
0 241 225 574	BCPR4ES-11	
0 241 225 576	BP5ET	
0 241 225 582	BP5ES-11	
0 241 225 585	ZGR5A	
0 241 225 589	BM4A	
0 241 225 590	B4-LM	Q301
0 241 225 593	BP5ES	
0 241 229 059	ZGR5A	
0 241 229 060	BP5ET-10	
0 241 229 061	BP5ES	
0 241 229 062	BP5ES	
0 241 229 541	BM6F	
0 241 229 560	BM6A	Q303
0 241 229 561	BPM6A	Q304
0 241 229 574	BP5ES	
0 241 229 578	BP5HS	
0 241 229 579	B5ES	
0 241 229 580	B6S	Q302
0 241 229 588	BP5ES	
0 241 229 593	BP5S	
0 241 229 594	BP5FS	
0 241 229 596	BP5ES-11	
0 241 229 604	B5HS	
0 241 229 612	B5HS	
0 241 229 617	BP5EFS	
0 241 229 619	BP5ET	
0 241 229 634	BCP5ES	
0 241 229 639	ZFR5F	
0 241 229 641	BP5HS	
0 241 229 649	BP5EFS	
0 241 229 657	ZFR5F	

BOSCH	→ NGK	Quick
0 241 229 661	BUR6ET	
0 241 229 663	BUR5ET-10	
0 241 229 665	BUR5ET	
0 241 229 666	BKR6EK	
0 241 229 676	BKUR5ET	
0 241 229 682	BCP5ES-11	
0 241 229 684	BKR5ES	
0 241 229 704	IFR5D10	
0 241 229 712	BCP5ES	
0 241 229 713	BCP5ES	
0 241 229 714	BP5HS	
0 241 229 715	BP5ES	
0 241 229 716	BP5ET	
0 241 229 926	BP5ES	
0 241 235 089	B6ES	
0 241 235 098	B6ES	
0 241 235 099	BPR6ES	
0 241 235 103	BP6ESZ	
0 241 235 108	BCP6ET	
0 241 235 563	BP6ES	
0 241 235 564	BP6HS	
0 241 235 566	BM6A	Q303
0 241 235 567	BPM6A	Q304
0 241 235 574	B6ES	
0 241 235 585	BP6HS-10	
0 241 235 594	B6S	Q302
0 241 235 602	BP6ES	
0 241 235 607	B6HS-5	
0 241 235 610	BP6ES-11	
0 241 235 619	B6HS-5	
0 241 235 623	BP6S	
0 241 235 633	BUR6ET	
0 241 235 635	BP6EFS	
0 241 235 636	BP6EFS	
0 241 235 638	BR6EF	
0 241 235 643	BUR6ET	
0 241 235 646	BP6EFS-13	
0 241 235 668	BP6EFS	
0 241 235 673	BCP6ES	
0 241 235 674	ZFR6A-11	
0 241 235 676	BCP6ES	
0 241 235 681	BP6EFS	
0 241 235 685	BCP6ES-11	
0 241 235 690	BKR6EK	
0 241 235 692	ZFR6F-11	
0 241 235 693	BP6ESZ	
0 241 235 698	BUR6ET	
0 241 235 705	BP6ESZ	
0 241 235 706	BKUR6ET-10	
0 241 235 706	BKUR6ET-10	
0 241 235 715	PZFR5D-11	
0 241 235 735	ZFR5P-G	

BOSCH	→ NGK	Quick
0 241 235 736	BKR6ES	
0 241 235 739	IFR6D10	
0 241 235 750	BCP6ES	
0 241 235 751	BKR6EK	
0 241 235 752	BKUR6ET-10	
0 241 235 752	BKUR6ET-10	
0 241 235 753	BP6EFS	
0 241 235 754	BP6HS	
0 241 235 755	BP6ES	
0 241 235 756	BUR6ET	
0 241 235 757	BUR6ET	
0 241 240 057	BP6ESZ	
0 241 240 058	BP6ESZ	
0 241 240 524	BP6EFS	
0 241 240 530	BP6ES	
0 241 240 532	BP6HS	
0 241 240 539	BP6ES	
0 241 240 542	BCP6ES	
0 241 240 543	BP6FS	
0 241 240 558	BUR6ET	
0 241 240 563	BP6EFS	
0 241 240 564	BCP6ET	
0 241 240 569	BCP6ES-11	
0 241 240 574	BP6ES-11	
0 241 240 578	BP6EFS	
0 241 240 585	BKR6EIX	
0 241 240 587	BKR6ES	
0 241 240 592	BKUR7ET	
0 241 240 600	BM6A	Q303
0 241 240 601	BPM6A	Q304
0 241 240 603	B6HS	Q203
0 241 240 608	BCP6ES	
0 241 240 609	BCP6ET	
0 241 240 611	BP6ES	
0 241 240 631	ILFR6A	
0 241 243 501	BPR6EIX	
0 241 245 070	BUR6ET	
0 241 245 539	BM7F	
0 241 245 552	BP7ES	Q206
0 241 245 553	BP7HS	
0 241 245 554	BM7A	
0 241 245 555	BPM7A	Q305
0 241 245 570	BP7EFS	
0 241 245 574	BR7HIX	
0 241 245 575	BR7EIX	
0 241 245 580	B7HS	Q204
0 241 245 581	B7ES	
0 241 245 592	B7S	
0 241 245 599	BP7ES	Q206
0 241 245 602	B7HS	Q204
0 241 245 603	B7ES	
0 241 245 619	BP7HS	

BOSCH	→ NGK	Quick
0 241 245 636	BP7EFS	
0 241 245 641	PFR7B	
0 241 245 642	BCP7ES	
0 241 245 646	BP7HS-10	
0 241 245 655	BCP7ES	
0 241 245 656	BP7HS	
0 241 245 673	PLFER7A8EG	
0 241 247 500	BPR7EIX	
0 241 248 531	B8HS	Q205
0 241 248 534	B8ES	Q201
0 241 248 538	B8ES	Q201
0 241 248 540	B8HS	Q205
0 241 250 502	BPR8EIX	
0 241 250 512	BPR8EIX	
0 241 250 526	R7433-8	
0 241 252 521	BR8HIX	
0 241 252 522	BR8EIX	
0 241 255 505	B8EFS	
0 241 255 507	R7433-9	
0 241 256 512	B8HS	Q205
0 241 256 513	B9ES	Q202
0 241 256 514	BR8HIX	
0 241 256 515	BR9EIX	
0 241 256 517	BPR8EIX	
0 241 256 519	B8HS	Q205
0 241 256 522	B9ES	Q202
0 241 260 507	B9HS	
0 241 260 508	B10ES	
0 241 260 510	B9EFS	
0 241 260 512	R7433-9	
0 241 262 505	BR9HIX	
0 241 262 506	BR10EIX	
0 241 268 505	BR9HIX	
0 241 268 506	BR10EIX	
0 241 274 504	BR10HIX	
0 241 274 505	BR10EIX	
0 241 280 503	BR10EIX	
0 241 309 501	AP5FS	
0 241 319 510	AP5FS	
0 241 319 512	AB-6	
0 241 319 513	AB-6	
0 241 325 509	AP5FS	
0 241 329 520	AP5FS	
0 241 329 525	AB-6	
0 241 329 526	AB-6	
0 241 335 516	AP6FS	
0 241 335 520	A6FS	
0 241 335 524	AB-7	
0 241 335 526	AB-7	
0 241 335 528	AP6FS	
0 241 340 501	AP6FS	
0 241 345 512	AB-7	



BOSCH	→ NGK	Quick
0 241 350 505	AB-7	
0 242 035 500	CMR6H	
0 242 040 500	CR6HS	Q223
0 242 050 500	CR6HS	Q223
0 242 055 500	CR7HS	
0 242 055 501	CR7HSA	
0 242 055 502	CR7E	Q225
0 242 055 505	CR7HSA	
0 242 060 500	CR8HS	
0 242 060 501	CR8E	Q226
0 242 129 503	LZKAR7A	
0 242 129 508	LZKAR7A	
0 242 129 512	PLZKBR7B8DG	
0 242 129 804	PLZKBR7B8DG	
0 242 135 500	DPR7EA-9	Q220
0 242 135 501	DCPR8E-N	
0 242 135 509	PLKR7A	
0 242 135 515	ZKR7A-10	
0 242 135 518	PLZKBR7B8DG	
0 242 140 500	DR7EA	
0 242 140 504	DCPR8EKC	
0 242 140 512	PLKR7B8E	
0 242 140 528	ILZKR7A	
0 242 140 557	ILKAR8H6	
0 242 145 500	DPR7EA-9	Q220
0 242 145 501	DPR7EA-9	Q220
0 242 145 503	DCPR8EKC	
0 242 145 504	KR9CI	
0 242 145 516	DPR7EA-9	Q220
0 242 145 517	SILZKBR8D8S	
0 242 150 500	DR8HS	
0 242 150 501	DR8ES	Q217
0 242 150 505	DPR8EA-9	Q221
0 242 160 501	DR8ES	Q217
0 242 215 502	BR4-LM	
0 242 219 004	BR4HS	
0 242 219 511	BPR4FS-15	
0 242 219 512	BP-4	
0 242 219 513	BP-4	
0 242 219 514	BR5FS	
0 242 219 515	BR5FS	
0 242 219 516	BPR4FS	
0 242 219 517	BPR4FS-11	
0 242 219 519	BCPR4ES-11	
0 242 219 520	BP-4	
0 242 219 529	ZGR5B	
0 242 219 530	BPR4ES-13	
0 242 225 522	BR6S	
0 242 225 523	BR5ES	
0 242 225 524	BPR5ES	
0 242 225 525	BPR5ES-13	
0 242 225 526	BP5S	

BOSCH	→ NGK	Quick
0 242 225 527	BP5S	
0 242 225 528	ZGR5C	
0 242 225 529	BR5FS	
0 242 225 530	BR5FS	
0 242 225 531	BPR4FS	
0 242 225 532	BPR4FS-15	
0 242 225 533	BPR5EFS	
0 242 225 534	BPR5EFS-13	
0 242 225 536	BR6S	
0 242 225 537	ZFR4F-11	
0 242 225 538	BPR5EIX	
0 242 225 539	ZGR5A	
0 242 225 548	BPR5ES-11	
0 242 225 549	BCPR4ES-11	
0 242 225 550	BPR5ES	
0 242 225 553	BPR5ES	
0 242 225 554	BPR5ES-11	
0 242 225 560	BPR4FS-11	
0 242 225 563	BP5S	
0 242 225 564	BP5S	
0 242 225 566	BPR4FS-15	
0 242 225 571	TR5IX	
0 242 225 573	BPR4FS	
0 242 225 578	TR55IX	
0 242 225 582	BKR5ES	
0 242 225 599	BPR5ES	
0 242 225 599	BPR5ES	
0 242 225 612	BMR4A	Q306
0 242 225 622	BPR4FS	
0 242 225 623	TR55	
0 242 225 624	BPR5ES-11	
0 242 225 641	BPR4FS-15	
0 242 225 859	BPR5ES	
0 242 225 861	BPR5ES	
0 242 229 524	BR6S	
0 242 229 525	BP5S	
0 242 229 526	BR5FS	
0 242 229 528	BPR5FS	
0 242 229 529	BPR5FS-15	
0 242 229 530	BKR5ES-11	
0 242 229 531	BPR5ES	
0 242 229 533	BR5ES	
0 242 229 534	BR5HS	
0 242 229 537	BPR5EIX	
0 242 229 538	BPR5ES	
0 242 229 543	BKR5ES-11	
0 242 229 544	ZFR5F-11	
0 242 229 548	BPR5FS	
0 242 229 549	BPR5FS-11	
0 242 229 555	BPR5ES	
0 242 229 556	BR5ES	
0 242 229 557	BPR5ES-11	



BOSCH	→ NGK	Quick
0 242 229 566	BPR5ES-11	
0 242 229 568	BKR5ES	
0 242 229 570	BPR5ES	
0 242 229 576	ZFR6F-11	
0 242 229 587	BKR5ES	
0 242 229 589	BPR5HS	
0 242 229 591	BKR5EK	
0 242 229 594	BKR5ES	
0 242 229 598	BKR5EIX	
0 242 229 605	BKR5EK	
0 242 229 607	BPR5ES	
0 242 229 610	BPR5HS	
0 242 229 613	BKR5EKUP	
0 242 229 625	BKUR5ET-10	
0 242 229 626	BKR5EK	
0 242 229 628	BKR5EK	
0 242 229 630	LFR5B	
0 242 229 630	LFR5B	
0 242 229 634	PLFR5A-11	
0 242 229 635	BKR5EYA-11	
0 242 229 641	PTR5D-10	
0 242 229 648	BKR5EQUPA	
0 242 229 650	TR5B-13	
0 242 229 654	BKR5EK	
0 242 229 655	BPR5EFS	
0 242 229 655	BPR5EFS	
0 242 229 656	BPR5ES	
0 242 229 656	BPR5ES	
0 242 229 657	BPR5HS	
0 242 229 657	BPR5HS	
0 242 229 658	BUR5ET-10	
0 242 229 659	BKR5ES	
0 242 229 660	BKR5ES-11	
0 242 229 661	LTR6B-10T	
0 242 229 671	BKR5EKB-11	
0 242 229 673	BKR5ES	
0 242 229 687	BPR5ES-11	
0 242 229 699	ZFR5F	
0 242 229 706	BKUR5ET-10	
0 242 229 708	ILFR5B11	
0 242 229 713	PFR5R-11	
0 242 229 724	BKR6EZB	
0 242 229 779	ZGR5A	
0 242 229 781	BKR5EKB-11	
0 242 229 782	BKR5EKB-11	
0 242 229 785	TR5B-13	
0 242 229 797	LFR6B	
0 242 229 797	LFR6B	
0 242 229 799	BKUR5ET-10	
0 242 229 878	BKR5EK	
0 242 229 879	BPR5EFS	
0 242 229 880	BPR5ES	

BOSCH	→ NGK	Quick
0 242 229 881	BPR5HS	
0 242 229 882	BUR5ET-10	
0 242 229 883	BKR5ES	
0 242 229 884	BKR5ES-11	
0 242 229 885	BPR5ES-11	
0 242 229 887	BKR5EK	
0 242 229 888	BKR5ES	
0 242 229 902	TR5B-13	
0 242 229 923	LFR6B	
0 242 229 923	LFR6B	
0 242 229 925	PFR5R-11	
0 242 229 982	BPR5ES	
0 242 230 500	PFR5R-11	
0 242 230 806	ZFR5F	
0 242 235 511	BPR6ES	
0 242 235 522	BPR6HS	
0 242 235 522	BPR6HS	Q214
0 242 235 522	BPR6HS	
0 242 235 525	BPR6EIX	
0 242 235 529	BPR6ES	
0 242 235 530	BPR6ES-11	
0 242 235 532	BR6ES	
0 242 235 533	BR6HS	Q209
0 242 235 535	BPR6HS	
0 242 235 535	BPR6HS	Q214
0 242 235 535	BPR6HS	
0 242 235 537	BPR6ES	
0 242 235 538	BPR6EFS	
0 242 235 541	BPR6EIX	
0 242 235 542	BPR6EFS	
0 242 235 543	BR6ES-11	
0 242 235 544	BKR6ES-11	
0 242 235 545	BR6ES-11	
0 242 235 546	BR6ES	
0 242 235 547	BKR6ES-11	
0 242 235 551	BKR6ES	
0 242 235 554	BR6S	
0 242 235 556	BKR6ES	
0 242 235 564	BCPR6ET	
0 242 235 567	ZFR6F-11	
0 242 235 571	BUR6ET	
0 242 235 577	BPR6EFS-15	
0 242 235 579	BKR6ES	
0 242 235 587	BKR6ES	
0 242 235 588	BKR6ES	
0 242 235 589	BKR6EK	
0 242 235 590	BUR6ET	
0 242 235 592	BPR6EFS-13	
0 242 235 597	BKR6ES	
0 242 235 599	BKR6EY	
0 242 235 602	BKR6EY-11	
0 242 235 605	BKR6EK	



BOSCH	→ NGK	Quick
0 242 235 607	BUR6EFSZ	
0 242 235 609	BKR6EZ	
0 242 235 610	BKR6EP-13	
0 242 235 616	BKR6ES	
0 242 235 617	BKR6EQUP	
0 242 235 624	BKR6ES	
0 242 235 630	BPR6ES	
0 242 235 636	LFR6A	
0 242 235 640	BKR6EZ	
0 242 235 642	BKR6EKUB	
0 242 235 651	BPMR6A	Q308
0 242 235 656	BKR6EQUP	
0 242 235 659	BKR6EYA-11	
0 242 235 661	BPR6EFS	
0 242 235 661	BPR6EFS	
0 242 235 662	PTR5A-13	
0 242 235 663	BPR6ES	
0 242 235 663	BPR6ES	
0 242 235 664	BUR6ET	
0 242 235 665	BPR6HS	
0 242 235 665	BPR6HS	Q214
0 242 235 665	BPR6HS	
0 242 235 665	BPR6HS	Q214
0 242 235 665	BPR6HS	
0 242 235 666	BKR6ES	
0 242 235 667	BKR6ES-11	
0 242 235 668	BKR6EKC	
0 242 235 668	BKR6EKC	
0 242 235 690	PFR6N-11	
0 242 235 692	ZFR5E-11	
0 242 235 699	BKR6EIX	
0 242 235 707	BPR6ES-11	
0 242 235 715	BKR6EQUA	
0 242 235 740	PFR6Q	
0 242 235 743	PLFR6A	
0 242 235 748	BKR6EKUB	
0 242 235 749	PFR6B	
0 242 235 761	ZFR5P-G	
0 242 235 767	PTR5A-13	
0 242 235 767	PTR5A-13	
0 242 235 769	ILZFR6C-11K	
0 242 235 776	IZFR6H11	
0 242 235 908	BPR6EFS	
0 242 235 909	BPR6ES	
0 242 235 910	BUR6ET	
0 242 235 911	BPR6HS	
0 242 235 911	BPR6HS	Q214
0 242 235 911	BPR6HS	
0 242 235 912	BKR6ES	
0 242 235 913	BKR6ES-11	
0 242 235 914	BKR6EKC	

BOSCH	→ NGK	Quick
0 242 235 915	BPR6ES-11	
0 242 235 916	PTR5A-13	
0 242 235 917	BKR6EKUB	
0 242 235 918	PFR6B	
0 242 235 925	BKR6ES	
0 242 235 930	BPR6ES	
0 242 235 931	BUR6ET	
0 242 235 979	BPR6EFS-13	
0 242 235 980	BKR6EY	
0 242 235 981	BKR6EQUP	
0 242 235 982	PFR6Q	
0 242 235 983	ZFR6T-11G	
0 242 235 984	PZFR5D-11	
0 242 235 985	BKR6EY-11	
0 242 235 986	ZFR6F-11	
0 242 236 510	ILZFR6D11	
0 242 236 528	ILFR6B	
0 242 236 541	BKR6EY-11	
0 242 236 542	ZFR6F-11	
0 242 236 543	BPR6EFS-15	
0 242 236 560	BPR6EFS-13	
0 242 236 561	BKR6EY	
0 242 236 562	BKR6EQUP	
0 242 236 564	PFR6Q	
0 242 236 565	ZFR6T-11G	
0 242 236 566	PZFR5D-11	
0 242 236 571	LPG1	
0 242 236 577	ILFR6K8	
0 242 236 583	PFR6X-11	
0 242 236 610	DIFR6A13G	
0 242 236 653	LZFR6AP11GS	
0 242 236 673	DILFR6A11	
0 242 240 511	BPR6ES	
0 242 240 514	BPR6EFS	
0 242 240 516	BPR6EIX	
0 242 240 519	BPR6EFS	
0 242 240 520	BPR6FS	
0 242 240 521	BPR6ES	
0 242 240 522	BPR6EFS	
0 242 240 526	BKR6ES	
0 242 240 528	BCPR6ET	
0 242 240 530	BKR6ES	
0 242 240 531	BPR6ES-11	
0 242 240 532	BPR6ES-11	
0 242 240 533	BKR6ES-11	
0 242 240 539	BKR6ES-11	
0 242 240 546	BUR6ET	
0 242 240 547	BKR5EKC	
0 242 240 557	BKR6EK	
0 242 240 561	BPR6HS	
0 242 240 561	BPR6HS	Q214
0 242 240 561	BPR6HS	



BOSCH	→ NGK	Quick
0 242 240 562	BKR6EZ	
0 242 240 564	BKR7EKC	
0 242 240 565	BKR7EKC	
0 242 240 566	BKR6EK	
0 242 240 569	BUR6EFSZ	
0 242 240 572	BKUR6ET	
0 242 240 579	BPR6ES	
0 242 240 582	BMR6A	Q307
0 242 240 584	BKR6EKE	
0 242 240 587	BKR6EQUP	
0 242 240 590	ZFR6S-Q	
0 242 240 591	BPR6EFS	
0 242 240 591	BPR6EFS	
0 242 240 592	BPR6ES	
0 242 240 592	BPR6ES	
0 242 240 593	BKR6ES	
0 242 240 593	BKR6ES	
0 242 240 605	BKR6ES	
0 242 240 619	ILFR6A	
0 242 240 648	BKR6EZ	
0 242 240 653	LPG1	
0 242 240 665	PZFR6R	
0 242 240 848	BPR6EFS	
0 242 240 849	BPR6ES	
0 242 240 850	BKR6ES	
0 242 240 851	BKR6ES	
0 242 245 015	BPR7EIX	
0 242 245 018	BKR7EKC	
0 242 245 514	BPR7EIX	
0 242 245 515	BCPR7ES	
0 242 245 517	BR7HS	Q211
0 242 245 519	BPR7ES	
0 242 245 520	BCPR7ES	
0 242 245 521	BR7ES	
0 242 245 536	BCPR7ES	
0 242 245 537	BPR7ES	
0 242 245 539	BCPR7ET	
0 242 245 550	BCPR7ES-11	
0 242 245 552	BPR7ES	
0 242 245 552	BPR7ES	
0 242 245 557	BR7ES	
0 242 245 559	BKR7EQUP	
0 242 245 571	LPG1	
0 242 245 576	PFR7S8EG	
0 242 245 812	BPR7ES	
0 242 250 503	BR8ES	Q207
0 242 250 506	BR8HS	Q212
0 242 250 517	BR8EIX	
0 242 255 501	BR9ET	
0 242 255 502	BR9ES	Q208
0 242 255 504	BR9EIX	
0 242 260 001	BR10ES	

BOSCH	→ NGK	Quick
0 242 319 501	APR5FS	
0 242 325 501	APR5FS	
0 242 329 503	APR5FS	
0 242 335 504	APR6FS	
0 242 340 501	APR6FS	
F 000 KE0 017	BKUR6ET-10	
F 000 KE0 017	BKUR6ET-10	
F 000 KE0 P34	BPR6ES	
F 000 KE0 P40	BKR6ES-11	
F 000 KE0 P41	BKR5ES-11	
F 5KP P33 2GF	PFR8S8EG	
U 6 AC	CR4HSA	
U 5 AC	C5HSA	
U 5 AC	C5HSA	
U 5 AC	C5HSA	
U 4 AC	C6HSA	
U 3 CC	C7E	
Y 6 DC	DCP6E	
X 5 DC	DP7EA-9	
X 5 DC	DP7EA-9	
X 5 DC	DP7EA-9	
X 5 CC	D8EA	Q216
Y 5 KPP 332 S	PZKER7A8EGS	
X 4 CS	D8EA	Q216
WEA	BUH	
W 12 A	B-4H	
W 10 FC	BP-4	
H 10 BC	BP4FS	
W 10 AC	B-4H	
W 10 CC	B4ES	
W 10 DC	BP4ES	
W 10 AC	B-4H	
W 10 EC	B-4	
W 10 DC	BP4ES	
W 9 DC0	BP5ES	
H 9 BC	BP4FS	
W 9 DC	BP5ES	
W 9 CC	B4ES	
W 9 EC	B-4	
W 9 AC	B5HS	
W 9 DC	BP5ES	
W 9 EC0	B4-LM	Q301
H 9 BCY	BPR4FS-15	
W 9 DC	BP5ES	
H 9 DC	BP5EFS	
H 9 DC0	BP5EFS	
F 9 DC 0	BCPR4ES-11	
W 9 DTC	BP5ET	
W 9 DCX	BP5ES-11	
W 9 LC	ZGR5A	
WS 9 EC	BM4A	
W 9 EC0	B4-LM	Q301



BOSCH	→ NGK	Quick
W 9 DC	BP5ES	
W 8 LCR	ZGR5A	
W 8 DC0	BP5ES	
W 8 DC0	BP5ES	
HS 8 E	BM6F	
WS 8 E	BM6A	Q303
WS 8 F	BPM6A	Q304
W 8 DC	BP5ES	
W 8 BC	BP5HS	
W 8 CC	B5ES	
W 8 EC	B6S	Q302
W 8 DC	BP5ES	
W 8 FC	BP5S	
H 8 BC	BP5FS	
W 8 DCX	BP5ES-11	
W 8 AC	B5HS	
W 8 AC	B5HS	
H 8 DC	BP5EFS	
W 8 DTC	BP5ET	
F 8 DC	BCP5ES	
F 8 LCR	ZFR5F	
W 8 BC	BP5HS	
H 8 DC 0	BP5EFS	
F 8 LCR 2	ZFR5F	
W 8 LDCR	BUR6ET	
W 8 LTCR	BUR5ET-10	
W 8 LTCR	BUR5ET	
F 8 LDCR	BKR6EK	
F 8 KTCR	BKUR5ET	
F 8 DCX	BCP5ES-11	
F 8 DC0R	BKR5ES	
F 8 DPP 332	IFR5D10	
F 8 DC	BCP5ES	
F 8 DC 4	BCP5ES	
W 8 BC	BP5HS	
W 8 DC	BP5ES	
W 8 DTC	BP5ET	
W 8 DC	BP5ES	
W 7 CC	B6ES	
W 7 CC0	B6ES	
W 7 DCR	BPR6ES	
W 7 DC0	BP6ESZ	
F 7 DTC	BCP6ET	
W 7 DC	BP6ES	
W 7 BC	BP6HS	
WS 7 E	BM6A	Q303
WS 7 F	BPM6A	Q304
W 7 CC	B6ES	
W 7 EC	B6S	Q302
W 7 DC	BP6ES	
W 7 AC	B6HS-5	
W 7 DCX	BP6ES-11	

BOSCH	→ NGK	Quick
W 7 AC	B6HS-5	
W 7 FC	BP6S	
H 7 DC	BP6EFS	
H 7 DC	BP6EFS	
H 7 CC	BR6EF	
H 7 DCY	BP6EFS-13	
H 7 DC 0	BP6EFS	
F 7 DC	BCP6ES	
F 7 LCR	ZFR6A-11	
F 7 DC 0	BCP6ES	
H 7 DC 0	BP6EFS	
F 7 DCX	BCP6ES-11	
F 7 LDCR	BKR6EK	
F 7 LC0R 2	ZFR6F-11	
W 7 DC0	BP6ESZ	
W 7 LTCR	BUR6ET	
W 7 DC0	BP6ESZ	
F 7 KTCR	BKUR6ET-10	
F 7 KTCR	BKUR6ET-10	
F 7 HPP 222	PZFR5D-11	
F 7 HER 2	ZFR5P-G	
F 7 DER	BKR6ES	
F 7 DPP 332	IFR6D10	
F 7 DC	BCP6ES	
F 7 LDCR	BKR6EK	
F 7 LTCR	BKUR6ET-10	
F 7 LTCR	BKUR6ET-10	
H 7 DC	BP6EFS	
W 7 BC	BP6HS	
W 7 DC	BP6ES	
W 7 DTC	BUR6ET	
W 7 LTCR	BUR6ET	
W 6 DC0	BP6ESZ	
W 6 DC0	BP6ESZ	
H 6 DC	BP6EFS	
W 6 BC	BP6HS	
H 6 BC	BP6FS	
W 6 DTC	BUR6ET	
H 6 DC	BP6EFS	
F 6 DCX	BCP6ES-11	
W 6 DCX	BP6ES-11	
H 6 DC 0	BP6EFS	
F 6 DSR	BKR6EIX	
F 6 DCOR	BKR6ES	
F 6 LTCR	BKUR7ET	
WS 6 E	BM6A	Q303
WS 6 F	BPM6A	Q304
W 6 AC	B6HS	Q203
F 6 DC	BCP6ES	
F 6 DTC	BCP6ET	
W 6 DC	BP6ES	
F 6 MPP 332	ILFR6A	



BOSCH	→ NGK	Quick
W 6 DP0	BPR6EIX	
W 5 DTC	BUR6ET	
HS 5 E	BM7F	
W 5 DC	BP7ES	Q206
WS 5 E	BM7A	
WS 5 F	BPM7A	Q305
H 5 DC	BP7EFS	
W 5 AS	BR7HIX	
W 5 CS	BR7EIX	
W 5 AC	B7HS	Q204
W 5 CC	B7ES	
W 5 EC	B7S	
W 5 DC	BP7ES	Q206
W 5 AC	B7HS	Q204
W 5 CC	B7ES	
H 5 DC 0	BP7EFS	
F 5 DP 0 R	PFR7B	
F 5 DC	BCP7ES	
W 5 BC	BP7HS	
FQ 5 NPP 332 S	PLFER7A8EG	
W 5 DP0	BPR7EIX	
W 4 AC	B8HS	Q205
W 4 CC	B8ES	Q201
W 4 CC	B8ES	Q201
W 4 AC	B8HS	Q205
W 4 DP0	BPR8EIX	
W 4 DP0	BPR8EIX	
F 4 CS	R7433-8	
W 4 AS	BR8HIX	
W 4 CS	BR8EIX	
H 3 CS	B8EFS	
F 3 CS	R7433-9	
W 3 AC	B8HS	Q205
W 3 CC	B9ES	Q202
W 3 AS	BR8HIX	
W 3 CS	BR9EIX	
W 3 DP0	BPR8EIX	
W 3 AC	B8HS	Q205
W 3 CC	B9ES	Q202
W 2 AC	B9HS	
W 2 CC	B10ES	
H 2 CS	B9EFS	
F 2 CS	R7433-9	
W 2 AS	BR9HIX	
W 2 CS	BR10EIX	
W 08 AS	BR9HIX	
W 08 CS	BR10EIX	
W 07 AS	BR10HIX	
W 07 CS	BR10EIX	
W 06 CS	BR10EIX	
M 12 B	AP5FS	
D 10 BC	AP5FS	

BOSCH	→ NGK	Quick
M 10 AC0	AB-6	
M 10 AC	AB-6	
D 9 BC	AP5FS	
D 8 BC	AP5FS	
M 8 AC0	AB-6	
M 8 AC	AB-6	
D 7 AC	A6FS	
M 7 AC	AB-7	
M 7 AC	AB-7	
D 7 BC	AP6FS	
D 6 BC	AP6FS	
M 5 AC	AB-7	
M 4 AC	AB-7	
USR 7 AC	CMR6H	
UR 6 AC	CR6HS	Q223
UR 4 AS	CR6HS	Q223
UR 3 AS	CR7HS	
UR 3 AC	CR7HSA	
UR 3 CC	CR7E	Q225
UR 3 AC	CR7HSA	
UR 2 AS	CR8HS	
UR 2 CC	CR8E	Q226
VR 8 SE	LZKAR7A	
VR 8 SEW	LZKAR7A	
ZQR 8 SI 302	PLZKBR7B8DG	
ZQR 8 SI 302	PLZKBR7B8DG	
XR 7 LDC	DPR7EA-9	Q220
YR 7 DE	DCPR8E-N	
YR 7 MPP 33	PLKR7A	
YR 7 DC+	ZKR7A-10	
ZR 7 SI 332 S	PLZKBR7B8DG	
XR 6 CC	DR7EA	
YR 6 LDE	DCPR8EKC	
YR 6 NPP 332	PLKR7B8E	
YR 6 TII 330 T	ILZKR7A	
VR 6 NII 332	ILKAR8H6	
XR 5 DC	DPR7EA-9	Q220
YR 5 LDE	DCPR8EKC	
YR 5 DDE	KR9CI	
XR 5 DC	DPR7EA-9	Q220
ZMR 5 TPP 33	SILZKBR8D8S	
XR 4 AS	DR8HS	
XR 4 CS	DR8ES	Q217
XR 4 DC	DPR8EA-9	Q221
XR 2 CS	DR8ES	Q217
WR 11 E 0	BR4-LM	
WR 10 AC	BR4HS	
HR 10 BCY	BPR4FS-15	
WR 10 FC	BP-4	
WR 10 FCY	BP-4	
HR 10 AC	BR5FS	
HR 10 ACY	BR5FS	



BOSCH	→ NGK	Quick
HR 10 BC	BPR4FS	
HR 10 BCX	BPR4FS-11	
FR 10 DCX	BCPR4ES-11	
WR 10 FC	BP-4	
WR 10 LC	ZGR5B	
WR 10 LCV	BPR4ES-13	
WR 9 EC	BR6S	
WR 9 CC	BR5ES	
WR 9 DC	BPR5ES	
WR 9 DCY	BPR5ES-13	
WR 9 FC	BP5S	
WR 9 FCY	BP5S	
WR 9 HC	ZGR5C	
HR 9 AC	BR5FS	
HR 9 ACY	BR5FS	
HR 9 BC	BPR4FS	
HR 9 BCY	BPR4FS-15	
HR 9 DC	BPR5EFS	
HR 9 DCX	BPR5EFS-13	
WR 9 EC0	BR6S	
FR 9 HC	ZFR4F-11	
WR 9 DS	BPR5EIX	
WR 9 LS	ZGR5A	
WR 9 DCX	BPR5ES-11	
FR 9 DCX	BCPR4ES-11	
WR 9 DC	BPR5ES	
WR 9 DP	BPR5ES	
WR 9 DPX	BPR5ES-11	
HR 9 BPX	BPR4FS-11	
WR 9 FP	BP5S	
WR 9 FPY	BP5S	
HR 9 BPY	BPR4FS-15	
HR 9 DPX	TR5IX	
HR 9 BP	BPR4FS	
HR 9 DPY	TR55IX	
FR 9 DC	BKR5ES	
WR 9 D+	BPR5ES	
WR 9 DC+	BPR5ES	
WSR 9 EC	BMR4A	Q306
HR 9 BC+	BPR4FS	
HR 9 DCY+	TR55	
WR 9 DCX+	BPR5ES-11	
HR 9 BCY+	BPR4FS-15	
WR 9 DC+	BPR5ES	
WR 9 DC+	BPR5ES	
WR 8 EC	BR6S	
WR 8 FC	BP5S	
HR 8 AC	BR5FS	
HR 8 BC	BPR5FS	
HR 8 BCY	BPR5FS-15	
FR 8 DCX	BKR5ES-11	
WR 8 DC	BPR5ES	

BOSCH	→ NGK	Quick
WR 8 CC	BR5ES	
WR 8 AC	BR5HS	
WR 8 DS	BPR5EIX	
WR 8 DC	BPR5ES	
FR 8 DPX	BKR5ES-11	
FR 8 HP	ZFR5F-11	
HR 8 BP	BPR5FS	
HR 8 BPX	BPR5FS-11	
WR 8 DP	BPR5ES	
WR 8 CP	BR5ES	
WR 8 DPX	BPR5ES-11	
WR 8 DCX	BPR5ES-11	
FR 8 DC	BKR5ES	
WR 8 DC	BPR5ES	
FR 8 LCX	ZFR6F-11	
FR 8 DC	BKR5ES	
WR 8 BC	BPR5HS	
FR 8 LDC	BKR5EK	
FR 8 DC 0	BKR5ES	
FR 8 DS	BKR5EIX	
FR 8 LDC	BKR5EK	
WR 8 DC4	BPR5ES	
WR 8 BC	BPR5HS	
FGR 8 KQE	BKR5EKUP	
FR 8 LTC	BKUR5ET-10	
FLR 8 LDCU	BKR5EK	
FR 8 KDC	BKR5EK	
FR 8 ME	LFR5B	
FR 8 ME	LFR5B	
FGR 8 MQPE	PLFR5A-11	
FR 8 KCU	BKR5EYA-11	
HR 8 DPP 22U	PTR5D-10	
FGR 8 KQE 0	BKR5EQUA	
HR 8 MEV	TR5B-13	
FLR 8 LDCU+	BKR5EK	
HR 8 D+	BPR5EFS	
HR 8 DC+	BPR5EFS	
WR 8 D+	BPR5ES	
WR 8 DC+	BPR5ES	
WR 8 B+	BPR5HS	
WR 8 BC+	BPR5HS	
WR 8 LTC+	BUR5ET-10	
FR 8 DC+	BKR5ES	
FR 8 DCX+	BKR5ES-11	
HLR 8 STEX	LTR6B-10T	
FR 8 HDC	BKR5EKB-11	
FR 8 DE	BKR5ES	
WR 8 DCX+	BPR5ES-11	
FQR 8 LEU 2	ZFR5F	
FR 8 KTC	BKUR5ET-10	
FR 8 SPP 332	ILFR5B11	
FR 8 DPP 33	PFR5R-11	



BOSCH	→ NGK	Quick
FQR 8 DE	BKR6EZB	
WR 8 LC+	ZGR5A	
FR 8 HDC+	BKR5EKB-11	
HR 8 MCV+	TR5B-13	
FR 8 SC+	LFR6B	
FR 8 SC+	LFR6B	
FR 8 KTC+	BKUR5ET-10	
FLR 8 LDCU+	BKR5EK	
HR 8 DC+	BPR5EFS	
WR 8 DC+	BPR5ES	
WR 8 BC+	BPR5HS	
WR 8 LTC+	BUR5ET-10	
FR 8 DC+	BKR5ES	
FR 8 DCX+	BKR5ES-11	
WR 8 DCX+	BPR5ES-11	
FLR 8 LDCU+	BKR5EK	
FR 8 DC+	BKR5ES	
HR 8 MCV+	TR5B-13	
FR 8 SC+	LFR6B	
FR 8 SC+	LFR6B	
FR 8 DPP 33+	PFR5R-11	
WR 8 DC+	BPR5ES	
FR 8 DPP 33+	PFR5R-11	
FQR 8 LEU 2	ZFR5F	
WR 7 DC	BPR6ES	
WR 7 BC	BPR6HS	
WR 7 BC	BPR6HS	Q214
WR 7 BC	BPR6HS	
WR 7 DS	BPR6EIX	
WR 7 DC	BPR6ES	
WR 7 DCX	BPR6ES-11	
WR 7 CC	BR6ES	
WR 7 AC	BR6HS	Q209
WR 7 BP	BPR6HS	
WR 7 BP	BPR6HS	Q214
WR 7 BP	BPR6HS	
WR 7 DC	BPR6ES	
HR 7 DC	BPR6EFS	
WR 7 DP	BPR6EIX	
HR 7 DC	BPR6EFS	
WR 7 CCX	BR6ES-11	
FR 7 DCX	BKR6ES-11	
WR 7 CPX	BR6ES-11	
WR 7 CP	BR6ES	
FR 7 DPX	BKR6ES-11	
FR 7 DC	BKR6ES	
WR 7 EC	BR6S	
FR 7 DP	BKR6ES	
FR 7 DTC	BCPR6ET	
FR 7 LCX	ZFR6F-11	
WR 7 DTC	BUR6ET	
HR 7 DCY	BPR6EFS-15	

BOSCH	→ NGK	Quick
FR 7 DC	BKR6ES	
FR 7 DC 2	BKR6ES	
FR 7 LC 2	BKR6ES	
FR 7 LDC	BKR6EK	
WR 7 DTC	BUR6ET	
HR 7 DCX	BPR6EFS-13	
FR 7 DC 0	BKR6ES	
FR 7 KC	BKR6EY	
FR 7 KCX	BKR6EY-11	
FR 7 LDC	BKR6EK	
HGR 7 KQC	BUR6EFSZ	
FR 7 KDC	BKR6EZ	
FR 7 KCW	BKR6EP-13	
FR 7 DC 4	BKR6ES	
FGR 7 DQP	BKR6EQUP	
FR 7 DC 2	BKR6ES	
WR 7 DC2	BPR6ES	
FR 7 ME	LFR6A	
FR 7 DE	BKR6EZ	
FGR 7 DQE0	BKR6EKUB	
WSR 7 F	BPMR6A	Q308
FGR 7 KQE	BKR6EQUP	
FR 7 KCU	BKR6EYA-11	
HR 7 D+	BPR6EFS	
HR 7 DC+	BPR6EFS	
HR 7 MPP+V	PTR5A-13	
WR 7 D+	BPR6ES	
WR 7 DC+	BPR6ES	
WR 7 LTC+	BUR6ET	
WR 7 B+	BPR6HS	
WR 7 B+	BPR6HS	Q214
WR 7 B+	BPR6HS	
WR 7 BC+	BPR6HS	
WR 7 BC+	BPR6HS	Q214
WR 7 BC+	BPR6HS	
FR 7 DC+	BKR6ES	
FR 7 DCX+	BKR6ES-11	
FR 7 LD+	BKR6EKC	
FR 7 LDC+	BKR6EKC	
FR 7 DPP 22U	PFR6N-11	
FR 7 HC 0 X	ZFR5E-11	
FR 7 DPP 10	BKR6EIX	
WR 7 DCX+	BPR6ES-11	
FGR 7 KQE 0	BKR6EQUA	
FR 7 DPP 33	PFR6Q	
FR 7 MPP 10	PLFR6A	
FGR 7 DQE+	BKR6EKUB	
FR 7 DPP+	PFR6B	
FR 7 HE 2	ZFR5P-G	
HR 7 MPP 302	PTR5A-13	
HR 7 MPP 302 X	PTR5A-13	
FR 7 SI 30	ILZFR6C-11K	



BOSCH	→ NGK	Quick
FR 7 KPP 332	IZFR6H11	
HR 7 DC+	BPR6EFS	
WR 7 DC+	BPR6ES	
WR 7 LTC+	BUR6ET	
WR 7 BC+	BPR6HS	
WR 7 BC+	BPR6HS	Q214
WR 7 BC+	BPR6HS	
FR 7 DC+	BKR6ES	
FR 7 DCX+	BKR6ES-11	
FR 7 LDC+	BKR6EKC	
WR 7 DCX+	BPR6ES-11	
HR 7 MPP+	PTR5A-13	
FGR 7 DQE+	BKR6EKUB	
FR 7 DPP+	PFR6B	
FR 7 DC+	BKR6ES	
WR 7 DC+	BPR6ES	
WR 7 LTC+	BUR6ET	
HR 7 DCX+	BPR6EFS-13	
FR 7 KC+	BKR6EY	
FGR 7 DQP+	BKR6EQUP	
FR 7 KPP 33+	PFR6Q	
FR 7 HC+	ZFR6T-11G	
FR 7 HPP 33+	PZFR5D-11	
FR 7 KCX+	BKR6EY-11	
FR 7 LCX+	ZFR6F-11	
FR 7 NPP 332	ILZFR6D11	
FR 7 NI 33	ILFR6B	
FR 7 KCX+	BKR6EY-11	
FR 7 LCX+	ZFR6F-11	
HR 7 DCY+	BPR6EFS-15	
HR 7 DCX+	BPR6EFS-13	
FR 7 KC+	BKR6EY	
FGR 7 DQP+	BKR6EQUP	
FR 7 KPP 33+	PFR6Q	
FR 7 HC+	ZFR6T-11G	
FR 7 HPP 33+	PZFR5D-11	
FR 7 NI 332S	ILFR6K8	
FR 7 KPP 332 U	PFR6X-11	
FR 7 DII 35 V	DIFR6A13G	
FR 7 SPP 302 U	LZFR6AP11GS	
FR 7 NII 352 U	DILFR6A11	
WR 6 DC	BPR6ES	
HR 6 DC	BPR6EFS	
WR 6 DS	BPR6EIX	
HR 6 DS	BPR6EFS	
HR 6 BC	BPR6FS	
WR 6 DP	BPR6ES	
HR 6 DP	BPR6EFS	
FR 6 DC	BKR6ES	
FR 6 DTC	BCPR6ET	
FR 6 DP	BKR6ES	
WR 6 DCX	BPR6ES-11	

BOSCH	→ NGK	Quick
WR 6 DPX	BPR6ES-11	
FR 6 DPX	BKR6ES-11	
FR 6 DCX	BKR6ES-11	
WR 6 DTC	BUR6ET	
FR 6 DTCW	BKR5EKC	
FR 6 LDC	BKR6EK	
WR 6 BC	BPR6HS	
WR 6 BC	BPR6HS	Q214
WR 6 BC	BPR6HS	
FR 6 KDC	BKR6EZ	
FR 6 DDC	BKR7EKC	
FR 6 LDC	BKR6EK	
HGR 6 KQC	BUR6EFSZ	
FR 6 KTC	BKUR6ET	
WR 6 DC	BPR6ES	
WSR 6 E	BMR6A	Q307
FR 6 KDE 0	BKR6EKE	
FGR 6 KQE	BKR6EQUP	
FGR 6 HQE 0	ZFR6S-Q	
HR 6 D+	BPR6EFS	
HR 6 DC+	BPR6EFS	
WR 6 D+	BPR6ES	
WR 6 DC+	BPR6ES	
FR 6 D+	BKR6ES	
FR 6 DC+	BKR6ES	
FR 6 DP	BKR6ES	
FR 6 MPP 332	ILFR6A	
FR 6 KDC+	BKR6EZ	
FR 6 HI 332	PZFR6R	
HR 6 DC+	BPR6EFS	
WR 6 DC+	BPR6ES	
FR 6 DC+	BKR6ES	
FR 6 DC+	BKR6ES	
WR 5 DS	BPR7EIX	
FR 5 LDC	BKR7EKC	
WR 5 DS	BPR7EIX	
FR 5 DC	BCPR7ES	
WR 5 AC	BR7HS	Q211
WR 5 DP	BPR7ES	
FR 5 DP	BCPR7ES	
WR 5 CC	BR7ES	
FR 5 DC	BCPR7ES	
WR 5 DC	BPR7ES	
FR 5 DTC	BCPR7ET	
FR 5 DCX	BCPR7ES-11	
WR 5 D+	BPR7ES	
WR 5 DC+	BPR7ES	
WR 5 CP	BR7ES	
FGR 5 KQE 0	BKR7EQUP	
FR 5 KPP 332 S	PFR7S8EG	
WR 5 DC+	BPR7ES	
WR 4 CC	BR8ES	Q207



BOSCH	→ NGK	Quick
WR 4 AC	BR8HS	Q212
WR 4 CP	BR8EIX	
WR 3 CTC	BR9ET	
WR 3 CC	BR9ES	Q208
WR 3 CS	BR9EIX	
WR 2 CC	BR10ES	
DR 10 BC	APR5FS	
DR 9 BC	APR5FS	
DR 8 BC	APR5FS	
DR 7 BC	APR6FS	
DR 6 BC	APR6FS	
F 7 LTCR	BKUR6ET-10	
F 7 LTCR	BKUR6ET-10	
WR 6 DC+	BPR6ES	
FR 7 DCX+	BKR6ES-11	
FR 8 DCX+	BKR5ES-11	
877 1207	R2349-10	
888 1101	R2349-11	
D 6 B	AP6FS	
D 6 BP	AP6FS	
D 7 A	A6FS	
D 7 B	AP6FS	
D 7 BP	AP6FS	
D 8 B	AP5FS	
D 8 BP	AP5FS	
D 9 B	AP5FS	
D 10 B	AP5FS	
DR 6 B	APR6FS	
DR 6 BP	APR6FS	
DR 7 B	APR6FS	
DR 7 BP	APR6FS	
DR 8 B	APR5FS	
DR 8 BP	APR5FS	
DR 9 B	APR5FS	
DR 10 B	APR5FS	
F 2 DTC	R6888A-9	
F 03 DAR	BKR6EK	
F 04 DAR	BKR6EK	
F 5 DP	BCP7ES	
F 5 DTC	BCP7ET	
F 5 KPP 332SB	PFR7S8EG	
F 6 DC 0	BCP6ES	
F 6 DP	BCP6ES	
F 6 DPOR	PFR6Q	
F 6 DPX	BCP6ES-11	
F 6 KPP 332 S	PFR6Q	
F 7 DCOR	BKR6ES	
F 7 DP	BCP6ES	
F 7 DPER	PFR6G-11	
F 7 HER 02	ZFR6T-11G	
F 7 HPP 22	PFR6Q	
F 7 HPP 222U	PZFR6J-11	

BOSCH	→ NGK	Quick
F 7 HPPRX	PZFR5D-11	
F 8 DC 0	BCP5ES	
F 8 DPER	IFR5D10	
F 9 LCR	ZFR4F-11	
FGR 6 KQC	BKR6EQUP	
FGR 7 DPP 10	BKR6EIX-11P	
FGR 7 KQC	BKR6EQUP	
FQ 5 NIPP 332 S	PLFER7A8EG	
FR 6 D 133	IFR6J11	
FR 6 DC 0	BKR6EK	
FR 6 DC 2	BKR6ES	
FR 6 DP 1 X	PFR6J-11	
FR 6 MPP 10	PLFR6A-11	
FR 7 DE	BKR6EZ	
FR 7 DP 1 X	PFR6B-11	
FR 7 DQP	BKR6EQUP	
FR 7 KDC	BKR6EZ	
FR 7 KI30	FR6EI	
FR 7 LDU	BKR6EK	
FR 8 DX	BKR5ES-11	
FR 8 LD+U	BKR5EK	
FR 8 LDC 4	BKR5EK	
FR 10 DX	BCPR4ES-11	
H 5 D	BP7EFS	
H 5 DP	BP7EFS	
H 6 B	BP6FS	
H 6 D	BP6EFS	
H 6 DP	BP6EFS	
H 7 CP	BR6EF	
H 7 D	BP6EFS	
H 7 DP	BP6EFS	
H 7 DPY	BP6EFS-13	
H 8 B	BP5FS	
H 8 BP	BP5FS	
H 8 DCX	BP5EFS-13	
H 8 DP	BP5EFS	
H 9 B	BP4FS	
H 9 D	BP5EFS	
H 9 HP	BP5EFS	
H 10 B	BP4FS	
H 10 C	BP4FS	
HR 6 B	BPR6FS	
HR 6 BP	BPR6FS	
HR 8 A	BR5FS	
HR 8 ACY	BR5FS	
HR 8 AP	BR5FS	
HR 8 APY	BR5FS	
HR 8 AY	BR5FS	
HR 8 B	BPR5FS	
HR 8 BPY	BPR5FS-15	
HR 8 BY	BPR5FS-15	
HR 8 LC0	TR5-1	

BOSCH	→ NGK	Quick
HR 8 LP0	TR5-1	
HR 9 A	BR5FS	
HR 9 AP	BR5FS	
HR 9 APY	BR5FS	
HR 9 AY	BR5FS	
HR 9 B	BPR4FS	
HR 9 BY	BPR4FS-15	
HR 9 D	BPR5EFS	
HR 10 A	BR5FS	
HR 10 AY	BR5FS	
HR 10 B	BPR4FS	
HR 10 BX	BPR4FS-11	
HR 10 BY	BPR4FS-15	
M 4 A	AB-7	
M 4 A1	AB-8	
M 4 A2	AB-7	
M 5 A	AB-7	
M 7 A	AB-6	
M 8 A	AB-6	
M 8 A0	AB-6	
M 10 A	AB-6	
M 10 A0	AB-6	
M 35 T1	AB-2	
M 45 T1	AB-6	
M 95 T1	AB-6	
M 95 T5	AB-6	
M 145 T1	AB-6	
M 145 T5	AB-6	
M 175 T1	AB-6	
M 175 T5	AB-6	
M 225 P11S	AB-7	
M 225 T1	AB-7	
M 240 T1	AB-7	
M 260 T1	AB-8	
M 280 T1	AB-8	
MA 95 T7	AP5FS	
MA 95 TR7	APR5FS	
MA 125 T7	AP5FS	
MA 125 TR7	APR5FS	
MA 145 T7	AP5FS	
MA 145 TR7	APR5FS	
MA 175 T1	A6FS	
MA 175 T7	AP6FS	
MA 200 T 7	AP6FS	
MA 225 T 1	A7FS	
U 175 T1	C6HSA	
U 260 T1	CR6HS	Q223
W 2 A	B9HS	
W 2 C	B10ES	
W 2 C0	B10ES	
W 2 D	BP9ES	
W 3 A	B8HS	Q205

BOSCH	→ NGK	Quick
W 3 A 0	B8HS	Q205
W 3 AP	B8HS	Q205
W 3 C	B9ES	Q202
W 3 C0	B9ES	Q202
W 3 CP	B9ES	Q202
W 3 D	BP8ES	
W 3 DP	BPR8EIX	
W 3 DP 2	BP8ES	
W 4 A	B8HS	Q205
W 4 A 1	B8HS	Q205
W 4 A 2	B8HS	Q205
W 4 A 5	B8HS	Q205
W 4 AP	B8HS	Q205
W 4 C	B8ES	Q201
W 4 C 1	B8ES	Q201
W 4 C 2	B7ES	
W 4 C3	B7HS	Q204
W 4 CP	BR8EIX	
W 4 CPX	B8ES	Q201
W 4 DP	BPR7EIX	
W 4 E2	B7S	
W 5 A	B7HS	Q204
W 5 AP	B7HS	Q204
W 5 B	BP7HS	
W 5 BP	BP7HS	
W 5 C	B7ES	
W 5 CCX	B7ES-11	
W 5 CP	B7ES	
W 5 CPX	B7ES-11	
W 5 D	BP7ES	Q206
W 5 D1	BP7ES	Q206
W 5 DC0	BP7ES	Q206
W 5 DCX	BP7ES-11	
W 5 DP	BP7ES	Q206
W 5 DPX	BP7ES-11	
W 5 E	B7S	
W 5 EP	B7S	
W 6 B	BP6HS	
W 6 BP	BP6HS	
W 6 D	BP6ES	
W 6 D1	BP6ES	
W 6 DP	BPR6EIX	
W 6 DPX	BPR6EIX-11	
W 6 LTCR	BUR6ET	
W 7 A	B6HS	Q203
W 7 A0	B6HS	Q203
W 7 AO0	B6HS	Q203
W 7 AP	B6HS	Q203
W 7 B	BP6HS	
W 7 BP	BP6HS	
W 7 C	B6ES	
W 7 CCX	B6ES-11	



BOSCH	→ NGK	Quick
W 7 CP	B6ES	
W 7 CPX	B6ES-11	
W 7 CX	B6ES-11	
W 7 D	BP6ESZ	
W 7 D0	BP6ES	
W 7 DP	BP6ES	
W 7 DPX	BP6ES-11	
W 7 DX	BP6ES-11	
W 7 E	B6S	Q302
W 7 EP	B6S	Q302
W 7 F	BP6S	
W 8 A	B5HS	
W 8 A0	B5HS	
W 8 AP	B5HS	
W 8 B	BP5HS	
W 8 BP	BP5HS	
W 8 C	B5ES	
W 8 C0	B5ES	
W 8 CCX	B5ES	
W 8 CP	B5ES	
W 8 D	BP5ES	
W 8 DCY	BP5ES-13	
W 8 DP	BP5ES	
W 8 DPX	BP5ES-11	
W 8 DX	BP5ES-11	
W 8 E	B6S	Q302
W 8 F	BP5S	
W 8 LPR	ZGR5A	
W 9 A	B-4H	
W 9 A0	B-4H	
W 9 AC0	B5HS	
W 9 C	B4ES	
W 9 D	BP5ES	
W 9 DP	BP5ES	
W 9 DPX	BP5ES-11	
W 9 E	B-4	
W 9 E0	B4-LM	Q301
W 9 F	BP5S	
W 9 FC	BP5S	
W 10 A	B-4H	
W 10 C	B4ES	
W 10 D	BP4ES	
W 10 E	B-4	
W 10 F	BP-4	
W 12 E	B-2	
W 45 T1	B-4H	
W 45 T3	B-4	
W 95 T1	B-4H	
W 95 T2	B4ES	
W 95 T3	B-4	
W 95 T6	BP-4	
W 95 T30	BP4ES	

BOSCH	→ NGK	Quick
W 95 TR6	BP-4	
W 125 T1	B-4H	
W 125 T2	B4ES	
W 125 T3	B-4	
W 125 T4	B-4H	
W 125 T6	BP5S	
W 125 T30	BP5ES	
W 125 TR2	BR5ES	
W 125 TR3	BR6S	
W 125 TR6	BP5S	
W 125 TR30	BPR5ES	
W 145 M1	B5HS	
W 145 M2	B5ES	
W 145 T1	B5HS	
W 145 T2	B5ES	
W 145 T3	B6S	Q302
W 145 T6	BP5S	
W 145 T11	B5HS	
W 145 T30	BP5ES	
W 145 T35	BP5HS	
W 145 TR2	BR5ES	
W 145 TR3	BR6S	
W 145 TR6	BP5S	
W 145 TR30	BPR5ES	
W 160 T2	B6ES	
W 160 T30	BP5ES	
W 175 T1	B6HS	Q203
W 175 T2	B6ES	
W 175 T3	B6S	Q302
W 175 T6	BP6S	
W 175 T7	BP6HS	
W 175 T30	BP6ES	
W 175 T35	BP6HS	
W 175 TR1	BR6HS	Q209
W 175 TR2	BR6ES	
W 175 TR30	BPR6ES	
W 175 TR35	BPR6HS	
W 175 TR35	BPR6HS	Q214
W 175 TR35	BPR6HS	
W 175 Z1	B6HS	Q203
W 190 M11S	BR6HIX	
W 200 T27	BP6ES	
W 200 T30	BP6ES	
W 200 T35	BP6HS	
W 200 TR30	BPR6ES	
W 215 P21	BPR7EIX	
W 215 T30	BP6ES	
W 220 T30	BP6ES	
W 225 S1S	BR7HIX	
W 225 S2S	BR7EIX	
W 225 T1	B7HS	Q204
W 225 T2	B7ES	



BOSCH	→ NGK	Quick
W 225 T3	B7S	
W 225 T7	BPR7HS	Q215
W 225 T30	BP8ES	
W 225 T35	BP7HS	
W 225 TR1	BR7HS	Q211
W 225 TR2	BR7ES	
W 225 TR30	BPR7ES	
W 230 T30	BP7ES	Q206
W 235 P21	BP7ES	Q206
W 235 T28	BP8ES	
W 240 M1	B8HS	Q205
W 240 MZ1	B8HS	Q205
W 240 T1	B8HS	Q205
W 240 T2	B8ES	Q201
W 240 T3	B7S	
W 240 T28	B8ES	Q201
W 250 P21	BP7ES	Q206
W 250 T1	B8HS	Q205
W 250 T2	B8ES	Q201
W 250 TR2	BR8ES	Q207
W 255 T30	BP7ES	Q206
W 260 M1	B8HS	Q205
W 260 MZ1	B8HS	Q205
W 260 MZ2	B9ES	Q202
W 260 S1S	BR8HIX	
W 260 S2S	BR8EIX	
W 260 T1	B8HS	Q205
W 260 T2	B8ES	Q201
W 260 T20	B8ES	Q201
W 260 T30	BP8ES	
W 265 P21	BPR9EIX	
W 275 T1	B8HS	Q205
W 275 T2	B9ES	Q202
W 280 MZ1	B8HS	Q205
W 280 MZ2	B9ES	Q202
W 280 P21	BP8ES	
W 280 S1S	BR9HIX	
W 280 S2S	BR9EIX	
W 280 T30	BP8ES	
W 300 MZ2	B10ES	
W 300 T1	B9HS	
W 300 T2	B10ES	
W 300 T30	BP9ES	
W 310 S1S	BR9HIX	
W 310 S2S	BR10EIX	
W 330 T1	B9HS	
W 340 S1S	BR9HIX	
W 340 S2S	BR10EIX	
W 370 S1S	BR10HIX	
W 370 S2S	BR10EIX	
W 400 S1S	BR10HIX	
W 400 S2S	BR10EIX	

BOSCH	→ NGK	Quick
WA 95 T40	BP4FS	
WA 95 TR4	BR5FS	
WA 95 TR40	BPR4FS	
WA 125 T30	BP5EFS	
WA 125 T40	BP4FS	
WA 125 TR4	BR5FS	
WA 125 TR30	BPR5EFS	
WA 125 TR40	BPR4FS	
WA 145 T40	BP5FS	
WA 145 TR4	BR5FS	
WA 145 TR40	BPR5FS	
WA 175 T30	BP6EFS	
WA 200 T30	BP6EFS	
WA 200 T40	BP6FS	
WA 200 TR30	BPR6EFS	
WA 200 TR40	BPR6FS	
WA 225 T30	BP7EFS	
WAK 145 T3	BM6F	
WAK 225 T3	BM7F	
WEC	BUE	
WET 1	BUH	
WET 2	BUE	
WG 235 T28	BP7ES	Q206
WG 250 P21	BPR9EIX	
WG 250 T28	BPR8EIX	
WG 250 T30	BP8ES	
WG 265 T2SP	BPR9EIX	
WKA 145 T3	BM6A	Q303
WKA 145 T6	BPM6A	Q304
WKA 145 TR6	BPMR6A	Q308
WKA 175 T3	BM6A	Q303
WKA 175 T6	BPM6A	Q304
WKA 200 TR6	BPMR6A	Q308
WKA 225 T3	BM7A	
WKA 225 T6	BPM7A	Q305
WR 5 A	BR7HS	Q211
WR 5 C	BR7ES	
WR 7 A	BR6HS	Q209
WR 7 C	BR6ES	
WR 7 F	BP6S	
WR 8 C	BR5ES	
WR 8 DC0	BPR5ES	
WR 8 DPY	BPR5ES-13	
WR 8 E	BR6S	
WR 8 EP	BR6S	
WR 8 F	BP5S	
WR 8 FP	BP5S	
WR 8 FPY	BP5S	
WR 8 HP	ZGR5C	
WR 9 A0	BR5HS	
WR 9 C	BR5ES	
WR 9 DY	BPR5ES-13	



BOSCH	→ NGK	Quick
WR 9 E	BR6S	
WR 9 E0	BR6S	
WR 9 F	BP5S	
WR 9 FY	BP5S	
WR 9 H	ZGR5C	
WR 9 HP	ZGR5C	
WR 9 LC	ZGR5A	
WR 10 A	BR4HS	
WR 10 E	BR6S	
WR 10 F	BP-4	
WR 10 FY	BP-4	
WSR 9 E	BMR4A	Q306
X 3 CP0	D9EA	
X 175 T1	D5HS	
X 260 T1	D6HA	
X 260 T2	D6EA	
X 300 T1	D8HA	
X 300 T2	D9EA	
XR 2 AS	DR8HS	

BRISK	→ NGK	Quick
B 12 YC	DP9EA-9	
B 14 YC	DP8EA-9	
B 15 YC	DP7EA-9	
D 12 YC	BCP7ES	
D 14 Y	BCP7ES	
D 14 YC	BCP7ES	
D 15 Y	BCP6ES	
D 15 YC	BCP6ES	
D 17 Y	BCP5ES	
D 17 YC	BCP5ES	
DOX 15 LE 1	ZFR6T-11G	
DR 12 YC	BKR7E	
DR 14 YC	BKR7E	
DR 14 ZC	ZFR7F-11	
DR 14 ZC 1	BCPR7ES-11	
DR 15 TC	BKUR5ET-10	
DR 15 YC	BKR6ES	
DR 15 Z	BKR6ES	
DR 15 Z 1	BKR6ES-11	
DR 17 YC	BKR5ES	
F 14 YC	AP7FS	
F 15 YC	AP6FS	
FR 14 YC	APR6FS	
FR 15 YC	APR6FS	
G 12 YC	BP7EFS	
G 14 Y	BP7EFS	
G 14 YC	BP7EFS	
G 15 Y	BP6EFS	
G 15 YC	BP6EFS	
G 17 Y	BP5EFS	

BRISK	→ NGK	Quick
G 17 YC	BP5EFS	
GR 15 YC	BPR6EFS	
GR 17 YC	BPR5EFS	
J 17	B4-LM	Q301
J 19	B2-LM	
JR 17	BR4-LM	
JR 19	BR2-LM	Q310
K 15 YC	BP6S	
K 17 C	B6S	Q302
K 17 Y	BP5S	
K 19	B-4	
L 08 JW	BR10EIX	
L 08 W	BR10EIX	
L 10 JW	BR8EIX	
L 12 W	BR9EIX	
L 12 Y	BP8ES	
L 12 YC	BP8ES	
L 14	B8ES	Q201
L 14 C	B8ES	Q201
L 14 Y	BP7ES	Q206
L 14 YC	BP7ES	Q206
L 15	B7ES	
L 15 C	B7ES	
L 15 W	BR7EIX	
L 15 Y	BP6ES	
L 15 YC	BP6ES	
L 17	B6ES	
L 17 C	B6ES	
L 17 W	BR7EIX	
L 17 Y	BP5ES	
L 17 YC	BP5ES	
L 19 C	B5ES	
LR 12 YC	BPR8ES	Q213
LR 12 ZC	BPR8ES	Q213
LR 14 TXS	BUR6ET	
LR 14 YC	BPR7ES	
LR 14 ZC	BPR7ES	
LR 14 ZC 1	BPR7ES-11	
LR 15 TXS	BUR6ET	
LR 15 YC	BPR6ES	
LR 15 Z	BPR6ES	
LR 15 Z 1	BPR6ES-11	
LR 17 YC	BPR5ES	
N 08 W	BR10HIX	
N 12 W	BR9HIX	
N 12 Y	BP8HS	
N 12 YC	BP8HS	
N 14	B8HS	Q205
N 14 C	B8HS	Q205
N 14 Y	BP7HS	
N 14 YC	BP7HS	
N 15	B7HS	Q204



BRISK	→ NGK	Quick
N 15 C	B7HS	Q204
N 15 W	BR8HIX	
N 15 Y	BP6HS	
N 15 YC	BP6HS	
N 17	B6HS	Q203
N 17 C	B6HS	Q203
N 17 W	BR7HIX	
N 17 Y	BP5HS	
N 17 YC	BP5HS	
N 19	B5HS	
N 19 C	B5HS	
NR 12 YC	BPR8HS	
NR 15 YC	BPR6HS	
NR 15 YC	BPR6HS	Q214
NR 15 YC	BPR6HS	
P 15	BM7A	
P 15 Y	BPM7A	Q305
P 17	BM6A	Q303
P 17 Y	BPM6A	Q304
PR 17 Y	BPMR6A	Q308
U 15	BM7F	
U 17	BM6F	
UR 17	BMR6F	
CHAMPION	→ NGK	Quick
860	A6FS	
2301	BPR5ES-11	
2322	BPR4ES-11	
2332	BPR6ES	
2338	BKR6ES	
2415	BPR5ES	
2430	BKR5E-11	
3322	BPR5EIX-11	
3344	BKR6EIX-11	
3407	TR5-1IX	
5828	BZ7HS-10	
5843	BM7A	
5846	BM6A	Q303
5847	BM6F	
5861	B2-LM	
88 091	DPR7EA-9	Q220
9179 100	PFR6G	
9202 064	BKR6EKUB	
9407	ILZKR7B11GS	
A 53 C	R2349-11	
A 53 R	R2349-11	
A 55 C	R2525-10	
A 59 C	D9EA	
C 55 R	R7436-10	
C 55	R7436-10	
C 57 A	R7436-10	

CHAMPION	→ NGK	Quick
C 61	R7436-8	
D 6	AB-8	
D 9	AB-6	
D 14	AB-6	
D 16 J	AB-6	
D 16	AB-6	
D 21	AB-6	
D 23	AB-6	
EON 1	BKR6ES	
EON 2	BKR5ES	
EON 3	BPR5EFS	
EON 4	TR5A-10	
EON 5	BPR6ES	
EON 6	BPR5ES	
F 9 YC	AP6FS	
G 54 V	R0045Q-10	
H 8 C	B-6L	
J 8 C	B6S	Q302
J 12 YC	BP5S	
L 78 C	B7HS	Q204
L 82 C	B6HS	Q203
L 90 C	B5HS	
N 21	B4ES	
N 279 YC	BP7ES	Q206
N 9 YC	BP6ES	
N 9 YC	BP6ES	
RC 9 YCC	BKR6ES	
RC 9 YCC	BKR6ES	
RC 9 YCC	BKR6ES	
C 9 YC	BCP6ES	
RN 9 YCC	BPR6ES	
RN 9 YCC	BPR6ES	
RN 9 YCC	BPR6ES	
RC 9 YC	BKR6ES	
RC 9 YC	BKR6ES	
RN 9 YC	BPR6ES	
RN 9 YC	BPR6ES	
RN 9 YC	BPR6ES	
L 87 YC	BP6HS	
RN 7 YCC	BPR7ES	
RN 7 YCC	BPR7ES	
RN 7 YCC	BPR7ES	
S 9 YC	BP6EFS	
S 9 YC	BP6EFS	
S 9 YC	BP6EFS	
N 7 YC	BP7ES	Q206
N 7 YC	BP7ES	Q206
RS 9 YC	BPR6EFS	
RS 9 YC	BPR6EFS	
RS 9 YC	BPR6EFS	
N 7 BYC	BUR6ET	
N 7 BYC	BUR6ET	

CHAMPION	→ NGK	Quick
RC 12 YC	BKR5ES	
RC 7 YCC	BCPR7ES	
RC 7 YCC	BCPR7ES	
RC 7 YCC	BCPR7ES	
N 12 YC	BP5ES	
RC 10 YCC	BKR6ES	
RC 10 YCC	BKR6ES	
C 7 YC	BCP7ES	
RN 7 YC	BPR7ES	
RN 7 YC	BPR7ES	
RN 7 YC	BPR7ES	
RC 10 DMC	BKR5EK	
RC 10 DMC	BKR5EK	
RC 10 DMC	BKR5EK	
RS 9 YCC	BPR6EFS	
RS 9 YCC	BPR6EFS	
RC 7 BMC	BCPR6ET	
RC 7 BMC	BCPR6ET	
N 9 YCC	BP6ES	
C 9 YCC	BCP6ES	
C 9 YCC	BCP6ES	
RC 9 YCC4	BKR6E-11	
RN 8 VTYC4	BUR6ET	
RN 8 VTYC4	BUR6ET	
RC 8 DMC	BKR6EK	
RC 8 DMC	BKR6EK	
RN 10 VTYC4	BUR5ET-10	
RN 10 VTYC4	BUR5ET-10	
N 9 BYC4	BP5ET-10	
N 9 BYC4	BP5ET-10	
RC 8 BYC	BKR6EKC	
RES 9 YCC4	PTR5A-13	
RES 9 YCC4	PTR5A-13	
RC 8 VTYC4	BKUR6ET-10	
RC 8 VTYC4	BKUR6ET-10	
RC 87 YCL	BKR6EZ	
RC 8 YCL	BKR6ES	
REC 9 YCL	LFR5B	
REC 9 YCL	LFR5B	
S 9 YCC	BP6EFS	
S 9 YCC	BP6EFS	
S 9 YCC	BP6EFS	
L 86 C	B6HS	Q203
L 82 YC	BP6HS	
RC 9 YC4	BKR6ES-11	
N 2 C	B9ES	Q202
RC 12 LYC	ZFR5F	
RN 12 YC	BPR5ES	
RC 7 YC	BCPR7ES	
RC 7 YC	BCPR7ES	
RC 7 YC	BCPR7ES	
N 9 BYC	BUR6ET	

CHAMPION	→ NGK	Quick
RN 11 YCC	BPR5ES	
RN 11 YCC	BPR5ES	
N 7 YCC	BP7ES	Q206
RN 9 YC4	BPR6ES-11	
RN 9 YC4	BPR6ES-11	
RN 11 YC4	BPR5ES-11	
RN 11 YC4	BPR5ES-11	
S 7 YC	BP7EFS	
S 7 YC	BP7EFS	
S 7 YC	BP7EFS	
RN 11 YC	BPR5ES	
RA 4 HCX	DCPR9EIX	
RF 7 YCC	APR6FS	
RF 7 YC	APR6FS	
N 12 YCC	BP5ES	
RC 7 YCC4	BKR7ES-11	
RC 7 YCC4	BKR7ES-11	
RC 7 YCC4	BKR7ES-11	
C 11 YCC	BCP5ES	
C 7 YCC	BCP7ES	
L 92 YC	BP5HS	
RN 9 LCC	ZGR5B	
RN 9 LCC	ZGR5B	
F 7 YC	AP7FS	
RC 10 YC4	BKR6ES-11	
RL 82 YC	BPR6HS	
RL 82 YC	BPR6HS	Q214
RL 82 YC	BPR6HS	
RL 82 YC	BPR6HS	
RL 82 YC	BPR6HS	Q214
RL 82 YC	BPR6HS	
N 11 YC	BP5ES	
S 7 YCC	BP7EFS	
S 7 YCC	BP7EFS	
N 3 C	B8ES	Q201
L 87 YCC	BP6HS	
RL 82 YCC	BPR6HS	
RL 82 YCC	BPR6HS	Q214
RL 82 YCC	BPR6HS	
N 5 C	B6ES	
C 6 YCC	BCP7ES	
C 6 BYC	BCP7ET	
RC 7 BYC4	BCPR6ET	
N 3 G	BR8EIX	
N 4 C	B7ES	
RC 7 YC4	BKR7ES-11	
N 6 YCC	BP8ES	
N 6 YCC	BP8ES	
RC 9 BMC	BKR5EKU	
RL 82 C	BR6HS	Q209
N 6 YC	BP8ES	
N 6 YC	BP8ES	



CHAMPION	→ NGK	Quick
RC 10 YC	BKR5E	
RC 9 MCC4	ZFR6F-11	
S 6 YC	BP7EFS	
S 6 YC	BP7EFS	
RN 2 C	BR9ES	Q208
RG 4 HC	CR9E	Q227
RC 89 YCC	BKR5EZ	
RC 6 YCC	BCPR7ES	
N 7 BMC	BUR6ET	
N 7 BMC	BUR6ET	
L 86 CC	B6HS	Q203
RN 4 C	BR7ES	
N 9 BMC	BPR5EKU	
RC 87 YCC	BKR6EZ	
A 59 GC	DCPR9EIX	
L 82 YCC	BP6HS	
RN 14 PMP5	GR4	
N 11 YCC	BP5ES	
RN 7 YCC4	BPR7ES-11	
RN 3 C	BR8ES	Q207
N 6 BYC	BUR6ET	
RC 6 YC	BCPR7ES	
RN 10 YC	BPR6ES	
A 6 GC	DR8EIX	
RC 11 LCC4	BRE527Y-11	
RC 12 ECC	ZFR5N	
RN 6 YC	BPR8ES	Q213
RC 8 YCC	BKR6ES	
RC 89 TMC	BKUR5ET-10	
RG 4 PHP	PMR7A	
RC 10 PYP4	PFR5J-11	
N 2 G	BR9EIX	
RC 8 YC	BKR5E	
C 6 VPYC	BKR7EIX-11	
REA 8 MX	LZKAR7B	
REA 8 MX	LZKAR7B	
A 6 HC	DP8EA-9	
RC 12 PYP	PFR5J-11	
RC 8 PYP	PFR6J-11	
RC 11 PYPB4	PFR5G-11	
RC 10 PYC	BKR6EIX	
RC 8 PYCB	PFR6G-9	
RC 87 PYC	BKUR6ET-10	
RC 87 PYC	BKUR6ET-10	
RC 8 PYPB4	PFR5G-13E	
RS 12 YC	BPR5EFS	
RS 12 YC	BPR5EFS	
RC 8 YC4	BKR5E-11	
RC 12 MCC4	ZFR5F-11	
RF 9 YC	APR6FS	
RN 13 LYC	ZGR5C	
RFN 14 LY	ZFR4F-11	

CHAMPION	→ NGK	Quick
RN 5 C	BR6ES	
C 57 YCST	R7436-9	
G 59 C	C7E	
RE 14 PLP5	PLZTR5A-13	
RS 12 PYP	TR5IX	
S 59 CST	R5724-9	
RV 9 YC	BPR6FS	
N 84	B9EG	
A 57 CST	R2525-10	
RE 10 PMC5	PTR5A-13	
REC 10 PYC4	LFR5AP-11	
REC 9 MCLX	LFR5B	
REC 9 MCLX	LFR5B	
REC 10 WYPB4	IFR5G11	
REC 10 WYPB4	IFR5G11	
RER 8 YC	PLKR7A	
RC 10 MCC	ZFR6V-G	
RA 7 YC	DCPR8E	
RER 8 MC	LZKR6B-10E	
OE 001	BP6ES	
OE 001	BP6ES	
OE 002	BKR6ES	
OE 002	BKR6ES	
OE 002	BKR6ES	
OE 003	BCP6ES	
OE 004	BPR6ES	
OE 004	BPR6ES	
OE 004	BPR6ES	
OE 005	BKR6ES	
OE 005	BKR6ES	
OE 006	BPR6ES	
OE 006	BPR6ES	
OE 006	BPR6ES	
OE 007	BP6HS	
OE 008	BPR7ES	
OE 008	BPR7ES	
OE 008	BPR7ES	
OE 009	BP6EFS	
OE 009	BP6EFS	
OE 009	BP6EFS	
OE 010	BP7ES	Q206
OE 010	BP7ES	Q206
OE 011	BPR6EFS	
OE 011	BPR6EFS	
OE 011	BPR6EFS	
OE 012	BUR6ET	
OE 012	BUR6ET	
OE 013	BKR5ES	
OE 014	BCPR7ES	
OE 014	BCPR7ES	
OE 014	BCPR7ES	
OE 015	BP5ES	

CHAMPION	→ NGK	Quick
OE 016	BKR6ES	
OE 016	BKR6ES	
OE 017	BCP7ES	
OE 018	BPR7ES	
OE 018	BPR7ES	
OE 018	BPR7ES	
OE 018	BPR7ES	
OE 019	BKR5EK	
OE 019	BKR5EK	
OE 019	BKR5EK	
OE 020	BPR6EFS	
OE 020	BPR6EFS	
OE 021	BCPR6ET	
OE 021	BCPR6ET	
OE 022	BP6ES	
OE 023	BCP6ES	
OE 023	BCP6ES	
OE 024	BKR6E-11	
OE 025	BUR6ET	
OE 025	BUR6ET	
OE 026	BKR6EK	
OE 026	BKR6EK	
OE 027	BUR5ET-10	
OE 027	BUR5ET-10	
OE 028	BP5ET-10	
OE 028	BP5ET-10	
OE 030	BKR6EKC	
OE 031	PTR5A-13	
OE 031	PTR5A-13	
OE 032	BKUR6ET-10	
OE 032	BKUR6ET-10	
OE 033	BKR6EZ	
OE 034	BKR6ES	
OE 035	LFR5B	
OE 035	LFR5B	
OE 036	BP6EFS	
OE 036	BP6EFS	
OE 036	BP6EFS	
OE 037	B6HS	Q203
OE 038	BP6HS	
OE 039	BKR6ES-11	
OE 040	B9ES	Q202
OE 041	ZFR5F	
OE 042	BPR5ES	
OE 043	BCPR7ES	
OE 043	BCPR7ES	
OE 043	BCPR7ES	
OE 044	BUR6ET	
OE 045	BPR5ES	
OE 045	BPR5ES	
OE 046	BP7ES	Q206
OE 048	BPR6ES-11	
OE 048	BPR6ES-11	

CHAMPION	→ NGK	Quick
OE 049	BPR5ES-11	
OE 049	BPR5ES-11	
OE 050	BP7EFS	
OE 050	BP7EFS	
OE 050	BP7EFS	
OE 051	BPR5ES	
OE 052	DCPR9EIX	
OE 053	APR6FS	
OE 054	APR6FS	
OE 055	BP5ES	
OE 056	BKR7ES-11	
OE 056	BKR7ES-11	
OE 056	BKR7ES-11	
OE 057	BCP5ES	
OE 058	BCP7ES	
OE 059	BP5HS	
OE 060	ZGR5B	
OE 060	ZGR5B	
OE 061	AP7FS	
OE 063	BKR6ES-11	
OE 064	BPR6HS	
OE 064	BPR6HS	Q214
OE 064	BPR6HS	
OE 064	BPR6HS	
OE 064	BPR6HS	Q214
OE 064	BPR6HS	
OE 065	BP5ES	
OE 067	BP7EFS	
OE 067	BP7EFS	
OE 068	B8ES	Q201
OE 070	BP6HS	
OE 071	BPR6HS	
OE 071	BPR6HS	Q214
OE 071	BPR6HS	
OE 074	B6ES	
OE 075	BCP7ES	
OE 076	BCP7ET	
OE 077	BCPR6ET	
OE 078	BR8EIX	
OE 079	B7ES	
OE 080	BKR7ES-11	
OE 084	BP8ES	
OE 084	BP8ES	
OE 085	BKR5EKU	
OE 086	BR6HS	Q209
OE 087	BP8ES	
OE 087	BP8ES	
OE 088	BKR5E	
OE 089	ZFR6F-11	
OE 090	BP7EFS	
OE 090	BP7EFS	
OE 091	BR9ES	Q208



CHAMPION	→ NGK	Quick
OE 092	CR9E	Q227
OE 093	BKR5EZ	
OE 094	BCPR7ES	
OE 095	BUR6ET	
OE 095	BUR6ET	
OE 096	B6HS	Q203
OE 098	BR7ES	
OE 100	BPR5EKU	
OE 102	BKR6EZ	
OE 103	DCPR9EIX	
OE 104	BP6HS	
OE 105	GR4	
OE 106	BP5ES	
OE 107	BPR7ES-11	
OE 108	BR8ES	Q207
OE 109	BUR6ET	
OE 110	BCPR7ES	
OE 111	BPR6ES	
OE 112	DR8EIX	
OE 114	BRE527Y-11	
OE 115	ZFR5N	
OE 116	BPR8ES	Q213
OE 119	BKR6ES	
OE 120	BKUR5ET-10	
OE 122	PMR7A	
OE 124	PFR5J-11	
OE 125	BR9EIX	
OE 127	BKR5E	
OE 129	BKR7EIX-11	
OE 130	LZKAR7B	
OE 130	LZKAR7B	
OE 132	DP8EA-9	
OE 134	PFR5J-11	
OE 136	PFR6J-11	
OE 138	PFR5G-11	
OE 141	BKR6EIX	
OE 143	PFR6G-9	
OE 144	BKUR6ET-10	
OE 144	BKUR6ET-10	
OE 146	PFR5G-13E	
OE 151	BPR5EFS	
OE 151	BPR5EFS	
OE 152	BKR5E-11	
OE 154	ZFR5F-11	
OE 155	APR6FS	
OE 156	ZGR5C	
OE 160	ZFR4F-11	
OE 161	GR4	
OE 162	BR6ES	
OE 163	LZTR4A-11	
OE 165	R7436-9	
OE 166	C7E	

CHAMPION	→ NGK	Quick
OE 167	PLZTR5A-13	
OE 168	TR5IX	
OE 169	R5724-9	
OE 171	BPR6FS	
OE 172	B9EG	
OE 173	R2525-10	
OE 174	PTR5A-13	
OE 175	LFR5AP-11	
OE 178	LFR5B	
OE 178	LFR5B	
OE 190	IFR5G11	
OE 190	IFR5G11	
OE 197	PLKR7A	
OE 198	ZFR6V-G	
OE 199	DCPR8E	
OE 201	LZKR6B-10E	
RERX 4 ZWYPB	SILZKGR8B8S	
P-RG 6 HCC	CPR8EA-9	
QC 10 WEP	IZFR6F11	
9005	IZFR6F11	
QC 12 PEP	PZFR6H	
QC 12 YC	BKR5ES	
QN 84	BR9EG	
RA 8 HC	DCPR7E	
RA 59 GC	DCPR9EIX	
RC 7 YC3	BKR7E	
RC 12 MC4	PZFR5F-11	
RC 12 PEC5	ZFR5LP-13G	
RC 12 YC5	FR45	
RC 14 YC	BKR5ES	
RE 14 MCC4	LZTR4A-11	
RE 14 MCC5	LZTR4A-11	
RF 10 C	AR6FS	
RF 11 YC	APR6FS	
RG 6 YC	CR8EB	
RH 10 C	B-6L	
RH 18 Y	B-4L	
RJ 6 C	BR6S	
RJ 8 C	BR6S	
RJ 14 YC	BP5S	
RJ 18 YC	BP-4	
RJ 18 YC6	XR45IX	
RL 78 C	BR7HS	Q211
RL 86 C	BR6HS	Q209
RL 95 YC	BPR5HS	
RN 14 MC5	BPR4EY-11	
RN 14 YC	GR4	
RN 16 YC5	BPR4ES-13	
RS 5 C	BR7EFS	
RS 10 LC	TR5-1	
RS 14 LC	TR5-1	
RS 14 YC	BPR5EFS	



CHAMPION	→ NGK	Quick
RS 14 YC6	TR55IX	
RS 15 LYC	TR4	
RS 17 YX	TR4	
RV 12 C	BR5FS	
RV 12 YC	BPR5FS	
RV 15 YC4	BPR4FS-11	
RV 15 YC6	BPR4FS-15	
RV 17 YC	BPR4FS	
RV 17 YC6	BPR4FS-15	
UD 16	AB-6	
V 63 C	R5673-7	
A 4 HC	DP9EA-9	
A 5 YC	DP9EA-9	
A 6	D8EA	Q216
A 6 G	DR8EIX	
A 6 Y	DP8EA-9	
A 6 YC	DP8EA-9	
A 8	D7EA	
A 8 Y	DP7EA-9	
A 8 YC	DP7EA-9	
A 10	D7EA	
A 50 R	R2349-11	
A 51 R	R2525-10	
A 55 R	R2525-10	
A 55 V	R2349-11	
A 57 G	R2525-10	
A 59 G	DR9EIX	
A 61	D9EA	
A 61 G	DR9EIX	
BL 4	B7FS	
BL 5	B7FS	
BL 6	BR6FS	
BL 7 Y	BP7FS	
BL 8	BR6FS	
BL 9 Y	BP6FS	
BL 11 Y	BP5FS	
BL 13 Y	BP5FS	
BN 2	B9EFS	
BN 6 Y	BP7EFS	
BN 7 Y	BP6EFS	
BN 9 Y	BP6EFS	
BN 12 Y	BP5EFS	
BN 89 Y	BP6EFS	
C 7 Y	BCP7ES	
C 7 YCX	BCP7ES	
C 9 MCC	ZFR5F	
C 9 Y	BCP6ES	
C 9 YCX	BCP6ES	
C 10 YCC	BCP6ES	
C 12 YCC	BK5E	
C 57	R7436-9	
C 57 C	R7436-9	

CHAMPION	→ NGK	Quick
C 57 CX	R7434-10	
C 57 JC4	R7436-10	
C 59	R7436-9	
C 59 C	R7436-9	
C 281 YC	BCP6ES	
CJ 3	BM7A	
CJ 4	BM7A	
CJ 6	BM7A	
CJ 6 Y	BPM7A	Q305
CJ 7 Y	BPM7A	Q305
CJ 8	BM6A	Q303
CJ 8 Y	BPM6A	Q304
CJ 11	BM6A	Q303
CJ 14	BM4A	
CJ 17 LM	B4-LM	Q301
CJ 86	BM6A	Q303
D 9 J	AB-6	
D 10	AB-6	
DJ 6 J	BM7F	
DJ 6 Y	BPM7F	
DJ 7 J	BM6F	
DJ 7 Y	BPM6F	
DJ 8 J	BM6F	
F 7 Y	AP7FS	
F 7 YCC	AP7FS	
F 9 Y	AP6FS	
F 10	A6FS	
F 10 C	A6FS	
F 11 Y	AP5FS	
F 11 YC	AP5FS	
F 14 Y	AP5FS	
F 62 Y	AP8FS	
F 81 Y	AP8FS	
F 82	A8FS	
F 83 Y	AP8FS	
FN 507 Y	BCP7ES	
G 1	C9E	
G 2	C8E	
G 55	C9E	
G 56 R	R0373A-10	
G 58	C9E	
G 61	C8E	
G 63	C8E	
G 63 R	CR8EIX	
H 03	B6S	Q302
H 8	B-6L	
H 8 J	B-6L	
H 10	B-6L	
H 10 C	B-6L	
H 10 J	B-6L	
H 11	B-4L	
H 12	B-4L	



CHAMPION	→ NGK	Quick
J 4	B7S	
J 4 C	B7S	
J 4 J	B7S	
J 5	B7S	
J 6	B6S	Q302
J 6 C	B6S	Q302
J 6 J	B6S	Q302
J 7	B6S	Q302
J 7 J	B6S	Q302
J 8	B6S	Q302
J 8 J	B6S	Q302
J 10 Y	BP6S	
J 11	B-4	
J 11 C	B-4	
J 11 J	B-4	
J 11 Y	BP5S	
J 12 J	B-2	
J 12 Y	BP5S	
J 13 Y	BP5S	
J 14	B-2	
J 14 J	B-2	
J 14 Y	BP5S	
J 14 YC	BP5S	
J 17 LM	B4-LM	Q301
J 18 Y	BP-4	
J 18 YC	BP-4	
J 19 LM	B2-LM	
K 3 G	AB-8	
K 5 G	AB-8	
K 7	AB-8	
K 8	AB-8	
K 8 G	AB-8	
K 9	AB-7	
K 13	AB-6	
K 15 J	AB-6	
L 2 G	BR9HIX	
L 3 G	BR8HIX	
L 4 G	BR7HIX	
L 4 J	B7HS	Q204
L 5	B7HS	Q204
L 6 G	BR7HIX	
L 6 VC	BU8H	
L 7 J	B6HS	Q203
L 9 G	BR6HIX	
L 9 J	B6HS	Q203
L 10	B6HS	Q203
L 12 Y	BP5HS	
L 14	B-4H	
L 15 Y	BP4HS	
L 19 V	BUH	
L 20 V	BUH	
L 55 G	BR10HIX	

CHAMPION	→ NGK	Quick
L 61 Y	BP8HS	
L 64 Y	BP7HS	
L 66 Y	BP6HS	
L 76 V	BUHW	
L 77 J	B7HS	Q204
L 77 J4	B7HS-10	
L 77 JC	B7HS	Q204
L 77 JC4	B7HS-10	
L 77 V	BUHW	
L 78	B7HS	Q204
L 78 V	BUHW-2	
L 78 YC	BP7HS-10	
L 78 YC6	BP8HS-15	
L 81	B7HS	Q204
L 81 Y	BP7HS	
L 82	B6HS	Q203
L 82 Y	BP6HS	
L 85	B6HS	Q203
L 85 Y	BP6HS	
L 86	B6HS	Q203
5933	B6HS	Q203
L 86 CC	B6HS	Q203
L 87 Y	BP6HS	
L 90	B5HS	
L 92 Y	BP5HS	
L 92 YC4	BP5HS-10	
L 95 Y	BP4HS	
L 288	B5HS	
N 1	B10ES	
N 1 C	B10ES	
N 2	B9ES	Q202
N 3	B8ES	Q201
N 4	B7ES	
N 4 G	BR7EIX	
N 4 YC	BP9ES	
N 5	B6ES	
N 6	B6ES	
N 6 GY	BPR8EIX	
N 6 Y	BP8ES	
N 7	B7ES	
N 7 GY	BPR7EIX	
N 7 Y	BP7ES	Q206
N 7 YCX	BP7ES	Q206
N 8	B6ES	
N 8 GY	BPR6EIX	
N 8 L	ZGR5C	
N 8 Y	BP6ES	
N 9 Y	BP6ES	
N 9 YC4	BP6ES-11	
N 9 YCE	BP5ES	
N 9 YCX	BP6ES	
N 10 PY	BPR6EIX	



CHAMPION	→ NGK	Quick
N 10 Y	BP6ES	
N 10 Y4	BP6ES-11	
N 10 YC	BP5ES	
N 11 Y	BP5ES	
N 11 YC4	BP5ES-11	
N 12 Y	BP5ES	
N 13 L	ZGR5C	
N 13 Y	BP5ES	
N 14 LY	ZGR5C	
N 14 Y	BP5ES	
N 16 Y	BP4ES	
N 16 YC	BP4ES	
N 19 V	BUE	
N 54 R	B10EG	
N 55 G	BR10EIX	
N 57	B10ES	
N 57 G	BR10EIX	
N 57 R	B10EG	
N 59 G	BR10EIX	
N 60	B9ES	Q202
N 60 R	B8EG	
N 62 R	B8EG	
N 63 Y	BP9ES	
N 64 Y	BP8ES	
N 65 Y	BP7ES	Q206
N 66 Y	BP6ES	
N 74 C	BUR6EB-11	
N 79 Y	BP6ES	
N 80	B10EG	
N 80 G	BR10EIX	
N 82	B10EG	
N 82 G	BR10EIX	
N 84 G	BR10EIX	
N 86	B9EG	
N 86 G	BR9EIX	
N 87	B8EG	
N 87 G	BR8EIX	
N 89 GY	BP6ES	
N 89 Y	BP5ES	
N 92 Y	BP4ES	
N 178 B	BR8EM	
N 180 B	B7EM	
N 281 YC	BP6ES	
N 288	B5ES	
OBL 9 Y	BPR6FS	
OJ 11 Y	BP6S	
OJ 12 Y	BP5S	
OJ 13 Y	BP5S	
ON 3	BR8ES	Q207
ON 11 Y	BP5ES	
ON 12 Y	BP5ES	
P 7	D8HA	

CHAMPION	→ NGK	Quick
P 7 G	DR8HS	
P 7 Y	D8HA	
P 8 Y	D6HA	
P 10 Y	D6HA	
PA 5 HC	D7EA	
PA 7 HC	D7EA	
PG 2 PHP	PMR8A	
PG 4 PHP	PMR7A	
PG 7 C	C7E	
PL 7 YC4	BP6HS-10	
PL 9 YC	BP6HS	
PN 5 C	B8ES	Q201
PRL 5 SC	BR6HSA	Q210
PRL 9 SC	BR4HSA	
PRZ 9 HC	CR7HSA	
PZ 7 HC	C7HSA	
PZ 9 HC	C6HSA	
Q 504 V	R2349-10	
QC 9 MC4	ZFR6F-11	
QC 10 PEPB	IZFR6N-E	
QC 12 PEPB	IZFR6N-E	
QC 501 V	R7434-10	
QJ 17 LM	BR4-LM	
QJ 19 LM	BR2-LM	Q310
QL 6 VC	BU8H	
QL 7 J5	BR6HS	Q209
QL 16 V	BUZ8H	
QL 76 V	BUZHW	
QL 77 CC	BR8HS	Q212
QL 77 J4	BZ7HS-10	
QL 77 JC4	BZ7HS-10	
QL 78 C	BR7HS	Q211
QL 78 C	BR7HS	Q211
QL 78 V	BUZHW-2	
QL 78 YC	BPR7HS	Q215
QL 78 YC	BPR7HS	Q215
QL 82 C	BR6HS	Q209
QL 82 YC	BPR6HS	
QL 82 YC	BPR6HS	Q214
QL 82 YC	BPR6HS	
QL 86	BR6HS	Q209
QL 86 C	BR6HS	Q209
QL 87 YC	BPR6HS	
QL 87 YC	BPR6HS	Q214
QL 87 YC	BPR6HS	
QL 92 LCC	BP8HS-10	
QN 2	BR9ES	Q208
QN 2 C	BR9ES	Q208
QN 2 G	BR9EIX	
QN 3	BR8ES	Q207
QN 3 C	BR8ES	Q207
QN 86	BR8EG	



CHAMPION	→ NGK	Quick
R 6	D8EA	Q216
R 6 G	DR8EIX	
R 6 J	D8EA	Q216
R 8	D7EA	
R 10	D6EA	
R 54 G	R2525-10	
RA 2 HC	DPR7EA-9	Q220
RA 4 HCC	DCPR8E	
RA 6	DR8ES-L	Q218
RA 6 Y	DPR7EA-9	Q220
RA 6 YC	DPR7EA-9	Q220
RA 8 GHC	DCPR6E	
RA 8 Y	DPR7EA-9	Q220
RA 8 YC	DPR7EA-9	Q220
RA 59 PP	DCPR9EIX	
RAX 92 C	DR9EA	Q219
RAX 92 DC	JR9C	
RAX 92 YC	DPR7EA-9	Q220
RAX 94 C	DR8EA	
RAX 94 YC	DPR7EA-9	Q220
RAX 96 C	DR7EA	
RAX 96 YC	DPR7EA-9	Q220
RBL 8	BR6FS	
RBL 9 Y	BPR6FS	
RBL 11 Y	BPR5FS	
RBL 11 Y6	BPR5FS-15	
RBL 12	BR5FS	
RBL 13 Y	BPR5FS	
RBL 13 Y6	BPR5FS-15	
RBL 15 Y	BPR4FS	
RBL 15 Y4	BPR4FS-11	
RBL 15 Y6	BPR4FS-15	
RBL 16 Y	BPR4FS	
RBL 17 Y	BPR4FS	
RBL 17 Y6	BPR4FS-15	
RBL 86	BR6FS	
RBL 126	BR5FS	
RBN 9 Y	BPR6EFS	
RBN 12 Y	BPR5EFS	
RBN 13 Y	BPR5EFS	
RBN 14 Y	BPR5EFS	
RC 6 VPYC	BKR7EIX-11	
RC 7 GYC	BKR7EIX-11	
RC 7 GYG	BKR6EIX	
RC 7 Y	BCPR7ES	
RC 8 PYP4	PFR6G-11	
RC 9 MC4	ZFR5F-11	
RC 9 TMC	BKR6EKUB	
RC 9 YC5	BKR6E-11	
RC 9 YCN4	BKR6E-11	
RC 10 ECC	ZFR6F-11	
RC 10 PYPB4	PFR5G-11	

CHAMPION	→ NGK	Quick
RC 10 YCL	BKR5EZ	
RC 12 MC5	ZFR5F-11	
RC 14 ES	ZFR5LP-13G	
RC 14 YC4	BKR5E-11	
RC 87 YC	BKR6ES	
RC 503 C	R7433-8	
RCJ 4	BMR7A	
RCJ 6	BMR7A	
RCJ 8	BMR6A	Q307
RCJ 8 Y	BPMR6A	Q308
RCJ 501 H	BPMR4A	
RD 9	AB-6	
RD 14	AB-6	
RD 16	AB-6	
RD 16 J	AB-6	
RDJ 6 J	BM7F	
RDJ 7 J	BMR6F	
RDJ 7 Y	BPMR6F	
RDJ 8 J	BMR6F	
RE 7 PYC5	PTR5A-13	
RE 7 YCC	PTR5A-13	
RE 10 LC	TR5-1IX	
RE 10 YC4	BKR5ES-11	
REA 8 MCL	LZKAR7B	
REA 12 WMB4	LZKAR6AP-11	
RF 9 Y	APR6FS	
RF 9 Y5	APR6FS	
RF 10	AR6FS	
RF 11 Y	APR6FS	
RF 14 Y	APR5FS	
RG 2 PHP	CR8EIX	
RG 6 HCC	CPR8EA-9	
RG 6 YCA	CPR8E	
RG 6 YCH	CPR8E	
RG 92 C	CR9E	Q227
RG 92 DC	CR9EK	Q230
RG 94 C	CR8E	Q226
RGU 92 C	CR9EH-9	Q229
RGU 94 C	CR8EH-9	Q228
RJ 6	BR6S	
RJ 6 J	BR6S	
RJ 7	BR6S	
RJ 8	BR6S	
RJ 8 J	BR6S	
RJ 10 Y	BP6S	
RJ 11	BR6S	
RJ 11 Y	BP5S	
RJ 12	BR6S	
RJ 12 Y	BP5S	
RJ 12 YC	BP5S	
RJ 14 CC	XR4	
RJ 14 Y	BP5S	



CHAMPION	→ NGK	Quick
RJ 17 LM	BR4-LM	
RJ 18 Y	BP-4	
RJ 19 LMC	BR2-LM	Q310
RJ 20 Y	BP-4	
RL 4 J	BR7HS	Q211
RL 7 J	BR6HS	Q209
RL 12 Y	BPR6HS	
RL 12 Y	BPR6HS	Q214
RL 12 Y	BPR6HS	
RL 19	BR5HS	
RL 77 J	BR7HS	Q211
RL 78	BR7HS	Q211
RL 82	BR6HS	Q209
RL 82 C	BR6HS	Q209
RL 82 Y	BPR6HS	
RL 82 Y	BPR6HS	Q214
RL 82 Y	BPR6HS	
RL 85	BR6HS	Q209
RL 86	BR6HS	Q209
RL 87 Y	BPR6HS	
RL 87 Y	BPR6HS	Q214
RL 87 Y	BPR6HS	
RL 87 YC	BPR6HS	
RL 87 YC	BPR6HS	Q214
RL 87 YC	BPR6HS	
RL 90	BR5HS	
RN 1 C	BR10ES	
RN 2	BR9ES	Q208
RN 2 G	BR9EIX	
RN 3	BR8ES	Q207
RN 3 G	BR8EIX	
RN 4	BR7ES	
RN 5	BR6ES	
RN 6	BR6ES	
RN 6 Y	BPR8ES	Q213
RN 7 GY	BPR7EIX	
RN 7 Y	BPR7ES	
RN 8	BR5ES	
RN 8 L	ZGR5C	
RN 9 BMC	BPR5EKU	
RN 9 GY	BPR6EIX	
RN 9 Y	BPR6ES	
RN 10 GY	BPR6EIX	
RN 10 PYP4	PGR5A-11	
RN 10 VTYC	BUR5ET	
RN 10 Y	BPR6ES	
RN 10 Y4	BPR6ES-11	
RN 11 Y	BPR5ES	
RN 12 GY	BPR5EIX	
RN 12 MC4	BPR4EY-11	
RN 12 Y	BPR5ES	
RN 12 YC4	BPR5ES-11	

CHAMPION	→ NGK	Quick
RN 12 YC6	BPR5ES-13	
RN 12 YCC	BPR5ES	
RN 13 L	ZGR5C	
RN 14 LY	ZGR5C	
RN 14 Y	BPR5ES	
RN 14 Y6	BPR5ES-13	
RN 16 Y	BPR4ES	
RN 16 YC6	BPR4EY-11	
RN 57 YC	BR10EG	
RN 74 C	BUR6EB-11	
RP 7	DR8HS	
RP 10 HC	DR5HS	
RS 12 YC6	BPR5EFS-13	
RS 13 LYC	TR4	
RS 14 LYC	TR4	
RS 14 PYP	TR4IX	
RS 16 YC	TR4	
RV 8 C	BR6FS	
RV 8 C6	BR6FS	
RV 12 C6	BR5FS	
RV 12 YC6	BPR5FS-15	
RV 15 YC	BPR4FS	
RV 91 MC	BR6FS	
RV 92 YC	BPR5FS	
RZ 7 C	CMR7H	
RZ 94 C	CR8HSA	
RZ 96 C	CR7HSA	
RZN 12 Y	BPR5EFS	
RZN 12 Y5	BPR5EFS	
S 59 C	R5724-9	
S 279 YC	BP6EFS	
S 281 YC	BP6EFS	
S 379 YC	BP7EFS	
UF 9 Y	AP6FS	
UF 11 Y	AP6FS	
UJ 2 J	B8S	
UJ 4 J	B7S	
UJ 6	B6S	Q302
UJ 8	B6S	Q302
UJ 12	B-2	
UJ 81 C	B7S	
UJ 81 J	B7S	
UK 10	AB-6	
UL 4 J	B7HS	Q204
UL 17 V	BUHXW-1	
UL 18 V	BUHX	
UL 77 V	BUHXW-1	
UL 81 C	B7HS	Q204
UL 81 J	B7HS	Q204
UL 82 Y	BP7HS	
UN 19 V	BUE	
UN 79 Y	BP6ES	



CHAMPION	→ NGK	Quick
V 4 C	B7FS	
V 9 YC	BP6FS	
V 12 YC	BP5FS	
V 61	R5673-8	
XC 12 PEPB	PZFR6H	
XC 92 YC	BKR5E	
XJ 10 Y	BP6S	
Y 82	CM-6	
Z 6	C8HSA	
Z 7 G	CR7HIX	
Z 8	C7HSA	
Z 9 Y	C7HSA	
Z 10	C6HSA	
Z 10 G	CR7HIX	
Z 12	C6HSA	

CHRYSLER	→ NGK	Quick
04606 402 AB	LZTR4A-11	
04606 591 AB	ZFR5LP-13G	
04886 204	BP5HS	
04886 205	BP5ES-A	
04886 206	BP6ES	
04886 207	BP5FS	
04886 208	BP4FS	
04886 210	BP5EFS	
04886 211	TR4	
04886 213	BPR5ES-11	
04886 214	BPR4ES-11	
04886 215	BCPR5ES	
04886 217	BPR5ES-A	
04886 219	BKR6ES	
04887 030	ZFR5F-11	
04887 031	BKR5ES-11	
04887 032	PFR5J-11	
S2LZT R4A 11	LZTR4A-11	
SP 149125 AD	ILZKR7B11GS	
SP 149125 AE	ILZKR7B11GS	

DENSO	→ NGK	Quick
3004	BPR5EP-11	
3005	BCPR5EIX-11	
3006	BCPR5EY-11	
3009	BCPR6EY-11	
3011	BP4EY	
3013	BPR4EY	
3018	BP5ES	
3025	B5ES	
3027	BP5EY	
3032	BPR5EY-11	
3034	B5HS	
3036	BP5S	

DENSO	→ NGK	Quick
3043	BP6ES	
3046	BUR6EA-11	
3049	BPR6ES-11	
3051	B6ES	
3062	BP6EY	
3066	BPR6EY	
3067	BPR6EY-11	
3068	BP6HS	
3070	BPR6HS	
3070	BPR6HS	Q214
3070	BPR6HS	
3073	B6HS	Q203
3074	BR6HIX	
3075	B6S	Q302
3085	BP7ES	Q206
3088	BPR7ES	
3089	BPR7ES-11	
3093	B7ES	
3095	BR7EIX	
3098	BR7ES	
3103	BR8ET	
3107	BR9ET	
3110	BR5ES	
3111	SD11A	
3112	ZFR6A-11	
3113	BCPR6EP-N-8	
3114	PGR5A-11	
3115	PGR6A-11	
3117	BCPR6EP-11	
3119	BKR5EYA	
3120	BKR5EYA-11	
3121	BKR6E-11	
3122	BKR6EYA	
3123	BCPR5EP-8	
3125	BCP6ES	
3127	BKR6EP-8	
3128	BKR6EP-11	
3129	BCPR5EY	
3130	BKR5E-11	
3131	ZFR5J-11	
3132	ZFR5F-11	
3133	ZFR6J-11	
3134	BKR5EP-11	
3135	ZFR5E-11	
3139	BKR6EY-11	
3140	BCPR6EY	
3141	PFR6J-11	
3142	PFR6G-11	
3144	BKR6E-N-11	
3156	BCPR5EIX-11	
3157	BCPR6EIX-11	
3158	BCPR7EIX	



DENSO	→ NGK	Quick
3161	BKR5EIX-11	
3163	BKR6EIX-11	
3165	BKR7E	
3167	ZFR4F-11	
3168	PFR6B-11	
3172	PFR6G-13	
3174	PFR5J-11	
3175	PZFR5F	
3179	DCPR7E	
3184	BCPR5EY-11	
3186	BCPR5EY-11	
3187	BCPR6EY-11	
3192	BKR7E-11	
3194	BKR5EKB-11	
3195	BKR6EKB-11	
3196	BKUR6EK	
3197	BKUR7EK	
3199	BP5EY-11	
3201	BPR5ES-11	
3210	BPR5EY	
3213	BPR5ES-13	
3226	BKR6EP-13	
3231	BPR5EIX	
3235	BCRE527Y	
3239	BPR5EP-11	
3242	DCPR7EIX	
3244	BCPR6EIX-11	
3245	PFR6J	
3246	PZFR5F-11	
3247	PZFR6F-11	
3253	BKR6EKPB-11	
3255	BCP7ES	
3256	ZGR5A	
3262	BKR6EIX-11	
3264	PFR5B-11	
3273	PFR7B	
3275	PFR5G-11	
3277	BPR6EKN	
3281	BPR7EIX	
3285	BPR5EIX-11	
3289	BKR5EKPB-11	
3290	BKR7EIX	
3291	BPR6EIX	
3293	BKR5EIX	
3297	IFR6T11	
3299	BKR7E-N-11	
3301	BKR5EIX-P	
3302	PGR7A	
3303	IFR5T-8N	
3304	BKR6EKC	
3305	BKUR6EK-9	
3306	PGR6A	

DENSO	→ NGK	Quick
3307	IFR6C	
3310	BR10ET	
3312	DCPR8E	
3313	DCPR9E	
3314	DCPR9EIX	
3323	BPR6EIX-11	
3333	BKR6E	
3344	BPR6ES	
3345	BPR5ES	
3346	BCPR5E	
3347	BCPR7ES	
3348	ZFR7F-11	
3349	BKR5E	
3353	BKR5EIX-11P	
3354	IGR7A	
3372	IFR7G-11KS	
3373	BKR6EP-8	
3374	ZFR6K-11	
3377	IZFR6K11	
3378	ZFR6FIX-11	
3379	BCPR7ES-11	
3380	BKR6EKPA	
3381	LFR6C-11	
3398	BKR6EIX-11P	
3400	IFR5E11	
3403	IFR6S	
3412	IFR5E11	
3413	ZFR5F	
3418	IFR6E11	
3424	BKR6E	
3427	LZKAR7A	
3432	IZFR6K11NS	
3434	IKR7C	
3437	FR5EI	
3439	DILKAR6A11	
3441	ILKR7B8	
3444	ILKAR7B11	
3449	IFR6J11	
4019	BP5HS	
4021	BP7HS	
4025	B7HS	Q204
4026	BR7HIX	
4027	B7S	
4028	BP8ES	
4030	B8ES	Q201
4032	BR8EIX	
4048	BR9EIX	
4057	BR10EIX	
4093	DP8EA-9	
4097	DPR8EIX-9	
4136	BPR8ES	Q213
4167	DR8EIX	



DENSO	→ NGK	Quick
4172	DR9EIX	
4189	CR8EIX	
4201	CR7EK	
5008	APR5FS	
5012	AP6FS	
5013	APR6FS	
5022	BPR5EFS	
5027	BPR5FS-15	
5031	BP6EFS	
5032	BPR6EFS	
5035	BPR6FS	
5040	BP7EFS	
5060	BKUR6ET	
5061	BKUR6ET-10	
5061	BKUR6ET-10	
5062	BKUR7ET	
5063	BKR6EKUB	
5064	BP5ET-10	
5065	BUR6ET	
5066	BP7ET	
5067	BUR6ET	
5068	PTR5A-13	
5069	BCP7ET	
5070	PTR5D-10	
5077	PZTR5A-15	
5301	BCPR5EIX-11	
5302	BCPR6EIX-11	
5303	BKR5EIX-11	
5304	BKR6EIX-11	
5305	BPR5EIX-11	
5306	BPR6EIX-11	
5307	BPR7EIX	
5308	DCPR7EIX	
5310	IRIWAY7	
5311	IRIWAY8	
5312	IRIWAY9	
5313	IRITOP7	
5316	BR8EIX	
5317	BR9EIX	
5325	TR5IX	
5326	TR6IX	
5327	TR7IX	
5328	TR8IX	
5330	UR5IX	
5331	UR6IX	
5337	IRIMAC9	
5343	LFR5AIX-11	
5344	LFR6AIX-11	
5361	CR7EIX	
5362	CR8EIX	
5372	DR8EIX	
5376	DPR8EIX-9	

DENSO	→ NGK	Quick
5378	BPR6HIX	
5379	BR7HIX	
5601	BCPR5EIX-11P	
5602	BCPR6EIX-11P	
5603	BKR5EIX-11P	
5604	IZFR6H11	
5608	DCPR7EIX-P	
5615	IFR6L11	
5616	IFR8H11	
5617	ILZFR5B	
5618	ILZFR6D11	
5619	LFR7AIX-P	
5620	BKR6EIX-P	
5623	HB6AIX-11P	
5625	HB6BIX-11P	
5630	IFR9H11	
5639	LFR6AIX-P	
5719	R7420-9	
5720	R7420-10	
6054	B6HS	Q203
6076	LFR5A-11	
P 16 R	BPR5EP-11	
PQ 16 R	BCPR5EIX-11	
Q 16 R-U 11	BCPR5EY-11	
Q 20 R-U 11	BCPR6EY-11	
W 14 EX-U	BP4EY	
W 14 EXR-U	BPR4EY	
W 16 EP-U	BP5ES	
W 16 ES-U	B5ES	
W 16 EX-U	BP5EY	
W 16 EXR-U 11	BPR5EY-11	
W 16 FS-U	B5HS	
W 16 P-U	BP5S	
W 20 EP-U	BP6ES	
W 20 EPR-S 11	BUR6EA-11	
W 20 EPR-U 11	BPR6ES-11	
W 20 ES-U	B6ES	
W 20 EX-U	BP6EY	
W 20 EXR-U	BPR6EY	
W 20 EXR-U11	BPR6EY-11	
W 20 FP-U	BP6HS	
W 20 FPR-U	BPR6HS	Q214
W 20 FPR-U	BPR6HS	
W 20 FS-U	B6HS	Q203
W 20 FSZ-U	BR6HIX	
W 20 S-U	B6S	Q302
W 22 EP-U	BP7ES	Q206
W 22 EPR-U	BPR7ES	
W 22 EPR-U 11	BPR7ES-11	
W 22 ES-U	B7ES	
W 22 ESZ-U	BR7EIX	



DENSO	→ NGK	Quick
W 22 ESR-U	BR7ES	
W 25 EBR	BR8ET	
W 27 EBR	BR9ET	
W 16 ESR-U	BR5ES	
S-31 A	SD11A	
QJ 20 CR 11	ZFR6A-11	
PQ 20 R-P 8	BCPR6EP-N-8	
P 16 PR 11	PGR5A-11	
P 20 PR 11	PGR6A-11	
PQ 20 R	BCPR6EP-11	
K 16 R-U	BKR5EYA	
K 16 R-U 11	BKR5EYA-11	
K 20 PR-U 11	BKR6E-11	
K 20 R-U	BKR6EYA	
PQ 16 R 8	BCPR5EP-8	
Q 20 P-U	BCP6ES	
PK 20 R 8	BKR6EP-8	
PK 20 R 11	BKR6EP-11	
Q 16 R-U	BCPR5EY	
K 16 PR-U 11	BKR5E-11	
KJ 16 CR 11	ZFR5J-11	
KJ 16 CR-L 11	ZFR5F-11	
KJ 20 CR 11	ZFR6J-11	
PK 16 R 11	BKR5EP-11	
K 16 GPR-U 11	ZFR5E-11	
K 20 R-U 11	BKR6EY-11	
Q 20 R-U	BCPR6EY	
PK 20 PR-P 11	PFR6J-11	
PK 20 PR-L 11	PFR6G-11	
K 20 PR-L 11	BKR6E-N-11	
Q 16 PRZ-U 11	BCPR5EIX-11	
Q 20 PRZ-U 11	BCPR6EIX-11	
Q 22 PRZ-U	BCPR7EIX	
K 16 PRZ-U 11	BKR5EIX-11	
K 20 PRZ-U 11	BKR6EIX-11	
K 22 PR-U	BKR7E	
KJ 14 CR-L 11	ZFR4F-11	
PK 20 PR 11	PFR6B-11	
PK 20 PR-L 13	PFR6G-13	
PK 16 PR-P 11	PFR5J-11	
PKJ 16 CR 8	PZFR5F	
XU 22 EPR-U	DCPR7E	
Q 16 P-U 11	BCPR5EY-11	
Q 16 PR-U 11	BCPR5EY-11	
Q 20 PR-U 11	BCPR6EY-11	
K 22 PR-U 11	BKR7E-11	
K 16 TR 11	BKR5EKB-11	
K 20 TR 11	BKR6EKB-11	
K 20 TNR-S	BKUR6EK	
K 22 TNRS	BKUR7EK	
W 16 EP-U 11	BP5EY-11	
W 16 EPR-U 11	BPR5ES-11	

DENSO	→ NGK	Quick
W 16 EXR-U	BPR5EY	
W 16 EXR-U 13	BPR5ES-13	
PK 20 R 13	BKR6EP-13	
W 16 EXRZ-U	BPR5EIX	
QJ 16 AR-U	BCRE527Y	
P 16 R 13	BPR5EP-11	
XU 22 EPRZ-U	DCPR7EIX	
PQ 20 R 13	BCPR6EIX-11	
PK 20 PR-P 8	PFR6J	
PKJ 16 CR-L 11	PZFR5F-11	
PKJ 20 CR-L 11	PZFR6F-11	
PK 20 TR 11	BKR6EKP-11	
Q 22 P-U	BCP7ES	
J 16 CR-U	ZGR5A	
K 20 PR-TP 11	BKR6EIX-11	
PK 16 PR 11	PFR5B-11	
PK 22 PR 8	PFR7B	
PK 16 PR-L 11	PFR5G-11	
W 20 ETR-L	BPR6EKN	
W 22 EPRZ-U	BPR7EIX	
W 16 ETRS	BPR5EIX-11	
PK 16 TR 11	BKR5EKP-11	
K 22 PRZ-U	BKR7EIX	
W 20 EPRZ-U	BPR6EIX	
K 16 PR-P 11	BKR5EIX	
SK 20 R 11	IFR6T11	
K 22 PR-L 11	BKR7E-N-11	
PK 16 R 8	BKR5EIX-P	
P 22 PR 8	PGR7A	
SK 16 R-P 8	IFR5T-8N	
K 20 TNR	BKR6EKC	
K 20 TNRS 9	BKUR6EK-9	
P 20 PR 8	PGR6A	
SK 20 PR-L9	IFR6C	
W 29 EBR	BR10ET	
XU 24 EPR-U	DCPR8E	
XU 27 EPR-U	DCPR9E	
XU 27 EPRZ-U	DCPR9EIX	
W 20 EPRZ-U 11	BPR6EIX-11	
K 20 PR-U	BKR6E	
W 20 EPR-U	BPR6ES	
W 16 EPR-U	BPR5ES	
Q 16 PR-U	BCPR5E	
Q 22 PR-U	BCPR7ES	
KJ 22 CR-L 11	ZFR7F-11	
K 16 PR-U	BKR5E	
SK 16 R-P 11	BKR5EIX-11P	
S 22 PR-A 7	IGR7A	
SK 22 PR-M 11	IFR7G-11KS	
SVK 20 RZ 8	BKR6EP-8	
KJ 20 DR-M 11	ZFR6K-11	
SKJ 20 DR-M 11	IZFR6K11	



DENSO	→ NGK	Quick
KJ 20 SR 11	ZFR6FIX-11	
Q 22 PR-U 11	BCPR7ES-11	
PK 20 PTR-S 9	BKR6EKPA	
K 20 HR-U 11	LFR6C-11	
SK 20 R-P 11	BKR6EIX-11P	
SK 16 PR-A 11	IFR5E11	
SK 20 PR-A8	IFR6S	
SK 16 PR-E11	IFR5E11	
KJ 16 CR	ZFR5F	
SK 20 PR-A 11	IFR6E11	
Q 20 PR-U	BKR6E	
XE 20 HR-U 9	LZKAR7A	
SKJ 20 DR-M 11 S	IZFR6K11NS	
SXU 22 PR 9	IKR7C	
K 16 PSR-B 8	FR5EI	
FXE 20 HR 11	DILKAR6A11	
SXU 22 HDR 8	ILKR7B8	
SC 20 HR 11	ILKAR7B11	
SVK 20 RZ 11	IFR6J11	
W 16 FP-U	BP5HS	
W 22 FP-U	BP7HS	
W 22 FS-U	B7HS	Q204
W 22 FSZ-U	BR7HIX	
W 22 S-U	B7S	
W 24 EP-U	BP8ES	
W 24 ES-U	B8ES	Q201
W 24 ESZ-U	BR8EIX	
W 27 ESZ-U	BR9EIX	
W 29 ESZ-U	BR10EIX	
X 24 EP-U 9	DP8EA-9	
X 24 EPRZ-U 9	DPR8EIX-9	
W 24 EPR-U	BPR8ES	Q213
X 24 ESRZ-U	DR8EIX	
X 27 ESRZ-U	DR9EIX	
U 24 ESRNZ-U	CR8EIX	
U 22 ETR	CR7EK	
MA 16 PR-U	APR5FS	
MA 20 P-U	AP6FS	
MA 20 PR-U	APR6FS	
T 16 EPR-U	BPR5EFS	
T 16 PR-U 15	BPR5FS-15	
T 20 EP-U	BP6EFS	
T 20 EPR-U	BPR6EFS	
T 20 PR-U	BPR6FS	
T 22 EP-U	BP7EFS	
K 20 PBR	BKUR6ET	
K 20 PBR-S 10	BKUR6ET-10	
K 20 PBR-S 10	BKUR6ET-10	
K 22 PBR-S	BKUR7ET	
K 20 TXR	BKR6EKUB	
W 16 EPB 10	BP5ET-10	
W 20 EPB	BUR6ET	

DENSO	→ NGK	Quick
W 22 EPB	BP7ET	
W 20 EPBR-S	BUR6ET	
PT 16 VR 13	PTR5A-13	
K 22 PB	BCP7ET	
PT 16 EPR-L 13	PTR5D-10	
PTJ 16 R 15	PZTR5A-15	
IQ 16	BCPR5EIX-11	
IQ 20	BCPR6EIX-11	
IK 16	BKR5EIX-11	
IK 20	BKR6EIX-11	
IW 16	BPR5EIX-11	
IW 20	BPR6EIX-11	
IW 22	BPR7EIX	
IXU 22	DCPR7EIX	
IK 22	IRIWAY7	
IK 24	IRIWAY8	
IK 27	IRIWAY9	
IQ 22	IRITOP7	
IW 24	BR8EIX	
IW 27	BR9EIX	
IT 16	TR5IX	
IT 20	TR6IX	
IT 22	TR7IX	
IT 24	TR8IX	
ITF 16	UR5IX	
ITF 20	UR6IX	
IXU 27	IRIMAC9	
IKH 16	LFR5AIX-11	
IKH 20	LFR6AIX-11	
IU 22	CR7EIX	
IU 24	CR8EIX	
IX 24	DR8EIX	
IX 24 B	DPR8EIX-9	
IWF 20	BPR6HIX	
IWF 22	BR7HIX	
VQ 16	BCPR5EIX-11P	
VQ 20	BCPR6EIX-11P	
VK 16	BKR5EIX-11P	
VK 20	IZFR6H11	
VXU 22	DCPR7EIX-P	
VK 20 PRZ 11	IFR6L11	
VK 24 PRZ 11	IFR8H11	
VKH 16	ILZFR5B	
VKH 20	ILZFR6D11	
VKH 22	LFR7AIX-P	
VK 20 Y	BKR6EIX-P	
VKA 20	HB6AIX-11P	
VKB 20	HB6BIX-11P	
VK 27 PRZ 11	IFR9H11	
VKH 20 Y	LFR6AIX-P	
IRE 01-27	R7420-9	
IRE 01-31	R7420-10	



DENSO	→ NGK	Quick
TR 20	B6HS	Q203
K 16 HPR-U 11	LFR5A-11	
DK 20 PR-D13	DIFR6A13G	
DXE 22 HCR 11 S	DILZKAR7C11S	
FK 20 HBR 11	DFH6B-11A	
FXE 22 HR 11	DF7H-11B	
FXE 24 HR 11	DF8H-11B	
IA 01-32	R7282A-105	
IA 01-34	R7282A-11	
IAE 01-32	R7282-105	
IAE 01-34	R7282-11	
IK 01-24	R7434-8	
IK 01-27	R7434-9	
IK 01-31	R7434-10	
IK 02-24	R7434-8	
IK 02-27	R7434-9	
IK 02-31	R7434-10	
IK 20 TT	DIFR6A13G	
IK 24 C 11	FR8BI-11	
IK 27 C 11	FR9BI-11	
IKH 01-24	R7438-8	
IKH 01-27	R7438-9	
IKH 01-31	R7438-10	
IKH 20 TT	DILFR6A11	
IQ 01-24	R7436-8	
IQ 01-27	R7436-9	
IQ 01-31	R7436-10	
IQ 02-24	R7436-8	
IQ 02-27	R7436-9	
IQ 02-31	R7436-10	
IQ 24	IRITOP8	
IQ 27	IRITOP9	
IRE 01-32	R7420-105	
IRE 01-34	R7420-11	
IU 01-27	R0373A-9	
IU 01-31	R0373A-10	
IU 01-34	R0373A-11	
IU 27	B8HCS	
IU 27 D	CR9EIA-9	
IUF 22	CR7HIX	
IUF 24	CR8HIX	
IUH 24	CR8EHIX-9	
IUH 27	CR9EHIX-9	
IUH 27 D	IMR9A-9H	
IW 01-24	R7376-8	
IW 01-27	R7376-9	
IW 01-31	R7376-10	
IW 06-27	R7376-9	
IW 06-31	R7376-10	
IW 31	BR10EIX	
IWF 24	BR8HIX	
IWF 27	BR9HIX	

DENSO	→ NGK	Quick
IWM 01-32	R7282-105	
IWM 24	BR8ECMIX	
IWM 27	BR9ECMIX	
IWM 31	BR10ECMIX	
IX 22	DR7EIX	
IX 22 B	DPR7EIX-9	
IX 27	DR9EIX	
IX 27 B	DPR9EIX-9	
IXU 01-27	R2525-9	
IXU 01-31	R2525-10	
IXU 01-34	R2349-11	
IXU 22 C	KR7AI	
IY 24	ER8EHIX	
IY 27	ER9EHIX	
J 16 AR-U 11	BRE527Y-11	
J 16 A-U 11	BE527Y-11	
J 16 AY	BPR5EY-11	
J 16 AYR	BPR5EJ	
J 16 BR-U	BRE529Y	
J 16 BR-U 11	BRE529Y-11	
J 16 B-U 11	BE529Y-11	
J 16 C-U	BPR5EY	
J 20 AY	BPR6EY-11	
K 14 PR-U 11	BKR4E-11	
K 14 P-U 11	BKR5E-11	
K 16 DTR-S 11	ZFR5G	
K 16 PR-L 11	BKR5E-N-11	
K 16 PR-TP 11	BKR5EIX-11	
K 16 PRUR	BKR5E	
K 16 P-U	BK5E	
K 16 P-U 11	BK5E-11	
K 16 RZ-U 11	BKR5EIX-11	
K 16 TNRS 9	BKR5EKC	
K 16 U	BKR5EYA	
K 16 U 11	BKR5EYA-11	
K 20 DTR-S 11	ZFR6G	
K 20 HR-U	LFR6B	
K 20 HR-U	LFR6B	
K 20 PR-U 9 S	BKR6E-9S	
K 20 PRUR	BKR6E	
K 20 PSR-B 8	FR6EI	
K 20 P-U	BK6E	
K 20 P-U 11	BK6E-11	
K 20 RZ	BKR6EIX	
K 20 RZ-U 11	BKR6EIX-11	
K 20 TMR 11	BKR6EKC-N-11	
K 20 TRX	BKR6EJU	
K 20 TT	ZFR6U-9	
K 20 U	BKR6EYA	
K 20 U 11	BKR6EYA-11	
K 22 P 11	BK7EK-N-11	
K 22 PR-TP 11	BKR7EIX-11	



DENSO	→ NGK	Quick
K 22 PRUR	BKR7E	
K 22 PRZ-U 11	BKR7EIX-11	
K 22 TM 11	BK7EK-N-11	
K 22 TMR	BKR7EKC-N	
K 22 TMR 11	BKR7EKC-N-11	
K 22 TNR	BKR7EKC	
K 24 PR-U 11	BKR8E-11	
K 29 AZ	R7434-10	
KJ 14 CR 11	ZFR4F-11	
KJ 16 CR-U 11	ZFR5F-11	
KJ 20 CR-U 11	ZFR6F-11	
KJ 22 CR 11	ZFR7F-11	
KJ 22 CR-L 8	ZFR7F	
KJ 206 CR-L 11	ZFR6F-11	
L 14 U	AB-6	
M 17	AB-6	
M 22	AB-7	
M 24 S	AB-8	
MA 14 P-U	AP5FS	
MA 16 PR-U 11	APR5FS	
MA 16 PR-U 15	APR5FS	
MA 16 P-U	AP5FS	
MA 17 P-U	AP6FS	
MA 20 R-U	AR6FS	
MA 20 R-U 11	AR6FS	
MW 9	AB-2	
MW 17	AB-6	
MW 22	AB-7	
P 16 PR 8	PGR5A	
P 20 R 8	BPR6EP-8	
PK 16 TR 13	BKR5EKP-13	
PK 20 GR 8	BKR6EPA-8	
PK 20 PRP	PFR6J	
PK 20 PRTP	PFR6M	
PK 22 PR 11	PFR7B-11	
PK 22 PR-L 11	PFR7G-11	
PK 22 PR-L 11 S	PFR7G-11S	
PK 22 PRTP	PFR7M	
PKJ 16 CR-L 13	PZFR5F-13	
PKJ 20 CR 8	PZFR6F	
PKJ 20 CR-M 11	PZFR6F-11	
PQ 16 R 13	BCPR5EIX-11	
PQ 20 R-P 11	BCPR6EIX-11	
PT 16 EPR-C 13	PTR5C-13	
Q 14 R-U 11	BCPR4EY-11	
Q 16 PR-TP 11	BCPR5EIX-11	
Q 16 RZ-U 11	BCPR5EIX-11	
Q 16 U 11	BCPR5EY-11	
Q 16 Z-U 11	BCPR5EIX-11	
Q 20 PR-P 11	BCPR6EIX-11	
Q 20 PRU-L 11	BCPR6EY-N-11	
Q 20 P-U 11	BKR6E-11	

DENSO	→ NGK	Quick
Q 20 RZ-U 11	BCPR6EIX-11	
Q 20 U	BCP6E	
Q 20 U 11	BKR6E-11	
Q 20 Z-U 11	BCPR6EIX-11	
Q 22 PR-P 11	BKR7EIX-11	
Q 22 PRU-L 11	BCPR7EY-N-11	
Q 22 PRZ-U 11	BKR7EIX-11	
Q 22 P-U 11	BKR7E-11	
Q 27 AZ	R7435-9	
QJ 16 C 11	ZFR5A-11	
QJ 16 CR 11	ZFR5A-11	
QJ 22 CR 11	ZFR7F-11	
QL 20 PR-U	BCPR6ED	
QL 20 TRS	BCPR6EKD	
QL 22 TRS	BCPR7EKD	
RU 01-31	R0045Q-10	
RU 01-34	R0045Q-11	
S-29 A	SD10A	
SD 29 A	SD10A	
SF 10	BUHX	
SF 24	BU8H	
SF 50	BUHW	
SF 51	BUHW-2	
SK 16 PR-E13	IFR5E13	
SK 16 PR-L 11	IFR5G-11K	
SK 20 BGR 11	HB6AIX-11P	
SK 20 BR 11	HB6BIX-11P	
SK 20 HPR-L 11	ILFR6J-11K	
SK 20 HR 11	ILFR6T11	
SK 20 R 8-G	LPG1	
SKJ 16 DR-M 11	IZFR5K11	
SKJ 20 DR-M 13	IZFR6K13	
SXU 22 HCR 11 S	ILZKR7B11GS	
T 14 PR-U	BPR4FS	
T 14 PR-U 15	BPR4FS-15	
T 16 EX-U	BP5EFS	
T 16 PR-U	BPR5FS	
T 16 PR-U 11	BPR5FS-11	
T 16 P-U	BP5FS	
T 16 R-U	BR5FS	
T 16 RU 15	BR5FS	
T 16 U 15	YR55IX	
T 20 EPR-U 15	BPR6EFS-15	
T 20 EPU 15	BPR6EFS-15	
T 20 EX-U	BP6EFS	
T 20 MP-U	BPM6F	
T 20 M-U	BM6F	
T 20 PR-U 15	BPR6FS	
T 20 P-U	BP6FS	
T 20 R-U	BR6FS	
T 20 R-U 15	BR6FS	
T 22 MP-U	BPM7F	

DENSO	→ NGK	Quick
T 22 M-U	BM7F	
TR 22	B7HS	Q204
TR 22-10	B7HS-10	
TR 24	B8HS	Q205
TR 24-10	B8HS-10	
U 14 FSRUB	CR4HSB	
U 14 FSUB	C4HSB	
U 16 FER-9	CR5EH-9	
U 16 FSL	C5HSA	
U 16 FSRL	CR5HSA	
U 16 FSR-U	CR5HSA	
U 16 FSRUB	CR5HSB	
U 16 FS-U	C5HSA	
U 16 FSUB	C5HSB	
U 17 F	C5HSA	
U 20 EPR-9	CPR6EA-9	
U 20 ESR-N	CR6E	
U 20 FS	C6HSA	
U 20 FSL	C6HSA	
U 20 FSRL	CR6HS	Q223
U 20 FSR-U	CR6HSA	
U 20 FS-U	C6HSA	
U 20 M-U	CM-6	
U 21 FB	C6HSA	
U 22 EPR-U	CPR7EA-9	
U 22 ESN	C7E	
U 22 ESRN	CR7E	Q225
U 22 FER 9	CR7EH-9	
U 22 FS	C7HSA	
U 22 FSG-U	CR7HIX	
U 22 FSL	C7HSA	
U 22 FSRL	CR7HS	
U 22 FSR-U	CR7HSA	
U 22 FS-U	C7HSA	
U 22 FSZ-U	CR7HIX	
U 24 ESN	C8E	
U 24 ESRN	CR8E	Q226
U 24 ESRNB	CR8EB	
U 24 ETR	CR8EK	
U 24 FB	C8HSA	
U 24 FE 9	C8EH-9	
U 24 FER 9	CR8EH-9	Q228
U 24 FER 9 S	CR8EH-9S	
U 24 FERZ-U 9	CR8EHIX-9	
U 24 FS	C8HSA	
U 24 FSL	C8HSA	
U 24 FSRC	LR8A	
U 24 FSR-U	CR8HS	
U 24 FS-U	C8HSA	
U 27 ESN	C9E	
U 27 ESNZ-U	CR9EIX	
U 27 ESRN	CR9E	Q227

DENSO	→ NGK	Quick
U 27 ESRNB	CR9EB	
U 27 ESRNZ-U	CR9EIX	
U 27 ETR	CR9EK	Q230
U 27 FE 9	C9EH-9	
U 27 FER 9	CR9EH-9	Q229
U 27 FERZ-U 9	CR9EHIX-9	
U 27 FEZ-U 9	CR9EHIX-9	
U 31 ESRN	CR10E	
U 31 ETR	CR10EK	
VFXEHC 22 G	DILZKAR7C11S	
VK 16 J	ZFR5FIX-11P	
VK 16 PRZ 11	IFR5L11	
VK 20 T	LPG1	
VK 22	IFR7F-6D	
VK 22 G	BKR7EIX-11PS	
VK 22 PRZ 11	IFR7L11	
VKJ 20 RZ-M 11	IZFR6F11	
VNH 27 Z	IMR9B-9H	
VUH 24 D	IMR8C-9H	
VUH 27 D	IMR9C-9H	
VUH 27 ES	IMR9C-9HES	
VUH 27 Z	IMR9A-9H	
VW 20 T	LPG2	
VX 22 BC	IJR7A9	
VX 22 BZ	IJR7A9	
W 9	B-2	
W 9 EP	BP-2E	
W 9 EPR	BPR2ES	
W 9 EXR-U	BPR2ES	
W 9 EX-U	BP-2E	
W 9 FP	BP-2H	
W 9 FPL	BP2HS	
W 9 FPLUL	BP2HS	
W 9 FPUL	BP2HS	
W 9 LMRUS	BR2-LM	Q310
W 9 LMUS	B2-LM	
W 9 P	BP-4	
W 9 PR-U	BP-4	
W 9 P-U	BP-4	
W 9 U	B-2	
W 14	B-4	
W 14 E	B4ES	
W 14 EKR-S 11	BUR4EB-11	
W 14 EP	BP4ES	
W 14 EPR	BPR4ES	
W 14 EPR 11	BPR4ES-11	
W 14 EPR-U	BPR4ES	
W 14 EP-U	BP4ES	
W 14 EXR-U 11	BPR4EY-11	
W 14 EXR-U 13	BPR4ES-13	
W 14 EX-U 11	BP4EY-11	
W 14 EX-U 13	BPR4ES-13	



DENSO	→ NGK	Quick
W 14 F	B-4H	
W 14 FP	BP-4H	
W 14 FPL	BP4HS	
W 14 FPLUL	BP4HA	
W 14 FPR	BPR-4H	
W 14 FPRL	BPR4HS	
W 14 FPR-U	BPR-4H	
W 14 FPR-UL	BPR4HS	
W 14 FPR-UL 10	BPR4HS-10	
W 14 FP-U	BP-4H	
W 14 FP-UL	BP4HS	
W 14 FP-UL 10	BP4HS-10	
W 14 FRL	BR4HSA	
W 14 FR-U	BR4HS	
W 14 F-U	B-4H	
W 14 F-U 10	B-4H-10	
W 14 L	B-4L	
W 14 LMR-US	BR4-LM	
W 14 LM-U	B4-LM	Q301
W 14 LM-US	B4-LM	Q301
W 14 MPR-U 10	BPMR4A	
W 14 MR-U	BMR4A	Q306
W 14 M-U	BM4A	
W 14 M-US	BM4A	
W 14 P	BP5S	
W 14 PR-U	BP-4	
W 14 P-U	BP-4	
W 14 U	B-4	
W 14 U 10	B-4	
W 14 US	B-4	
W 16 DTRS	BPR5EKB	
W 16 EKR-S 11	BUR5EB-11	
W 16 EK-S 11	BUR5EB-11	
W 16 EP	BP5ES	
W 16 E-P 11	BP5ES-11	
W 16 EPB	BP5EY	
W 16 EPG-U	BPR5EIX	
W 16 EPR	BPR5ES	
W 16 EPR 11	BPR5ES-11	
W 16 EPR-S 11	BUR5EA-11	
W 16 EPR-U 10	BPR5E-11	
W 16 EP-U 10	BP5ES-11	
W 16 EPZ-U	BPR5EIX	
W 16 ES	B5ES	
W 16 ES-L 11	BR5ES	
W 16 ESRL	BR5ES	
W 16 ESR-L 11	BUR5EB-11	
W 16 ETL	BPR5EY	
W 16 EX	BP5EY	
W 16 EX-U 11	BP5EY-11	
W 16 EX-U 13	BP5ES-13	
W 16 EXZ-U	BPR5EIX	

DENSO	→ NGK	Quick
W 16 FP	BP5HS	
W 16 FPR	BPR5HS	
W 16 FPR-U	BPR5HS	
W 16 FPU 10	BP5HS-10	
W 16 FS	B5HS	
W 16 FSR	BR5HS	
W 16 LS	B-6L	
W 16 PR-U	BP5S	
W 17	B6S	Q302
W 17 ES	BR6ES	
W 17 FP	BP6HS	
W 17 P	BP6S	
W 17 PR-U	BP6S	
W 17 P-U	BP6S	
W 20 DTRSA	BPR6EKB-L	
W 20 EKR-S 11	BUR6EB-11	
W 20 EK-S 11	BUR6EB-11	
W 20 EP	B6ES	
W 20 E-P 11	BP6ES-11	
W 20 EPG-U	BPR6EIX	
W 20 EPR	BPR6ES	
W 20 EPR 11	BPR6ES-11	
W 20 EPR-U 10	BPR6ES-11	
W 20 EP-S 11	BUR6EA-11	
W 20 EP-U 10	BP6ES-11	
W 20 EP-U 11	BP6ES-11	
W 20 EPZ-U	BPR6EIX	
W 20 ES	B6ES	
W 20 ESL	BR6ES	
W 20 ES-L 11	BUR6EB-11	
W 20 ESR	BR6ES	
W 20 ESRL	BR6ES	
W 20 ESR-L 11	BUR6EB-11	
W 20 ES-U 11	B6ES-11	
W 20 ET	BPR6EK-A	
W 20 ETL	BPR6EKN	
W 20 ETR	BPR6EK-A	
W 20 ETR-L 8	BPR6EKN	
W 20 ETRS	BPR6EK-A	
W 20 ETS	BPR6EK-A	
W 20 EXR-U 13	BPR6EIX-11	
W 20 EXRZ-U	BPR6EIX	
W 20 EX-U 11	BP6EY-11	
W 20 EXZ-U	BPR6EIX	
W 20 FP	BP6HS	
W 20 FPL	BP6HSA	
W 20 FPR	BPR6HS	
W 20 FPR	BPR6HS	Q214
W 20 FPR	BPR6HS	
W 20 FPRL	BPR6HSA	
W 20 FPR-U 10	BPR6HS-10	
W 20 FPRU-L 10	BPR6HS-10	



DENSO	→ NGK	Quick
W 20 FP-U 10	BP6HS-10	
W 20 FRL	BR6HSA	Q210
W 20 FS	B6HS	Q203
W 20 FSG-U	BR6HIX	
W 20 FSR	BR6HS	Q209
W 20 FSR-U	BR6HS	Q209
W 20 FSU 10	B6HS-10	
W 20 M	BM6A	Q303
W 20 MPRU 10	BPMR6A-10	
W 20 MP-U	BPM6A	Q304
W 20 MPU 10	BPM6A-10	
W 20 MR-U	BMR6A	Q307
W 20 M-U	BM6A	Q303
W 20 MUS	BM6A	Q303
W 20 PR-U	BP6S	
W 20 P-U	BP6S	
W 20 S	B6S	Q302
W 20 SR-U	BR6S	
W 21 ES-L 11	BR6EB-L-11	
W 21 ESR-L 11	BR6EB-L-11	
W 22	B7S	
W 22 EA	B7EM	
W 22 EB	BR7ET	
W 22 EBR	BR7ET	
W 22 EKR-S 11	BUR7EB-11	
W 22 EK-S 11	BUR7EB-11	
W 22 EP	BP7ES	Q206
W 22 E-P 11	BP7ES-11	
W 22 EPG-U	BPR7EIX	
W 22 EPR	BPR7ES	
W 22 EPR 11	BPR7ES-11	
W 22 EPR-S 11	BUR7EA-11	
W 22 EP-S 11	BUR7EA-11	
W 22 EP-U 11	BP7ES-11	
W 22 EPZ-U	BPR7EIX	
W 22 ES	B7ES	
W 22 ESG-U	BR7EIX	
W 22 ESL	BR7ES	
W 22 ES-L 11	BUR7EB-11	
W 22 ESR	BR7ES	
W 22 ESRL	BR7ES	
W 22 ESR-L 11	BUR7EB-11	
W 22 ES-U 11	B7ES-11	
W 22 ETL	BPR7EKN	
W 22 ETRL	BPR7EKN	
W 22 ETR-L 8	BPR7EKN	
W 22 EXR-U	BPR7EIX	
W 22 EXR-U 11	BPR7EY-11	
W 22 EX-U	BP7EY	
W 22 FP	BP7HS	
W 22 FPR	BPR7HS	Q215
W 22 FPR-U	BPR7HS	Q215

DENSO	→ NGK	Quick
W 22 FPRZ-U	BPR7HIX	
W 22 FP-U 10	BP7HS-10	
W 22 FPUS	BP7HS	
W 22 FS	B7HS	Q204
W 22 FSG-U	BR7HIX	
W 22 FSR	BR7HS	Q211
W 22 FSR-U	BR7HS	Q211
W 22 M	BM7A	
W 22 MP-U	BPM7A	Q305
W 22 MPUS	BPM7A	Q305
W 22 M-U	BM7A	
W 22 MUS	BM7A	
W 22 S	B7S	
W 24	B8S	
W 24 EMRC	BR8ECM	
W 24 EP	BP8ES	
W 24 E-P 11	BP8ES	
W 24 EPR	BPR8ES	Q213
W 24 EPRZ-U	BPR8EIX	
W 24 ES	B8ES	Q201
W 24 ESG-U	BR8EIX	
W 24 ESR	BR8ES	Q207
W 24 ESRV	BR8EG	
W 24 ESRZ-U	BR8EIX	
W 24 ES-U 11	B8ES	Q201
W 24 ESV	B8EG	
W 24 FP	BP8HS	
W 24 FPL	BPR8HSA	
W 24 FPR	BPR8HS	
W 24 FPRL	BPR8HSA	
W 24 FPR-U 10	BPR8HS-10	
W 24 FP-U	BP8HS	
W 24 FRL	BR8HSA	
W 24 FS	B8HS	Q205
W 24 FSG-U	BR8HIX	
W 24 FSR	BR8HS	Q212
W 24 FSR-U 10	BR8HS-10	
W 24 FS-U	B8HS	Q205
W 24 FS-U 10	B8HS-10	
W 24 FSZ-U	BR8HIX	
W 24 S	B8S	
W 24 S-U	B8S	
W 25 EA	BR8EM	
W 25 EAR	BR8EM	
W 25 EB	BR8ET	
W 25 EDR	BR8EQ	
W 25 EDR 14	BR8EQ-14	
W 25 EN	B8EG	
W 25 EPT	BR8EIX	
W 25 FC	B8HCS	
W 25 FN	BR8HIX	
W 27 EDR	BR9EQ-14	

DENSO	→ NGK	Quick
W 27 EDR 14	BR9EQ-14	
W 27 EMRC	BR9ECM	
W 27 EMRZ-U	BR9ECMIX	
W 27 EN	B9EG	
W 27 EPT	BR9EIX	
W 27 ES	B9ES	Q202
W 27 ESC	B9ECS	
W 27 ESG-U	BR9EIX	
W 27 ESR	BR9ES	Q208
W 27 ESR-U	BR9ES	Q208
W 27 ESRV	BR9EG	
W 27 ESRZ-U	BR9EIX	
W 27 ES-U	B9ES	Q202
W 27 ESV	B9EG	
W 27 FC	B9HCS	
W 27 FN	BR9HIX	
W 27 FS	B9HS	
W 27 FSG-U	BR9HIX	
W 27 FSR	BR9HS	
W 27 FSR-U 10	BR9HS-10	
W 27 FS-U	B9HS	
W 27 FS-U 10	B9HS-10	
W 27 FSZ-U	BR9HIX	
W 29 ESG-U	BR10EIX	
W 29 ESRV	BR10EG	
W 29 ESV	B10EG	
W 31 EMRC	BR10ECM	
W 31 EMRZ-U	BR10ECMIX	
W 31 EN	B10EG	
W 31 EPT	R7376-10	
W 31 ES	B10ES	
W 31 ESG-U	BR10EIX	
W 31 ESR-U	BR10ES	
W 31 ESRZ-U	BR10EIX	
W 31 ES-U	B10ES	
W 31 ESZ-U	BR10EIX	
W 31 FS	B10HS	
W 31 FSG-U	BR10HIX	
W 31 FSZ-U	BR10HIX	
W 34 EN	B11EG	
W 34 ESZ-U	BR10EIX	
WA 20 M	BM6F	
WA 20 M-U	BM6F	
WA 22 M	BM7F	
WA 22 M-U	BM7F	
X 16 EPR-U 9	DPR5EA-9	
X 16 EP-U 9	DPR5EA-9	
X 16 FSR-U	DR5HS	
X 16 FS-U	D5HS	
X 20 EPR-U 9	DPR6EA-9	
X 20 EP-U 9	DP6EA-9	
X 20 ES-U	D6EA	

DENSO	→ NGK	Quick
X 20 FSR-U	DR6HS	
X 20 FS-U	D6HA	
X 22 EPRGL	PJR7A	
X 22 EPR-U 9	DPR7EA-9	Q220
X 22 EPRZ-U 9	DPR7EIX-9	
X 22 EP-U	DP7EA-9	
X 22 EP-U 9	DP7EA-9	
X 22 EPZ-U 9	DPR7EIX-9	
X 22 ESG-U	DR7EIX	
X 22 ESR-U	DR7ES	
X 22 ES-U	D7EA	
X 22 ESZ-U	DR7EIX	
X 22 GPR-U	DPR7Z	
X 22 GP-U	DPR7Z	
X 24 EPR-U 9	DPR7EA-9	Q220
X 24 EP-U	DP8EA-9	
X 24 EPZ-U 9	DPR8EIX-9	
X 24 ESG-U	DR8EIX	
X 24 ESR-U	DR8ES-L	Q218
X 24 ESRZ-U 9	DR8EIX	
X 24 ES-U	D8EA	Q216
X 24 ESZ-U	DR8EIX	
X 24 ESZ-U 9	DR8EIX	
X 24 FSR-U	DR8HS	
X 24 FS-U	D8HA	
X 24 GPR-U	DPR8Z	
X 24 GP-U	DP8Z	
X 27 EPR-U 9	DPR7EA-9	Q220
X 27 EPRZ-U 9	DPR9EIX-9	
X 27 EP-U 9	DP9EA-9	
X 27 EPZ-U 9	DPR9EIX-9	
X 27 ESR-U	DR8ES	Q217
X 27 ESRZ-U 9	DR9EIX	
X 27 ES-U	D9EA	
X 27 ESZ-U	DR9EIX	
X 27 ESZ-U 9	DR9EIX	
X 27 ET	J9A	
X 27 ETR	JR9B	Q224
X 27 GPR-U	DPR9Z	
X 29 ESZ-U	DR9EIX	
X 31 ES-U	D10EA	
X 31 ETR	JR10B	
XU 20 EPR-U	DCPR6E	
XU 20 EP-U	DCP6E	
XU 22 EPR	DCPR7E	
XU 22 EPRP	DCPR7EIX	
XU 22 EP-U	DCP7E	
XU 22 HDR 9	LKR7B-9	
XU 22 PR 9	DCPR7EA-9	
XU 24 EPRP	DCPR8EIX	
XU 24 EPRZ-U	DCPR8EIX	
XU 24 EP-U	DCPR8E	



DENSO	→ NGK	Quick
XU 24 EPZ-U	DCPR8EIX	
Y 24 FERC	ER8EH	
Y 27 FER	ER9EH	
Y 27 FERC	ER9EH	
Y 31 FERC	ER10EH	
Z 20 ES-U	D6EA	
ZC 20 HPR 11	ILKAR7L11	
ZXU 20 PR 11	IKR6G11	
ZXU 22 PR 11	IKR6G11	

EVINRUDE	→ NGK	Quick
204 470 091	BR7ES	
278 000 608	BR7ES	
278 000 609	BR8ES	Q207
MCBR 8 EG	BR8EG	
MCBR 8 HS	BR8HS	Q212
MCBR 9 EG	BR9EG	
MCBR 9 ES	BR9ES	Q208
MCBR 10 EG	BR10EG	

EYQUEM	→ NGK	Quick
30 AM	B-4L	
50 AM	B-6L	
50 M	B5HS	
70 M	B6HS	Q203
75 LM	B6ES	
75 M	B6HS	Q203
100 M	B8HS	Q205
200	B-4H	
202 CT	B2-LM	
300 AM	B-4L	
400 J	BR5FS	
406	BP6HS	
450 JS	BPR4FS-15	
450 L	B5ES	
480 CS	BP5S	
500 AM	B-6L	
500 C	B6S	Q302
500 CJT	BM6F	
500 CM	B6S	Q302
500 CS	BP5S	
500 CT	BM6A	Q303
500 J	BR6FS	
500 JS	BPR4FS	
500 M	B5HS	
502 CT	B4-LM	Q301
505 JS	BP5FS	
520 CS	BP5S	
550 CS	BP5S	
550 JS	BPR5FS	
550 LS	BP5ES	

EYQUEM	→ NGK	Quick
550 S	BP4HS	
580 LS	BP5ES	
580 S	BP4HS	
600 CS	BP5S	
600 JS	BPR6FS	
600 L	B6ES	
600 LS	BP6ES	
600 S	BP5HS	
700	B6HS	Q203
700 CM	B6S	Q302
700 CTS	BPM6A	Q304
705 JS	BP7FS	
705 L	B6ES	
705 S	BP6HS	
707 LS	BP6ES	
750	BP6HS	
750 L	B6ES	
750 LJS	BP6EFS	
750 LS	BP6ES	
753 LJS	BP6EFS	
755	B6HS	Q203
755 CJT	BM7F	
755 CM	B6S	Q302
755 CT	BM7A	
755 L	B6ES	
755 LJS	BP6EFS	
755 LS	BP6ES	
755 M	B6HS	Q203
755 S	BP6HS	
775 SX	BP6HS	
775 X	B6HS	Q203
800 L	B6ES	
800 LJS	BP6EFS	
800 LS	BP6ES	
802 L	B6ES	
803 LJS	BP6EFS	
805 L	B6ES	
805 LJS	BP7EFS	
805 LJSP	TR7IX	
805 LP	BR8EIX	
850	B7HS	Q204
850 LS	BP7ES	Q206
883 LJP	B8EFS	
1000	B8HS	Q205
1000 CM	B7S	
1000 L	B8ES	Q201
1000 M	B8HS	Q205
1100	B9HS	
1100 L	B8ES	Q201
1150 L	B9ES	Q202
C 32	B5HS	
C 32 LS	BP5ES	



EYQUEM	→ NGK	Quick
C 32 S	BP5HS	
C 42 LJS 3	BP6EFS	
C 42 S	BP6HS	
C 52 LS	BP5ES	
C 62	B7HS	Q204
C 62 LJS	BP6EFS	
C 62 LS	BP6ES	
C 62 LS 3 X	BP5ET	
C 62 S	BP7HS	
C 72 LJS	BP7EFS	
C 72 LS	BP7ES	Q206
C 72 LS 3 X	BUR6ET	
C 82 LJS	BP7EFS	
C 82 LS	BP7ES	Q206
C 82 LS 3 X	BP7ET	
C 92 LS	BP8ES	
D 775	D6HA	
D 800 L	D7EA	
D 900 L	D8EA	Q216
D 1000	D8HA	
D 1000 L	D9EA	
D 1050 L	D9EA	
FC 42 LS	BCP5ES	
FC 52 LS	BCP5ES	
FC 58 LS	BCP6ES	
FC 62 LS	BCP6ES	
FC 62 LS 2	BCP6ES	
FC 62 LS 3	BCP6ET	
FC 62 LS 3 X	BCP6ET	
FC 72 LS	BCP7ES	
FC 82 LS	BCPR7E	
FC 82 LS 1	BCP7ES	
FC 82 LS 2	BCP7ES	
FN 52 LS	BK5ESZ	
K 200 M	AB-6	
K 300 JS	AP5FS	
K 300 M	AB-6	
K 350 JS	AP5FS	
K 450 JS	AP5FS	
K 500 M	AB-6	
K 550 JS	AP6FS	
K 600 M	AB-6	
K 750 M	AB-7	
KC 62 JS	AP6FS	
R 850	BR7HS	Q211
R 1000	BR8HS	Q212
R 1000 L	BR8ES	Q207
RC 32 LS 5	BPR4ES-11	
RC 42 S	BPR6HS	
RC 42 S	BPR6HS	Q214
RC 42 S	BPR6HS	
RC 52 LS	BPR5EY	

EYQUEM	→ NGK	Quick
RC 52 LS 5	BPR5EY-11	
RC 52 LZ 3 EX	BUR5ET	
RC 52 LZE	ZGR5A	
RC 58 LZ 3 EX	BUR6ET	
RC 62 HJSDP	PTR5A-13	
RC 62 LJS	BPR6EFS	
RC 62 LS	BPR6ES	
RC 62 LS 5	BPR6ES-11	
RC 62 S	BPR7HS	Q215
RC 82 LS	BPR7ES	
RC 82 LS 5	BPR7EY-11	
RFC 42 LS	BKR5ES	
RFC 42 LS 2 E	BKR5EK	
RFC 42 LZ 2 E	BKR6EK	
RFC 50 LZ 2 E	BKR5EK	
RFC 52 LS	BKR5ES	
RFC 52 LS 3	BKR6ETUC	
RFC 52 LS 5	BKR5ES-11	
RFC 52 LSP	BKR6EK	
RFC 52 LZ 3 EX	BKUR5ET	
RFC 52 LZE	ZFR5F	
RFC 52 LZK	BKR5EZ	
RFC 57 LS 3	BCPR6ET	
RFC 58 LS	BKR6ES	
RFC 58 LS 2 E	BKR6EK	
RFC 58 LS 3	BCPR6ET	
RFC 58 LS 5	BKR6ES-11	
RFC 58 LSP	BKR6EZ	
RFC 58 LZ	BKR6EY	
RFC 58 LZ 2	BKR6EKC	
RFC 58 LZ 2 E	BKR6EK	
RFC 58 LZ 3 EX	BKUR6ET	
RFC 58 LZ 5	BKR6EY-11	
RFC 58 LZDP	PFR6G-9	
RFC 58 LZE 5	ZFR6F-11	
RFC 62 LS 3	BKR6ES-11	
RFC 62 LS 3 X	BCPR6ET	
RFC 62 LS 5	BKR6ES-11	
RFC 62 LZ 3 X	BKUR7ET	
RFC 82 LS	BCPR7ES	
RFC 82 LS 5	BCPR7ES-11	
RFCLZ 3 X	BKUR7ET	
RFN 52 HZ	LFR5B	
RFN 52 HZ	LFR5B	
RFN 52 HZ 3 A	LFR5B	
RFN 52 HZ 3 A	LFR5B	
RFN 58 HZ	LFR6B	
RFN 58 HZ	LFR6B	
RFN 58 LZ	BKR6EK	
T 850	C7HSA	
XKC 62 JS	APR6FS	



FORD	→ NGK	Quick
1032 705	BKR5EKUP	
1077 002	PTR5A-13	
1120 170	PZFR5D-11	
1202 935	PLTR6A-10G	
1204 572	PTR6F-13	
1219 309	TR5B-13	
1255 464	TR5B-13	
1307 093	PTR6D-13G	
1315 691	ITR6F13	
1362 012	TR5B-13	
1369 704	TR6AP-13	
1379 739	ILTR5A-13G	
1493 001	TR5B-13	
1505 812	PLFR6A	
1542 499	ZKR7A-10	
1685 720	ILZTR6A8G	
1770 305	SILZNR8C7H	
1787 829	TR5B-13	
1835 546	LZNR7AI-8G	
3539 125	PTR5D-10	
4331 810	PTR5D-13	
5100 429	ILTR6G8G	
1802 090	ILZNR8A7G	
95VW-12405-DA	BKR5EKUP	
XS4F-12405-DA	PTR5A-13	
YM21-12405-AA	PZFR5D-11	
1M5O-12405-CA	PLTR6A-10G	
1S7J-12405-DA	PTR6F-13	
YN2F-12405-A2A	TR5B-13	
YN2J-12405-AA	TR5B-13	
1S7J-12405-EB	PTR6D-13G	
3S4J-12405-AB	ITR6F13	
4M5G-12405-XC	TR5B-13	
5M5G-12405-AA	TR6AP-13	
6M8G-12405-BB	ILTR5A-13G	
4M5G-12405-XE	TR5B-13	
6M5J-12405-AA	PLFR6A	
9S51-12405-AA	ZKR7A-10	
BM5G-12405-CA	ILZTR6A8G	
CM5G-12405-CE	SILZNR8C7H	
4M5G-12405-AA	TR5B-13	
CA6G-12405-AB	LZNR7AI-8G	
3539 125	PTR5D-10	
F43E-12405-EB	PTR5D-13	
9A6G-12405-AA	ILTR6G8G	
DS7G-12405-BA	ILZNR8A7G	
1S7J-18344-EB	PTR6D-13G	
3S4J-18344-AB	ITR6F13	
5M5G-18344-AA	TR6AP-13	
6118-61240-5BB	ILTR5A-13G	
9A6G-12405-BA	ILTR6H8G	
9A6G-12405-CA	ILTR6H8G	

FORD	→ NGK	Quick
AYFS-092FE-C	PLTR6A-10G	
BL3E-12405-CA	LTR6AI-9	
CB5E-12405-AA	LTR6DI-8	
CM5E-12405-BA	LTR6BI-9	
CV6E-12405-AA	ILTR5K13	
HONDA	→ NGK	Quick
1 633 098	R0409B-10	
30717002 / 0	DR9EA	Q219
12260-RL6-G010	ILZKR7B11GS	
12290-59B003	ILZKAR8H8S	
12290-5B0Y01	ILKAR7K11S	
12290-5R0003	DILZKAR7C11S	
12290-P5M-A000	PZFR6F-11	
12290-P73-J001	PFR7G-11	
12290-PCX-0000	PFR7G-11S	
12290-PCX-9999-TA	PFR7G-11S	
12290-PCX-J000	PFR7G-11S	
12290-PFD-J000	IFR6C	
12290-PGE-A01	PZFR6F-11	
12290-PNA-0030	IZFR6K13	
12290-PND-A01	IZFR6K11	
12290-PND-A010-M1	IZFR6K11	
12290-PNE-003	ZFR6K-11	
12290-PRB-A01	IFR7G-11KS	
12290-R1A-H01	SILZKR7C11S	
12290-R1A-H011-M1	SILZKR7C11S	
12290-R2C-T01	SILZKR7C11DS	
12290-R60-U01	IZFR6K11NS	
12290-RB0-J010-M1	DIFR6A13G	
12290-RB0-J11	DIFR6D13	
12290-RB0-JB11	DIFR6D13	
12290-RB1-003	IZFR6K13	
12290-RB1-0031	IZFR6K13	
12290-RL6-G01	ILZKR7B11GS	
12290-RL6-G010-M1	ILZKR7B11GS	
12290-RMX-003	ILFR6J-11K	
12290-RMX-013	ILFR6J-11K	
12290-RSH-003	IFR6G-11K	
12290-RW0-003	DILFR6J11	
12290-RWO-003	DILFR6J11	
31901-NN2-0030	BR6ES	
31901-NX4-7020-M1	R7376-10	
31901-NX4-9010	R7376-10	
31908-KRN-A41	R0451B-8	
31908-KRN-A410-M1	R0451B-8	
31908-KTW-901	LMAR8A-9	
31908-KTW-9010-M1	LMAR8A-9	
31908-KTW-9011-M1	LMAR8A-9	
31908-MGC-003	LMAR8A-9S	
31908-MGC-0031	LMAR8A-9S	



HONDA	→ NGK	Quick
31908-MGC-A0000	LMAR8A-9S	
31908-ZZ3-003	LMAR6C-9	
31908-ZZ3-A0031	LMAR6C-9	
31909-MEN-A31	SILMAR9A9S	
31909-MEN-A310-M1	SILMAR9A9S	
31909-MGC-0031	LMAR8A-9S	
31909-MJPG51	SILMAR8A9S	
31910-MEE-R110-M1	R0409B-10	
31910-MEE-R111-M1	R0409B-10	
31910-MEN-A31	SILMAR10A9S	
31911-HW1-671	IMR9D-9H	
31911-HW1-6710-M1	IMR9D-9H	
31911-KRN-731	R0409B-8	
31911-KRN-7310-M1	R0409B-8	
31911-KSK-731	BR9EG-N-8	
31911-KSK-7310-M1	BR9EG-N-8	
31911-MBT-F21	IJR8B9	
31911-MBT-F210-M1	IJR8B9	
31911-MBW-E11	IMR8C-9H	
31911-MBW-E111-M1	IMR8C-9H	
31911-MBW-E112-M1	IMR8C-9H	
31911-MEE-J01	IMR8C-9HES	
31911-MEE-J010-M1	IMR8C-9HES	
31911-MEE-J011-M1	IMR8C-9HES	
31912-KRN-731	R0409B-9	
31912-MBW-E11	IMR9C-9H	
31912-MBW-E110	IMR9C-9H	
31912-MBW-E111-M1	IMR9C-9H	
31912-MBW-E112-M1	IMR9C-9H	
31912-MCW-003	IMR9B-9H	
31912-MEE-0000	IMR9C-9H	
31912-MEE-J01	IMR8C-9HES	
31912-MEL-003	IMR9C-9HES	
31912-MEL-A	IMR9C-9HES	
31912-MFL-003	IMR9E-9HES	
31912-MGH-641	IMR8E-9HES	
31914-ZOH-003	CMR4H	
31914-ZOH-0031	CMR4H	
31914-Z8Y-003	LR4C-E	
31914-Z8Y-A0030	LR4C-E	
31914-ZOH-003	CMR4H	
31915-ZOH-003	CMR5H	
31915-ZOH-0031	CMR5H	
31916-KPH-901	CPR6EA-9	
31916-KPH-9010-M1	CPR6EA-9	
31916-KRM-841	CPR8EA-9	
31916-KRM-8410-M1	CPR8EA-9	
31916-KRM-8413-M1	CPR8EA-9	
31916-KWB-601	CPR6EA-9S	
31916-MEH-003	SIMR8A9	
31916-ZOH-003	CMR6H	
31916-ZOH-003	CMR6H	

HONDA	→ NGK	Quick
31916-ZY3-003	IZFR6F11	
31916-ZY3-0032	IZFR6F11	
31916-ZY3-004	IZFR6F11	
31917-K40F01	SILMAR8C9	
31917-KPH-901	CPR7EA-9	
31918-MEB-671	IFR8H11	
31918-MEB-6710-M1	IFR8H11	
31918-MEB-672	IFR9H11	
31919-MEB-671	IFR9H11	
31919-MEB-6710-M1	IFR9H11	
31919-MEB-672	IFR8H11	
31916-ZX2-003	ZFR6K-11E	
3191W-Z0M-5400	BPR4ES	
3191W-Z0M-5500	BPR5ES	
3191W-Z0M-5600	BPR6ES	
31921-MBW-E12	IMR8C-9H	
31922-MBW-E12	IMR9C-9H	
31922-MEL-003	IMR9C-9HES	
31922-MFL-003	IMR9E-9HES	
31922-MOW-004	IMR9B-9H	
31926-KRM-841	CPR9EA-9	
31940-NX5-7520-M1	R7282-105	
31940-NX5-9410	R7282-105	
31988-GEV-761	ER8EH-N	
31988-GEV-7611-M1	ER8EH-N	
31989-GEV-761	ER9EH-N	
31999-KW6-6500	B9ECS	
89819-99010	BPR5ES	
89839-99010	BPR6ES	
94701-00408	CR9EIA-9	
98049-58716	ER8EH	
98049-59716	ER9EH	
98049-59726	ER9EH	
98049-60716	ER10EH	
98052-56471	CM-6	
98056-54718	CR4HSA	
98056-54750	C4HSB	
98056-54757	CR4HSB	
98056-54770	C4HSB	
98056-54777	CR4HSB	
98056-55713	C5HSA	
98056-55718	CR5HSA	
98056-55726	CR5HSA	
98056-55750	C5HSB	
98056-55757	CR5HSB	
98056-55770	C5HSB	
98056-55777	CR5HSB	
98056-56713	C6HSA	
98056-56713-00	C6HSA	
98056-56713-01	C6HSA	
98056-56716	CR6HS	Q223
98056-56717	C6HA	



HONDA	→ NGK	Quick
98056-56717-00	CR6HSA	
98056-56718	CR6HSA	
98056-5671R-00	CR6HSA	
98056-56723	C6HSA	
98056-56726	CR6HSA	
98056-57713	C7HSA	
98056-57713-00	C7HSA	
98056-57713-0A	C7HSA	
98056-57716	CR7HS	
98056-57718	CR7HSA	
98056-5771R-00	CR7HSA	
98056-57726	CR7HSA	
98056-57918	CR7HSA-9	
98056-58713	C8HSA	
98056-58716	CR8HS	
98056-58717	C8HA	
98056-58718	CR8HSA	
98059-55916	CR5EH-9	
98059-56916	CR6EH-9	
98059-57817-00	CR7E	Q225
98059-57910	CR7EH-9	
98059-57916	CR7EH-9	
98059-57916-00	CR7E	Q225
98059-57926	CR7EH-9	
98059-58816	CR8E	Q226
98059-58816-H0	CR8E	Q226
98059-58817-00	CR8E	Q226
98059-58910	C8EH-9	
98059-58916	CR8EH-9	Q228
98059-58916-00	CR8E	Q226
98059-5891F	CR8EHIX-9	
98059-58920	C8EH-9	
98059-58926	CR8EH-9	Q228
98059-5892D	IMR8C-9H	
98059-589J6	CR8EH-9S	
98059-589K6	CR8EH-9S	
98059-59816	CR9E	Q227
98059-59816-H0	CR9E	Q227
98059-59910	C9EH-9	
98059-59916	CR9EH-9	Q229
98059-5991F	CR9EHIX-9	
98059-5991U	IMR9A-9H	
98059-5992U	IMR9C-9H	
98059-599U	CR9EHI-9	
98061-57611	DPR7Z	
98061-57616	DPR7Z	
98061-58611	DP8Z	
98061-58616	DPR8Z	
98061-59616	DPR9Z	
98066-54710	DR4HS	
98066-54716	DR4HS	
98066-55710	D5HS	

HONDA	→ NGK	Quick
98066-55716	DR5HS	
98066-55740	D5HS	
98066-56710	D6HA	
98066-56716	DR6HS	
98066-56717	D6HA	
98066-56726	DR6HS	
98066-58710	D8HA	
98066-58714	D8HA	
98066-58716	DR8HS	
98066-58717	D8HA	
98069-38716	DR8ES-L	Q218
98069-38719	DR8ES-L	Q218
98069-55911	DPR5EA-9	
98069-55916	DPR5EA-9	
98069-56717	D6EA	
98069-56911	DP6EA-9	
98069-56916	DPR6EA-9	
98069-5691U	IJR6A9	
98069-5697Q	DCPR6E	
98069-5697Q-HE	DCPR6EIX	
98069-57716	DR7ES	
98069-57717	D7EA	
98069-57717-00	D7EA	
98069-57717-02	D7EA	
98069-57719	DR7ES	
98069-5771P	DR7EA	
98069-5771P-00	DR7EA	
98069-5771R	DR8EA	
98069-57726	DR7EA	
98069-5777P	DR7EB	
98069-57911	DP7EA-9	
98069-57912	DPR7EIX-9	
98069-57916	DPR7EA-9	Q220
98069-57916-00	DPR7EA-9	Q220
98069-5791U	IJR7A9	
98069-57922	DPR7EIX-9	
98069-5792U	IJR7A9	
98069-5797Q	DCPR7E	
98069-58716	DR8ES	Q217
98069-58717	D8EA	Q216
98069-58717-01	D8EA	Q216
98069-58719	DR8ES	Q217
98069-5871P	DR8EA	
98069-5871P-00	DR8EA	
98069-58726	DR8EA	
98069-58911	DP8EA-9	
98069-58912	DPR8EIX-9	
98069-58916	DPR8EA-9	Q221
98069-58916-03	DPR8EA-9	Q221
98069-5891F	DPR8EIX-9	
98069-58922	DPR8EIX-9	
98069-58926	DPR7EA-9	Q220



HONDA	→ NGK	Quick
98069-59717	D9EA	
98069-59911	DP9EA-9	
98069-59912	DPR9EIX-9	
98069-59916	DPR9EA-9	Q222
98069-5991F	DPR9EIX-9	
98069-59926	DPR7EA-9	Q220
98069-60717	D10EA	
98073-52710	B-2	
98073-54710	B-4	
98073-54740	BM4A	
98073-54744	BMR4A	Q306
98073-54750	BM4A	
98073-54754	BMR4A	Q306
98073-54776	BPMR4A	
98073-54944	BPMR4A-10	
98073-56740	BM6A	Q303
98073-56741	BPM6A	Q304
98073-56744	BMR6A	Q307
98073-56750	BM6A	Q303
98073-56941	BPM6A-10	
98073-56944	BPMR6A-10	
98076-52711	BP2HS	
98076-52716	BPR2HS	
98076-52717	BPR2HS	
98076-52719	BP2HS	
98076-54710	B-4H	
98076-54711	BP4HS	
98076-54713	BPR4HSA	
98076-54715	BPR4HSA	
98076-54716	BR4HS	
98076-54716-00	BR4HS	
98076-54717	BPR4HS	
98076-54719	BP4HS	
98076-5471G	BR4HSA	
98076-54720	BR4HS	
98076-54746	BR4HS	
98076-54747	BPR4HS	
98076-54770	B-4H	
98076-54780	B-4H	
98076-54821-CDI	BR4HS	
98076-54911	BP4HS-10	
98076-54911-CDI	BR4HS	
98076-54914	BPR4HS-10	
98076-54917	BPR4HS-10	
98076-54919	BP4HS-10	
98076-5491G	BPR4HSA	
98076-54921	BP4HS-10	
98076-54921-CDI	BR4HS	
98076-54944	BPR4HS-10	
98076-54947	BPR4HS-10	
98076-55711	BP5HS	
98076-55716	BR5HS	

HONDA	→ NGK	Quick
98076-55717	BPR5HS	
98076-55719	BP5HS	
98076-55747	BPR5HS	
98076-56710	B6HS	Q203
98076-56711	B6HS	Q203
98076-56711-00	BP6HSA	
98076-56713	BP6HSA	
98076-56715	BPR6HSA	
98076-56716	BR6HS	Q209
98076-56717	BPR6HS	
98076-56717	BPR6HS	Q214
98076-56717	BPR6HS	
98076-56719	BP6HS	
98076-56719-02	BP6HS	
98076-5671G	BR6HSA	Q210
98076-5671G-00	BR6HSA	Q210
98076-5671M	B6HSA	
98076-56721	BP6HS	
98076-56725	BPR6HSA	
98076-56729	BPR6HS	
98076-56729	BPR6HS	Q214
98076-56729	BPR6HS	
98076-5672G	BR6HSA	Q210
98076-56740	B6HS	Q203
98076-56741	B6HS	Q203
98076-56747	BPR6HS	
98076-56747	BPR6HS	Q214
98076-56747	BPR6HS	
98076-56756	BPR6HS	
98076-56756	BPR6HS	Q214
98076-56756	BPR6HS	
98076-56917	BPR6HS-10	
98076-56927	BPR6HS-10	
98076-57710	B7HS	Q204
98076-57711	BP7HS	
98076-57716	BR7HS	Q211
98076-57717	BPR7HS	Q215
98076-57719	BP7HS	
98076-57719-01	BP7HS	
98076-57740	B7HS	Q204
98076-58710	B8HS	Q205
98076-58711	BP8HS	
98076-58713	BPR8HSA	
98076-58715	BPR8HSA	
98076-58716	BR8HS	Q212
98076-58717	BPR8HS	
98076-58719	BP8HS	
98076-5871G	BR8HSA	
98076-5871G-00	BR8HSA	
98076-5871G-01	BR8HSA	
98076-5872G	BR8HSA	
98076-58740	B8HS	Q205



HONDA	→ NGK	Quick
98076-58747	BPR8HS	
98076-59710	B9HS	
98076-59716	BR9HS	
98076-59740	B9HS	
98078-561BW	IZFR6K-11S	
98078-561CW	IZFR6K-11S	
98079-52876	BPR2ES	
98079-54148	BCPR4ES-11	
98079-5414G	ZFR4F-11	
98079-54173	BUR4EB-11	
98079-54817	BPR4ES	
98079-54841	BP4ES	
98079-54846	BPR4ES	
98079-55132	BPR5EY-11	
98079-55140	BCPR5EY-11	
98079-55141	BP5EY-11	
98079-55144	BP5ES-11	
98079-55145	BPR5ES-11	
98079-55146	BPR5EY-11	
98079-55147	BCPR5ES-11	
98079-55148	BCPR5E-11	
98079-55149	BCPR5EY-11	
98079-5514B	BCPR5E-11	
98079-5514E	BKR5E-11	
98079-5514E-H0	BKR5E-11	
98079-5514F	BCPR5EIX-11	
98079-5514G	ZFR5F-11	
98079-5514G-01	ZFR5F-11	
98079-5514H	PFR5G-11	
98079-5514J	BKR5E-N-11	
98079-5514N	PZFR5F-11	
98079-5514N-01	PZFR5F-11	
98079-5514P	ZFR5J-11	
98079-5514P-H0	ZFR5J-11	
98079-55155	BPR5E-11	
98079-55158	BCPR5E-11	
98079-5515E	BKR5E-11	
98079-5515G	ZFR6F-11	
98079-5515H	PFR5G-11	
98079-5515J	BKR5E-N-11	
98079-5515N	PZFR5F-11	
98079-5515U	IFR5L11	
98079-55173	BUR5EB-11	
98079-55174	BUR5EB-11	
98079-55176	BUR5EB-11	
98079-55178	BUR5EB-11	
98079-5517S	PFR5L-11	
98079-5517U	IFR5L11	
98079-5517V	IFR5G-11K	
98079-55183	BUR5EB-11	
98079-55810	B5ES	
98079-55811	BP5ES	

HONDA	→ NGK	Quick
98079-55816	BR5ES	
98079-55817	BPR5ES	
98079-55840	B5ES	
98079-55841	BP5ES	
98079-55841-03	BP5ES	
98079-55844	BPR5EIX	
98079-55846	BPR5ES	
98079-55847	BR5ES	
98079-55848	BR5ES	
98079-55849	BR5ES	
98079-55855	BPR5E	
98079-5585C	BKR5E	
98079-5585V	ZGR5A	
98079-55876	BPR5ES	
98079-55876-H0	BPR5ES	
98079-5587G	ZFR5F	
98079-5587V	ZGR5A	
98079-55941	BP5EY	
98079-55946	BPR5EY	
98079-55A4N	PZFR5F-13	
98079-55A5N	PZFR5F-13	
98079-56115	BPR6ES-11	
98079-5611R-00	ZFR6F-11	
98079-56132	BPR6EY-11	
98079-56140	BKR6E-11	
98079-56144	BP6ES-11	
98079-56145	BPR6ES-11	
98079-56146	BPR6EY-11	
98079-56147	BCPR6ES-11	
98079-56148	BCPR6E-11	
98079-56149	BCPR6EY-11	
98079-5614A	BCPR6EY-N-11	
98079-5614B	BKR6E-11	
98079-5614E	BKR6E-11	
98079-5614F	BCPR6EIX-11	
98079-5614G	ZFR6F-11	
98079-5614G-01	ZFR6F-11	
98079-5614H	PFR6G-11	
98079-5614J	BKR6E-N-11	
98079-5614J-01	BKR6E-N-11	
98079-5614N	PZFR6F-11	
98079-5614P	ZFR6J-11	
98079-5614P-00	ZFR6J-11	
98079-56155	BPR6ES-11	
98079-56158	BCPR6EY-11	
98079-5615E	BKR6E-11	
98079-5615F	BCPR6EIX-11	
98079-5615G	ZFR6F-11	
98079-5615H	PFR6G-11	
98079-5615J	BKR6E-N-11	
98079-5615N	PZFR6F-11	
98079-5615U	IFR6L11	



HONDA	→ NGK	Quick
98079-56173	BUR6EB-11	
98079-56174	BUR6EB-11	
98079-56175	BP6EY-11	
98079-56179	BUR6EB-11	
98079-5617S	PFR6L-11	
98079-5617T	PFR6N-11	
98079-5617U	IFR6L11	
98079-5617V	IFR6G-11K	
98079-56183	BUR6EB-11	
98079-56810	B6ES	
98079-56811	BP6ES	
98079-56817	BR6ES	
98079-56832	BPR6EY	
98079-56840	B6ES	
98079-56841	BP6ES	
98079-56844	BPR6EIX	
98079-56846	BPR6ES	
98079-56847	BR6ES	
98079-56849	BR6ES	
98079-56854	BP6ES	
98079-56855	BPR6ES	
98079-5685C	BKR6E	
98079-56871-H0	BP6ES	
98079-56876-H0	BPR6ES	
98079-5687V	BPR6EY	
98079-56941	BP6EY	
98079-56946	BPR6EY	
98079-5695U	IFR6C	
98079-5697U	IFR6C	
98079-569BE	BKR6E-9S	
98079-569CE	BKR6E-9S	
98079-56A7H	PFR6G-13	
98079-56A7S	PFR6L-13	
98079-57144	BP7ES-11	
98079-57145	BPR7ES-11	
98079-57146	BPR7EY-11	
98079-57147	BCPR7ES-11	
98079-57148	BCPR7E-11	
98079-57149	BCPR7EY-11	
98079-5714A	BCPR7EY-N-11	
98079-5714B	BCPR7E-11	
98079-5714E	BKR7E-11	
98079-5714F	BKR7EIX-11	
98079-5714G	ZFR7F-11	
98079-5714H	PFR7G-11	
98079-5714J	BKR7E-N-11	
98079-5714P	ZFR7J-11	
98079-57155-01	BPR7ES-11	
98079-57158	BCPR7E-11	
98079-5715E	BKR7E-11	
98079-5715F	BKR7EIX-11	
98079-5715G	ZFR7F-11	

HONDA	→ NGK	Quick
98079-5715H	PFR7G-11	
98079-5715J	BKR7E-N-11	
98079-5715U	IFR7L11	
98079-5715V	IFR7G-11KS	
98079-57171	BPR7EY-11	
98079-57173	BUR7EB-11	
98079-57174	BUR7EB-11	
98079-57175	BR6EB-L-11	
98079-57176	BR6ES	
98079-57177	BUR7EB-11	
98079-57178	BUR7EB-11	
98079-57179	BPR7EY-11	
98079-5717U	IFR7L11	
98079-5717V	IFR7G-11KS	
98079-57183	BUR7EB-11	
98079-571BH	PFR7G-11S	
98079-571BV	IFR7G-11KS	
98079-571CH	PFR7G-11S	
98079-571CV	IFR7G-11KS	
98079-57614	BR7EIX	
98079-57810	B7ES	
98079-57811	BP7ES	Q206
98079-57811-01	BP7ES	Q206
98079-57816	BR7ES	
98079-57840	B7ES	
98079-57841	BP7ES	Q206
98079-57846	BPR7ES	
98079-57847	BR7ES	
98079-57848	BR7ES	
98079-57849	BR7ES	
98079-57855	BPR7ES	
98079-5785C	BKR7E	
98079-5785G	ZFR7F	
98079-57874	BR7EIX	
98079-57876	BR7ES	
98079-57877	BR7ES	
98079-5787G	ZFR7F	
98079-5787T	PFR7N-D	
98079-57941	BP7EY	
98079-57946	BPR7EIX	
98079-5814E	BKR8E-11	
98079-5815E	BKR8E-11	
98079-5815U	FR8BI-11	
98079-5817U	FR8BI-11	
98079-58644	BR8EIX	
98079-58646	BR8EIX	
98079-58648	B8EG	
98079-58649	BR8EG	
98079-58678	B8EG	
98079-58679	BR8EG	
98079-58810	B8ES	Q201
98079-58810-01	B8ES	Q201

KAWASAKI	→ NGK	Quick
E 92070-0016	BR9ECMIX	
E 92070-0019	CR8E	Q226
E 92070-0020	CPR8EB-9	
E 92070-0022	CPR7EA-9	
E 92070-0029	CPR8EA-9	
E 92070-0036	ILZKAR7B11	
E 92070-0534	B8ES	Q201
E 92070-1002	B7ES	
E 92070-1011	D8EA	Q216
E 92070-1014	BP8ES	
E 92070-1014 B	BP8ES	
E 92070-1019	DR8ES	Q217
E 92070-1021	BR8ES	Q207
E 92070-1024	BP6ES	
E 92070-1025	BPR6ES	
E 92070-1026	BP7ES	Q206
E 92070-1027	BPR7ES	
E 92070-1034	D9EA	
E 92070-1044	BPR8ES	Q213
E 92070-1063	BR9EG	
E 92070-1064	BR8EG	
E 92070-1065	DPR8EA-9	Q221
E 92070-1066	DP8EA-9	
E 92070-1067	DP9EA-9	
E 92070-1068	DPR9EA-9	Q222
E 92070-1107	C7HSA	
E 92070-1109	BR9ES	Q208
E 92070-1113	DR7ES	
E 92070-1114	C6HSA	
E 92070-1114 C	C6HSA	
E 92070-1116	DR8ES-L	Q218
E 92070-1124	DP7EA-9	
E 92070-1125	DPR7EA-9	Q220
E 92070-1131	C8HA	
E 92070-1133	BR10EG	
E 92070-1138	DPR6EA-9	
E 92070-1140 C	BP8ES	
E 92070-1141 C	BP7HS	
E 92070-1142	C9E	
E 92070-1143	CR9E	Q227
E 92070-1145	CR9EK	Q230
E 92070-1152	BP7ES	Q206
E 92070-1152 C	BP7ES	Q206
E 92070-1153	CR6HSA	
E 92070-1154	CR7HSA	
E 92070-1155	CR8HSA	
E 92070-1157	BR9ES	Q208
E 92070-1158	CR8EK	
E 92070-1165	DR7EA	
E 92070-1167	BP5ES	
E 92070-1168	C8E	
E 92070-1168 B	C8E	

KAWASAKI	→ NGK	Quick
E 92070-1169	CR8E	Q226
E 92070-1169 B	CR8E	Q226
E 92070-1173	BR10ES	
E 92070-1189	DR9EA	Q219
E 92070-1199	DR8EA	
E 92070-1202 B	BP7HS	
E 92070-1209	CR7E	Q225
E 92070-1210	B9ES	Q202
E 92070-1218	C8HSA	
E 92070-1221	B10EG	
E 92070-1222	B8EG	
E 92070-1223	B9EG	
E 92070-1224	B9EG	
E 92070-1227	BR9EIX	
E 92070-1228	BR9EIX	
E 92070-1230	BR8EIX	
E 92070-1231	BR8EIX	
E 92070-1241	R6252K-105	
E 92070-1250	DPR5EA-9	
E 92070-1253 C	B9ECS	
E 92070-1254	CR9EKPA	
E 92070-1263	BP8HS	
E 92070-1264	CR9EK	Q230
E 92070-1266	CR9E	Q227
E 92070-1270	BR8EIX	
E 92070-1271	BR9EIX	
E 92070-2051	BM6A	Q303
E 92070-2052	BP4HS	
E 92070-2055	B2-LM	
E 92070-2056	BM4A	
E 92070-2060	BMR6A	Q307
E 92070-2061	BPR4HS	
E 92070-2062	BR6S	
E 92070-2066	BM7A	
E 92070-2070	BR4HS	
E 92070-2072	BMR4A	Q306
E 92070-2074	BMR7A	
E 92070-2077	BPR5ES	
E 92070-2078	BR8ES	Q207
E 92070-2086	B-2H	
E 92070-2090	B-4H	
E 92070-2097	BPR2HS	
E 92070-2098	BR4-LM	
E 92070-2100	BMR2A	
E 92070-2102	BPM7A	Q305
E 92070-2103	BMR2A-10	
E 92070-2106	BPMR4A	
E 92070-2108	BPMR6A	Q308
E 92070-2109	BPM6A	Q304
E 92070-2110	BPR2ES	
E 92070-2112	BPR4ES	
E 92070-2115	BPMR8Y	



MAGNETI MARELLI	→ NGK	Quick
F 6 NC	BP5HS	
T 7 LCR	BPR6EFS	
8 LDCR	PTR5A-13	
CW 6 N	B6HS	Q203
CW 6 NP	BP6HS	
CW 7 LP	BP6ES	
CW 7 LPR	BPR6ES	
CW 7 NP	BP6HS	
8 LPR	BCPR7ES	
AW 5 C	BM6A	Q303
AW 56 C	BM7A	
CM 1 N	AB-2	
CM 2 N	AB-2	
CM 3 N	AB-6	
CM 4 N	AB-6	
CM 5 N	AB-6	
CM 6 N	AB-7	
CU 7 N	C7HSA	
CW 2 C	B-2	
CW 2 CJ	B-2	
CW 2 L	B4ES	
CW 2 N	B-4H	
CW 3 C	B-4	
CW 3 CJ	B-4	
CW 3 CP	BP-4	
CW 3 L	B4ES	
CW 3 N	B-4H	
CW 4 A	B5ES	
CW 4 C	B-4	
CW 4 CJ	B-4	
CW 4 CP	BP-4	
CW 4 L	B4ES	
CW 4 LP	BP4ES	
CW 4 N	B-4H	
CW 4 NJ	B-4H	
CW 5 C	B-4	
CW 5 CP	BP5S	
CW 5 L	B5ES	
CW 5 LJ	B5ES	
CW 5 LP	BP5ES	
CW 5 LS	B5ES	
CW 5 LSZ	B5ES	
CW 5 N	B5HS	
CW 5 NJ	B5HS	
CW 5 NP	BP5HS	
CW 5 NR	BR5HS	
CW 5 NS	B5HS	
CW 5 NSZ	B5HS	
CW 6 C	B6S	Q302
CW 6 CE	BM6A	Q303
CW 6 CJ	B6S	Q302
CW 6 L	B5ES	

MAGNETI MARELLI	→ NGK	Quick
CW 6 LJ	B5ES	
CW 6 LP	BP5ES	
CW 6 LR	BR5ES	
CW 6 LS	B5ES	
CW 6 LSZ	B5ES	
CW 6 NE	BM6A	Q303
CW 6 NJ	B6HS	Q203
CW 6 NPR	BPR6HS	
CW 6 NPR	BPR6HS	Q214
CW 6 NPR	BPR6HS	
CW 6 NR	BR6HS	Q209
CW 7 C	B6S	Q302
CW 7 L	B6ES	
CW 7 LCR	BKR6E	
CW 7 LJ	B6ES	
CW 7 LPH	BP6ES	
CW 7 LR	BR6ES	
CW 7 N	B6HS	Q203
CW 7 NJ	B6HS	Q203
CW 7 NPR	BPR6HS	
CW 7 NPR	BPR6HS	Q214
CW 7 NPR	BPR6HS	
CW 7 NR	BR6HS	Q209
CW 8 CJ	B7S	
CW 8 L	B7ES	
CW 8 LCR	BCPR7ES	
CW 8 LJ	B7ES	
CW 8 LP	BP7ES	Q206
CW 8 LPR	BPR7ES	
CW 8 LPS	BP7ES	Q206
CW 8 N	B7HS	Q204
CW 8 NP	BP7HS	
CW 8 NR	BR7HS	Q211
CW 9 L	B8ES	Q201
CW 9 LJ	B8ES	Q201
CW 9 LP	BP8ES	
CW 9 N	B8HS	Q205
CW 10 L	B8EG	
CW 11 L	B9EG	
CW 12 L	B9EG	
CW 12 NV	BUH	
CW 13 L	B10EG	
CW 14 L	B10EG	
CW 25 N	B-4H	
CW 55 N	B5HS	
CW 67 L	B6ES	
CW 67 LP	BP6ES	
CW 67 N	BP6HS	
CW 67 NJ	B6HS	Q203
CW 67 NR	BR6HS	Q209
CW 67 P	BP5ES	
CW 75 LP	BP6ES	



MAGNETI MARELLI	→ NGK	Quick
CW 78 L	B6ES	
CW 78 LP	BP6ES	
CW 78 LPR	BPR6ES	
CW 78 LPS	BP6ES	
CW 89 LP	BP7ES	Q206
CW 112 L	B9EG	
CW 225 A	B6HS	Q203
CW 250 A	B7HS	Q204
CW 260 N	B7HS	Q204
CWC 6 NJ	B6HS	Q203
CWC 7 NJ	B6HS	Q203
CWC 9 NJ	B7HS	Q204
CWC 12 NJ	B8HS	Q205
CWC 67 NJ	B6HS	Q203
CWF 11 L	BR8EIX	
CWP 5 N	BR6HIX	
CWP 6 N	BR6HIX	
CWP 7 N	BR6HIX	
CWP 8 L	BR7EIX	
CWP 8 N	BR7HIX	
CWP 9 L	BR8EIX	
CWP 9 N	BR8HIX	
CWP 10 L	BR9EIX	
CWP 10 N	BR9HIX	
CWP 11 L	BR10EIX	
CX 6 N	D6HA	
CX 8 L	D8EA	Q216
CX 8 N	D8HA	
DW 4 CJR	BR6S	
F 6 NCR	BPR5HS	
FC 6 N	B5HS	
FC 7 N	B6HS	Q203
FC 9 L	BP8ES	
SW 5 C	BM6F	
T 8 LC	BP7EFS	
TM 2 NP	AP5FS	
TM 4 NP	AP6FS	
TW 4 LP	BP5EFS	
TW 5 NP	BP5FS	
TW 6 NP	BP6FS	
TW 7 LP	BP6EFS	
TW 7 LPR	BPR6EFS	
TW 7 NP	BP6FS	
TW 78 LP	BP6EFS	
TW 78 LPR	BPR6EFS	
TW 78 NPR	BPR6FS	
MARCHAL / VALEO	→ NGK	Quick
11 720	B8HS	Q205
12 086	B8HS	Q205
17 C	AB-7	
19 C	AB-7	

MARCHAL / VALEO	→ NGK	Quick
19 E	AB-7	
19 L	AB-7	
2 / 32 H	B8ES	Q201
2 / 33 H	B7ES	
20 C	AB-6	
20 E	AB-6	
20 L	AB-6	
21 C	AB-6	
21 E	AB-6	
21 L	AB-6	
22 L	AB-2	
22 LM	AB-2	
23 F	A6FS	
32 LM	AB-2	
34 / 5 HS	BP6ES	
34 C	B7S	
34 CM	B7S	
34 HS	B7ES	
34 HSM	B7ES	
34 S	B7HS	Q204
35	B6HS	Q203
35 / 1	BP6HS	
35 / 1 B	BP6HS	
35 / 1 D	BP6HS	
35 / 36 D	B6HS	Q203
35 / 36 P	B6HS	Q203
35 / 36 R	B6HS	Q203
35 B	B6HS	Q203
35 C	B6S	Q302
35 CM	B6S	Q302
35 HA	BP6ES	
35 HS	B6ES	
35 M	B6HS	Q203
35 P	B6HS	Q203
36	B5HS	
36 B	B5HS	
36 C	B-4	
36 CM	B-4	
36 D	B5HS	
36 HS	B5ES	
36 M	B5HS	
36 P	B5HS	
37 S	B5HS	
41 306	AB-8	
4 N	B7HS	Q204
5 H	B7ES	
5 N	BP6HS	
5 NCYCLO	BP6HS	
64 H	BP7ES	Q206
67 HP	BR8EIX	
6 H	BP7ES	Q206
6 N	BP5HS	



MARCHAL / VALEO	→ NGK	Quick
70 H	BP6ES	
76 H	BP5ES	
7 H	BP6ES	
84 H	BP5ES	
88 N	B5HS	
8 H	BP6ES	
9 H	BP5ES	
C 64 H	BP6EFS	
C 68 H	BP6EFS	
C 7 H	BP6EFS	
F 70 H	BCP7ES	
F 74 H	BCP6ES	
F 80 H	BCP7ES	
GT 34	BP7HS	
GT 34 / 2 H	BP6ES	
GT 34 / 5	BP6HS	
GT 34 / 5 D	BP6HS	
GT 34 / 5 H	BP6ES	
GT 34 / 5 HA	BP6ES	
GT 34 / 5 HD	BP6ES	
GT 34 D	BP7HS	
GT 34 H	BP7ES	Q206
GT 34 HD	BP6ES	
GT 35	BP5HS	
GT 35 D	BP5HS	
GT 35 H	BP5ES	
GT 35 HD	BP5ES	
H 32 RG	B9EG	
H 33 RG	B8EG	
H 34 F	B8ES	Q201
HA 32 / 2	B8ES	Q201
HA 32 RS	B9EG	
HF 34	B7ES	
HF 34 F	B8ES	Q201
RR 31 HS	B10EG	
RR 32 HS	BR9EIX	
RR 33 HSS	BR8EIX	
SCGT 34 / 5H	BP6EFS	
SCGT 35 H	BP6EFS	
V 36 A	B5HS	
V 6 NSOLEX	B5HS	
MERCURISER	→ NGK	Quick
33-104	BR7ES	
33-11458 M	B6HS-10	
33-12127	BP6HS-10	
33-123	BR6ES	
33-12343	BP8HS-10	
33-12343 B	BP8HS-10	
33-129	AR6FS	
33-136862	BU8H	

MERCURISER	→ NGK	Quick
33-136862 B	BU8H	
33-14	BP5S	
33-14103550	BUZHW	
33-14103568	BUZ8H	
33-14103570	BUZHW-2	
33-14814548	BPZ8HS-10	
33-14814568	BPZ8HS-15	
33-17719547	BPR7HS-10	
33-18	BPR4FS-11	
33-18 S	BPR4FS-11	
33-19424	BP8HS-15	
33-19796	BPR6HS-10	
33-306	B6HS	Q203
33-312	BP6HS-10	
33-327	BPR6HS	
33-327	BPR6HS	Q214
33-327	BPR6HS	
33-328	BP7HS	
33-400	BR6FS	
33-400 S	BR6FS	
33-401	BP6EFS	
33-406	BPR6FS	
33-41263 B	B7HS-10	
33-41263 M	B7HS-10	
33-592	BR6S	
33-59571	BR6FS	
33-59571 B	BR6FS	
33-63	BP5S	
33-670	R5673-8	
33-802	R5673-7	
33-803507	DCPR6E	
33-807 C	B8HS	Q205
33-807 S	B8HS	Q205
33-809679	BR9ES	Q208
33-809679 B	BR9ES	Q208
33-809680	BR8ES	Q207
33-809680 B	BR8ES	Q207
33-811	B7HS	Q204
33-811 S	B7HS	Q204
33-8134101	UR5	
33-813413	B7S	
33-8134141	BP7HS	
33-813415	B8S	
33-813421	R5673-8	
33-813423	BPR6HS	
33-813423	BPR6HS	Q214
33-813423	BPR6HS	
33-813425	AR6FS	
33-813469	B6S	Q302
33-8134711	BR6ES	
33-814	BPR7HS-10	
33-816336	BPR6EFS	

MERCUISER	→ NGK	Quick
33-8167372	BP8H-N-10	
33-8167372 B	BP8H-N-10	
33-8168372	BPZ8H-N-10	
33-8168372 B	BPZ8H-N-10	
33-818	BR9ES	Q208
33-818 S	BR9ES	Q208
33-821916	BR7HS	Q211
33-821 C	B9HS-10	
33-821 S	B9HS-10	
33-823	B6S	Q302
33-82370 M 1	B6HS	Q203
33-82371 B	B7HS	Q204
33-82371 M	B7HS	Q204
33-82372 M	B8HS	Q205
33-823 S	B6S	Q302
33-824	BUHX	
33-825 C	B7S	
33-825 S	B7S	
33-827858	DPR6EA-9	
33-827859	CR6HS	Q223
33-827 C	BUHW	
33-827 S	BUHW	
33-828 C	BZ7HS-10	
33-828 S	BZ7HS-10	
33-833 C	BUHW-2	
33-833 S	BUHW-2	
33-838	BUZHW-2	
33-841 C	B6S	Q302
33-84409 B	B8HS-10	
33-84409 M	B8HS-10	
33-84675 M	B5HS	
33-8556721	PZFR5F-11	
33-8557171	ZFR5F-11	
33-859495	LFR5A-11	
33-874	BR7HS	Q211
33-876	BUZ8H	
33-880	BR8ES	Q207
33-881284	LFR6A-11	
33-883	BR7HS	Q211
33-885 C	BU8H	
33-885 S	BU8H	
33-886	BUZ8H	
33-896	B5HS	
33-898	BUZHW	
33-918	ZFR6F-11	
33-924	BP8HS-15	
33-936 C	BP8HS-10	
33-936 S	BP8HS-10	
33-938	BPZ8HS-10	
33-939	BPZ8HS-15	
33-941	BR8HS	Q212
33-97180	BUHW	

MERCUISER	→ NGK	Quick
33-97180 B	BUHW	
33-97182	BUHW-2	
33-97182 B	BUHW-2	
33-97184	BP7HS-10	
33-97186	B9HS-10	
33-97186 B	B9HS-10	
33-97389	BPR6FS	
MERCURY	→ NGK	Quick
121 27	BP6HS-10	
123 43	BP8HS-10	
123 43 B	BP8HS-10	
136 86 B2	BU8H	
136 86 Q	BU8H	
141 035 50	BUZHW	
141 035 68	BUZ8H	
141 03 Q	BUZHW-2	
148 145 68	BPZ8HS-15	
148 14 Q	BPZ8HS-10	
177 195 47	BPR7HS-10	
194 24	BP8HS-15	
197 96	BPR6HS-10	
338 432 20	IZFR6J	
338 432 20 Q	IZFR6J	
338 892 46 Q39	ILFR6G-E	
338 895 97 Q	IZFR5G	
338 896 80	ILFR6G	
338 896 80 001	ILFR6G	
412 63 B	B7HS-10	
412 63 M	B7HS-10	
595 71 B	BR6FS	
803 507	DCPR6E	
803 990	TR5IX	
809 679	BR9ES	Q208
809 679 B	BR9ES	Q208
809 680	BR8ES	Q207
809 680 B	BR8ES	Q207
810 883	BPR6ES	
813 413	B7S	
813 414 1	BP7HS	
813 415	B8S	
813 421 4	R5673-8	
813 423	BPR6HS	
813 423	BPR6HS	Q214
813 423	BPR6HS	
813 469	B6S	Q302
813 471 1	BR6ES	
816 336 Q	BPR6EFS	
816 737 B2	BP8H-N-10	
816 737 Q	BP8H-N-10	
816 837 B2	BPZ8H-N-10	



MERCURY	→ NGK	Quick
816 837 Q	BPZ8H-N-10	
821 916	BR7HS	Q211
823 70 M1	B6HS	Q203
823 71 B	B7HS	Q204
823 71 M	B7HS	Q204
823 72 M	B8HS	Q205
824 406 8	BR8HS-10	
824 406 8 B	BR8HS-10	
827 858 Q	DPR6EA-9	
827 859	CR6HS	Q223
828 938	BR7ES	
828 942	BR7HS-10	
828 943	BPR8ES	Q213
828 945	BR8HS	Q212
828 987	B8ES	Q201
843 220 Q	IZFR6J	
843 825	BR9ECS	
846 75 M	B5HS	
852 868 140	DR5HS	
855 717 1	ZFR5F-11	
859 495 Q	LFR5A-11	
881 284 Q	LFR6A-11	
885 185	BPR8EIX	
889 246 Q39	ILFR6G	
889 423	PZFR6H	
889 597 Q	IZFR5G	
892 567 Q	IZFR5J	
896 322	B6HS-10	
898 829 001	LFR4A-E	
8M 000 6613	ILFR6G-E	
8M 000 7910	IZFR7M	
8M 000 7919	IZFR7M	
8M 000 9927	IZFR7M	
971 80 B	BUHW	
971 80 Q	BUHW	
971 82 B	BUHW-2	
971 82 Q	BUHW-2	
971 84	BP7HS-10	
971 86	B9HS-10	
971 86 B	B9HS-10	
973 89	BPR6FS	
MOTORCRAFT	→ NGK	Quick
1 Y 00	BPR5ES	
1 Y 01	BPR6ES	
1 Y 03	BPR5ES-11	
1 Y 06	BKR5E	
1 Y 07	BKR6E	
1 Y 09	BKR5E-11	
1 Y 0 A	BKR6E-11	
1 Y 0 B	BKR7E-11	

MOTORCRAFT	→ NGK	Quick
1 Y 0 F	DCPR7E	
1 Y 0 G	ZFR5F-11	
1 Y 0 H	ZFR6F-11	
1 Y 0 K	BPR5ES-13	
1 Y 0 L	BRE527Y-11	
1 YR 7	BKR6EIX-P	
1 YR 9	BKR5EIX-11P	
1 YRA	BKR6EIX-11P	
1 YRF	DCPR7EIX-P	
1 YRG	ZFR5FIX-11P	
1 YRH	ZFR6FIX-11P	
A 1	B8S	
A 11	B-2	
A 11 NX	BM4A	
A 11 U	B-2	
A 11 X	B-2	
A 1 CU	B8S	
A 1 X	B8S	
A 2	B7S	
A 21 X	B8S	
A 22	BP6S	
A 22 CU	BP6S	
A 22 NX	BPM7A	Q305
A 2 NX	BM7A	
A 2 X	B7S	
A 3	B6S	Q302
A 32	BP6S	
A 3 CU	B6S	Q302
A 3 NX	BM6A	Q303
A 3 X	B6S	Q302
A 4	B6S	Q302
A 42	BP5S	
A 42 CU	BP5S	
A 5	B6S	Q302
A 52	BP5S	
A 52 CU	BP5S	
A 5 CU	B6S	Q302
A 5 X	B6S	Q302
A 7	B-4	
A 7 LM	B4-LM	Q301
A 7 N	BM6A	Q303
A 7 NU	BM6A	Q303
A 7 NX	BM6A	Q303
A 7 U	B-4	
A 7 X	B-4	
A 82	BP-4	
A 9	B-4	
A 901	B8S	
A 9 X	B-4	
AE 1 C	B7HS	Q204
AE 1 X	B7HS	Q204
AE 2	B7HS	Q204



MOTORCRAFT	→ NGK	Quick
AE 22	BP6HS	
AE 22 C	BP6HS	
AE 2 C	B7HS	Q204
AE 2 X	B7HS	Q204
AE 3	B6HS	Q203
AE 32	BP6HS	
AE 32 C	BP6HS	
AE 3 C	B6HS	Q203
AE 3 X	B6HS	Q203
AE 4	B5HS	
AE 42	BP5HS	
AE 4 X	B5HS	
AE 52	BP5HS	
AE 6	B5HS	
AE 62	BP5HS	
AE 7	B-4H	
AE 8	B-4H	
AE 901	B9HS	
AE 901 X	B9HS-10	
AE 92	BP-4H	
AER 32	BPR6HS	
AER 32	BPR6HS	Q214
AER 32	BPR6HS	
AER 4	BR5HS	
AER 4 X	BR5HS	
AF 12	BP7FS	
AF 2	B7FS	
AF 22	BP6FS	
AF 3	BR6FS	
AF 32	BP6FS	
AF 3 NX	BM7F	
AF 42	BP5FS	
AF 52	BP4FS	
AF 5 NX	BM6F	
AG 1	B8ES	Q201
AG 12	BP7ES	Q206
AG 12 C	BP7ES	Q206
AG 12 CU	BP7ES	Q206
AG 1 C	B8ES	Q201
AG 1 X	B8ES	Q201
AG 2	B7ES	
AG 22	BP6ES	
AG 224	BP6ES-11	
AG 22 C	BP6ES	
AG 22 CU	BP6ES	
AG 23	B7ECS	
AG 252	BP6ES	
AG 252 C	BP6ES	
AG 25 C	B7EM	
AG 2 C	B7ES	
AG 2 CU	B7ES	
AG 2 X	B7ES	

MOTORCRAFT	→ NGK	Quick
AG 3	B6ES	
AG 32 A	BP6ES	
AG 32 C	BP6ES	
AG 32 CU	BP6ES	
AG 34 CU	BP6EY	
AG 34 CU 11	BP6EY-11	
AG 3 C	B6ES	
AG 3 X	B6ES	
AG 4	B5ES	
AG 403	R7376-10	
AG 403 C	R7376-10	
AG 42	BP5ES	
AG 42 CU	BP5ES	
AG 44	ZGR5C	
AG 44 CU	BP5EY	
AG 5	B5ES	
AG 501	B10ES	
AG 501 X	BR10EIX	
AG 52	BP5ES	
AG 54	ZGR5C	
AG 54 CU	BP4EY	
AG 5 CU	B5ES	
AG 603	BR9EIX	
AG 603 C	BR9EIX	
AG 7	B5ES	
AG 701	B9ES	Q202
AG 701 C	B9ES	Q202
AG 701 CU	B9ES	Q202
AG 701 X	BR9EIX	
AG 82	BP4ES	
AG 9	B4ES	
AG 901	B9ES	Q202
AG 901 C	B9ES	Q202
AG 901 CU	B9ES	Q202
AG 901 X	BR8EIX	
AG 902	BP8ES	
AG 903	B8EG	
AG 9 U	B4ES	
AGF 12	BP7EFS	
AGF 12 C	BP7EFS	
AGF 22 C	BP6EFS	
AGF 32 CU	BP6EFS	
AGFS 22 C 1	BPR6EFS	
AGFS 22 FE 1	PTR6F-13	
AGFS 22 FE 13 J	PTR6D-13G	
AGFS 22 IPJ	ITR6F13	
AGFS 22 YPC	ITR6F13	
AGFS 32 C 1	BPR6EFS	
AGKO	BUE	
AGN 42	BP5ES	
AGP 12 C	BCP7ES	
AGP 22 C	BCP6ES	



MOTORCRAFT	→ NGK	Quick
AGP 701 C	R7436-10	
AGPR 12 C	BCPR7ES	
AGPR 12 P	BKR7EIX-11	
AGPR 12 PP	PFR7B-11	
AGPR 12 PP 11	PFR7B-11	
AGPR 12 PP 8	PFR7B	
AGPR 22 C	BKR6ES	
AGPR 22 C 1	BKR6ES-11	
AGPR 22 CD	BKR6ES	
AGPR 22 CD 1	BKR6ES-11	
AGPR 22 P	BKR6EIX-11	
AGPR 22 PP	PFR6B-11	
AGPR 22 PPJ	PFR6B-11	
AGPR 32 C	BKR6ES	
AGPR 32 CD 1	BKR6ES-11	
AGPR 32 PD	BKR5EKUP	
AGPR 902 C	BCPR9ES-11	
AGPR 902 P	R7436-9	
AGPS 12 C	BCPR7ES	
AGPS 12 P 1	BKR7EIX-11	
AGPS 22 C	BKR6ES	
AGPS 22 C 1	BKR6ES-11	
AGPS 22 P	BKR6EIX-11	
AGPS 22 P 1	BKR6EIX-11	
AGPS 22 PP 1	PFR6B-11	
AGPS 32 C	BKR6ES	
AGPS 32 C 1	BKR6ES-11	
AGPS 44 F	PZFR5D-11	
AGPS 44 F 11	PZFR5D-11	
AGPS 44 F 11 J	PZFR5D-11	
AGR 12 C	BPR7ES	
AGR 16 C	BR8ET	
AGR 1 X	BR8ES	Q207
AGR 21	BR6ES	
AGR 22	BPR6ES	
AGR 22 C	BPR6ES	
AGR 22 CU	BPR6ES	
AGR 2 C	BR7ES	
AGR 31	BR6ES	
AGR 32	BPR6ES	
AGR 32 C	BPR6ES	
AGR 32 CU	BPR6ES	
AGR 34 CU	BPR6EY	
AGR 3 X	BR6ES	
AGR 41	BR5ES	
AGR 42	BPR5ES	
AGR 42 C	BPR5ES	
AGR 42 CU	BPR5ES	
AGR 44 CU	BPR5EY	
AGR 44 CU 11	BPR5EY-11	
AGR 47 CU 11	ZGR5B-11	
AGR 51	BR5ES	

MOTORCRAFT	→ NGK	Quick
AGR 52	BPR5ES	
AGR 54 CU	BPR5EY	
AGR 701 X	BR9EIX	
AGR 82	BPR4ES	
AGR 901 X	BR8EIX	
AGRF 22	BPR6EFS	
AGRF 226	BPR6EFS-13	
AGRF 22 C	BPR6EFS	
AGRF 22 C 1	BPR6EFS	
AGRF 22 PP 1	PTR5D-10	
AGRF 32	BPR6EFS	
AGRF 326	BPR6EFS-13	
AGRF 32 C 1	BPR6EFS	
AGRF 42	BPR5EFS	
AGRF 52	BPR5EFS	
AGRP 52	ZFR4F-11	
AGS 22 C	BPR6ES	
AGS 32 C	BPR5ES	
AGS 32 C 11	BPR5ES-11	
AGS 42 CC	BPR4ES	
AGSF 22 FM 1	TR5IX	
AGSF 22 FSCM	PTR6D-13G	
AGSF 22 PGM	PTR6F-13	
AGSF 22 PM	PTR6F-13	
AGSF 22 PP	PTR6F-13	
AGSF 22 PPJ	PTR6F-13	
AGSF 22 PPM	PTR6F-13	
AGSF 22 WM	BPR5EFS	
AGSF 22 YPC	ITR6F13	
AGSF 24 C	TR5-1	
AGSF 24 N	TR55-1	
AGSF 32 C	BPR5EFS	
AGSF 32 FEC	PTR5F-11	
AGSF 32 FEM	PTR5D-10	
AGSF 32 FM	PTR5D-13	
AGSF 32 W	TR55IX	
AGSF 32 WM	ITR6F13	
AGSF 32 YPC	TR5AI-13	
AGSF 34 C	TR5-1	
AGSP 32	BKR6ES-11	
AGSP 32 C	BKR6ES-11	
AGSP 32 FP	PFR5G-11	
AGSP 32 PR	PFR6B-11	
AGSP 33 C	ZFR6F-11	
AGSP 52	BKR5ES	
AL 11	B-4L	
AL 5	B-6L	
AL 5 X	B-6L	
AL 7	B-6L	
AL 7 U	B-6L	
AL 7 X	B-6L	
AL 9	B-4L	



MOTORCRAFT	→ NGK	Quick
AL 9 X	B-4L	
AR 21 X	BR6S	
AR 31	BR6S	
AR 32	BP6S	
AR 41	BR6S	
AR 42	BP5S	
AR 51	BR6S	
AR 52	BP5S	
AR 7 N	BMR6A	Q307
AR 82	BP-4	
ARF 2	BR6FS	
ARF 22	BPR6FS	
ARF 22 C	BPR6FS	
ARF 22 CU	BPR6FS	
ARF 26	BR6FS	
ARF 3	BR6FS	
ARF 32	BPR6FS	
ARF 326	BPR6FS	
ARF 32 C 6	BPR6FS	
ARF 32 M	BPR6FS	
ARF 36	BR6FS	
ARF 4	BR5FS	
ARF 41 CU 15	BR5FS	
ARF 42	BPR5FS	
ARF 426	BPR5FS-15	
ARF 42 CU	BPR5FS	
ARF 46	BR5FS	
ARF 52	BPR4FS	
ARF 526	BPR4FS-15	
ARF 6	BR5FS	
ARF 62	BPR4FS	
ARF 626	BPR4FS-15	
ARF 8	BR5FS	
ARF 86	BR5FS	
ASF 32	BPR6FS	
ASF 32 C	BPR6FS	
ASF 32 M	BPR6FS	
ASF 32 P	UR5IX	
ASF 42	BPR5FS-11	
ASF 426 C	BPR5FS-15	
ASF 42 C	BPR5FS-11	
ASF 42 P	UR4IX	
ASF 44 P	UR4IX	
ASF 52	BPR4FS	
ASF 526	BPR4FS-15	
AT 1	B8S	
AT 10	B-2	
AT 2	B7S	
AT 3	B6S	Q302
AT 4	B6S	Q302
AT 42	BP5S	
AT 42 M	BP5S	

MOTORCRAFT	→ NGK	Quick
AT 4 A	B6S	Q302
AT 6	B6S	Q302
AT 8	B-4	
ATL 3	B-6L	
ATL 4	B-6L	
ATL 8	B-4L	
AV 1 X	B8HS	Q205
AV 22 CU	BP6HS	
AV 2 CU	B7HS	Q204
AV 2 X	B7HS	Q204
AV 3 CU	B6HS	Q203
AV 4	B5HS	
AV 42	BP5HS	
AV 52	BP5HS	
AV 6	B-4H	
AV 6 CU	B-4H	
AV 701 CU 10	B9HS-10	
AV 82	BP-4H	
AV 901 CU	B9HS	
AV 901 X 4	B9HS-10	
AVKO	BUH	
AVKOD	BUHW	
AVZKO	BUHX	
AWRF 32	BPR6EFS	
AWRF 325	BPR6EFS-13	
AWRF 42	BPR5EFS	
AWSF 22 C	BPR6EFS	
AWSF 22 E	TR6IX	
AWSF 22 F	PTR6D-13	
AWSF 22 FM	TR5IX	
AWSF 22 FM 1	TR5IX	
AWSF 22 FS	PTR6D-13G	
AWSF 24 C	TR5-1	
AWSF 32	BPR6EFS	
AWSF 32 C	BPR6EFS	
AWSF 32 E	TR55IX	
AWSF 32 EE	TR55IX	
AWSF 32 F	PTR5D-10	
AWSF 32 FM	TR5IX	
AWSF 32 P	TR5IX	
AWSF 32 PM	TR5IX	
AWSF 32 PP	TR5IX	
AWSF 34	TR5-1	
AWSF 34 C	TR5-1	
AWSF 34 PP	TR5-1IX	
AWSF 42	BPR5EFS	
AWSF 42 C	BPR5EFS	
AWSF 42 EE	TR55IX	
AWSF 42 PP	TR55IX	
AWSF 44 C	TR5-1	
AWSF 52 C	BPR5EFS	
AWSF 54	TR5-1	



NISSAN	→ NGK	Quick
22401-02P15	BCPR5E-11	
22401-02P16	BCPR6E-11	
22401-02P17	BCPR7E-11	
22401-03300	B-4	
22401-08U15	PFR5K-11	
22401-08U75	PFR5K-11	
22401-0P615	PFR5F-11A	
22401-0P616	PFR6F-11A	
22401-0P675	PFR5F-11A	
22401-0P676	PFR6F-11A	
22401-10F14	BCPR4ES-11	
22401-10F15	BCP5ES	
22401-10F16	BCP6ES	
22401-10F17	BCP7ES	
22401-10P15	BCPR5E-11	
22401-10P16	BKR6E-11	
22401-10P17	BCPR7E-11	
22401-11200	BC6ES	
22401-12E14	BCPR4ES-11	
22401-12E15	BCPR5ES	
22401-12E16	BCPR6ES	
22401-12E17	BCPR7ES	
22401-12E76	BCPR6ES	
22401-18V15	PGR5A	
22401-18V16	PGR6A	
22401-18V17	PGR7A	
22401-19V15	BCP5ES	
22401-19V16	BCP6ES	
22401-19V17	BCP7ES	
22401-19V65	BCPR5ES	
22401-19V66	BCPR6ES	
22401-1A50A	ILFR5B11	
22401-1F720	BKR5E-11	
22401-1HC1B	LZKAR6AP-11	
22401-1KC1C	DILKAR7C9H	
22401-1KC7C	DILKAR7C9H	
22401-1KT1B	DILZKAR6A11	
22401-1KT7B	DILZKAR6A11	
22401-1LA1C	DILKAR7B11	
22401-1LA7C	DILKAR7B11	
22401-1N506	BKR6E-N	
22401-1N516	BKR6E-N	
22401-1N517	BKR7E	
22401-1N567	PFR7G-11	
22401-1P114	PFR4G-11	
22401-1P115	PFR5G-11	
22401-1P116	PFR6G-11	
22401-1P117	PFR7G-11	
22401-1P175	PFR5G-11	
22401-1P175-Q0	PFR5G-11	
22401-1P175-VA	PFR5G-11	
22401-1P176	PFR6G-11	

NISSAN	→ NGK	Quick
22401-1P176-VA	PFR6G-11	
22401-1P176-WS	PFR6G-11	
22401-1W615	FR5AP-10	
22401-1W675	FR5AP-10	
22401-20J04	BKR4E	
22401-20J05	BKR5E	
22401-20J05-Q0	BKR5E	
22401-20J05-SN	BKR5E	
22401-20J05-VA	BKR5E	
22401-20J05-W0	BKR5E	
22401-20J06	BKR6E	
22401-20J07	BKR7E	
22401-20J16	BKR6E	
22401-21B15	BPR5E	
22401-21B16	BPR6E	
22401-21B17	BPR7E	
22401-27N15	PFR5B-11	
22401-27N15-VA	PFR5B-11	
22401-27N15-VB	PFR5B-11	
22401-27N16	PFR6B-11	
22401-27N65	PFR5B-11	
22401-27N66	PFR6B-11	
22401-27N67	PFR7B-11	
22401-27T15	PGR5A-11	
22401-27T65	PGR5A-11	
22401-27T66	PGR6A-11	
22401-2J200	BKR5EY-11	
22401-2J200-Q0	BKR5EY-11	
22401-2J200-VA	BKR5EY-11	
22401-2J206	BKR6EY-11	
22401-2J206-VA	BKR6EY-11	
22401-30R14	ZFR4E-11	
22401-30R15	ZFR5E-11	
22401-30R16	ZFR6E-11	
22401-30R75	ZFR5E-11	
22401-30R75-W1	ZFR5E-11	
22401-37P16	PFR6B-11C	
22401-37P76	PFR6B-11C	
22401-40F15	ZFR5D-11	
22401-40P15	PFR5B-11B	
22401-40P65	PFR5B-11B	
22401-40P66	PFR6B-11B	
22401-40V05	BCP5E	
22401-40V06	BCP6E	
22401-40V07	BCPR7E	
22401-50Y04	BKR4E-11	
22401-50Y05	BKR5E-11	
22401-50Y05-Q0	BKR5E-11	
22401-50Y05-VA	BKR5E-11	
22401-50Y05-W0	BKR5E-11	
22401-50Y06	BKR6E-11	
22401-50Y07	BKR7E-11	



NISSAN	→ NGK	Quick
22401-50Y75	BKR5E-11	
22401-50Y75-W0	BKR5E-11	
22401-53J04	BKR4EY	
22401-53J05	BKR5EY	
22401-53J05-VA	BKR5EY	
22401-53J06	BKR6EY	
22401-53J06-RB	BKR6EY	
22401-53J06-VA	BKR6EY	
22401-53J07	BKR7EY	
22401-53J15	PFR5B-9	
22401-53J65	PFR5B-9	
22401-53J66	PFR6B-9	
22401-53J67	PFR7B-9	
22401-53V15	PFR5B-9	
22401-53V16	PFR6B	
22401-53V17	PFR7B	
22401-55V17	PFR7B-D	
22401-58S15	PFR5A-11	
22401-58S16	PFR6A-11	
22401-58S17	PFR7A-11	
22401-59S16	PFR6A-11	
22401-5M015	PLFR5A-11	
22401-5M016	PLFR6A-11	
22401-5M075	PLFR5A-11	
22401-5M075-Q0	PLFR5A-11	
22401-5M075-SN	PLFR5A-11	
22401-5M075-VA	PLFR5A-11	
22401-5M075-W0	PLFR5A-11	
22401-60V06	BCPR6ES-11	
22401-6N215	LZFR5AQP	
22401-85E15	BKR5ES-11	
22401-85E16	BKR6ES-11	
22401-85E17	BKR7ES-11	
22401-85E75	BKR5ES-11	
22401-85E76	BKR6ES-11	
22401-88G75	BKR5EY	
22401-88G75-WS	BKR5EY	
22401-88G76	BKR6EY	
22401-88G76-WS	BKR6EY	
22401-8H314	LFR4AP-11	
22401-8H315	LFR5AP-11	
22401-8H375	LFR5AP-11	
22401-8H375-VA	LFR5AP-11	
22401-8H515	LFR5A-11	
22401-8H516	LFR6A-11	
22401-8H575	LFR5A-11	
22401-8H575-Q0	LFR5A-11	
22401-8H616	PLFR6A-9	
22401-8H676	PLFR6A-9	
22401-8P305	BKR5EQUPA	
22401-8P315	BKR5EQUPA	
22401-8P375	BKR5EQUPA	

NISSAN	→ NGK	Quick
22401-97E15	PFR5C-11	
22401-97E65	PFR5C-11	
22401-98E06	BKR6ES-11	
22401-9E075	FR5AP-10	
22401-AG214	PFR4G-11	
22401-AG215	PFR5P-11	
22401-AG275	PFR5P-11	
22401-AG315	BKR5EQUPA	
22401-AJ415	FR5AP-11	
22401-AL615	LFR5AQP	
22401-AL875	LFR5BP-11	
22401-AR015	LFR5AQP	
22401-AR716	LFR6A	
22401-BC01B	LFR5E-11	
22401-CK81	PLZKAR6A-11	
22401-CK81B	PLZKAR6A-11	
22401-CK87B	PLZKAR6A-11	
22401-CK87B-VA	PLZKAR6A-11	
22401-EA015	PLZKAR6A-11	
22401-ED815	LZKAR6AP-11	
22401-ED875	LZKAR6AP-11	
22401-ED875-Q0	LZKAR6AP-11	
22401-ED875-SN	LZKAR6AP-11	
22401-ED875-VA	LZKAR6AP-11	
22401-EW61B	DILKAR6A11	
22401-EW61C	DF7H-11B	
22401-EW67B	DILKAR6A11	
22401-F6516	PFR6A-11A	
22401-FU412	FR2B-D	
22401-FU42A	FR2B-D	
22401-HC000	BPR5ES-13	
22401-JA01B	DILKAR6A11	
22401-JA07B	DILZKAR6A11	
22401-JK01D	DF8H-11B	
22401-L1600	BP-2E	
22401-M7714	B4ES	
22401-M7715	B5ES	
22401-M7716	B6ES	
22401-M7717	B7ES	
22401-M7915	BR5ES	
22401-M7916	BR6ES	
22401-M7917	BR7ES	
22401-N8714	BP4ES-11	
22401-N8715	BP5ES-11	
22401-N8716	BP6ES-11	
22401-N8717	BP7ES-11	
22401-N8785	BP5ES-11	
22401-N8786	BP6ES-11	
22401-N8789	BP6ES-11	
22401-N8790	BP5ES-11	
22401-N8791	BP6ES-11	
22401-P8314	BPR4ES-11	

NISSAN	→ NGK	Quick
22401-P8315	BPR5ES-11	
22401-P8316	BPR6ES-11	
22401-P8317	BPR7ES-11	
22401-P8385-PC	BPR5ES-11	
22401-P8386-PC	BPR6ES-11	
22401-P8389	BPR4ES-11	
22401-P8390	BPR5ES-11	
22401-P8391	BPR6ES-11	
22401-P8614	BR4ES	
22401-P8616	BR6ES-11	
22401-P8617	BR7ES	
22401-P8816	B6ES-11	
22401-P8817	B7ES-11	
22401-S6015	BP5ES-13	
22401-V0515	BP5ES	
22401-V0516	BP6ES	
22401-V1414	BPR4ES	
22401-V1414-WL	BPR4ES	
22401-V1415	BPR5ES	
22401-V1416	BPR6ES	
22401-V1417	BPR7ES	
22401-V1484-PC	BPR4ES	
22401-V1485-PC	BPR5ES	
22401-V1486-PC	BPR6ES	
22401-V1490	BPR5ES	
22401-V1491	BPR6ES	
22401-V5014	BCPR4ES-11	
22401-V5015	BCP5ES-11	
22401-V5016	BCP6ES-11	
22401-V5017	BKR7E-11	
22401-V5085	BCP5ES-11	
22401-V5086	BCP6ES-11	
22401-VB000	BPR5E-11	
22401-VB006	BPR6E-11	
22401-VR306	IGR6B-10D	
22401-W8914	BP4ES	
22401-W8914-WL	BP4ES	
22401-W8915	BP5ES	
22401-W8915-SA	BP5ES	
22401-W8916	BP6ES	
22401-W8917	BP7ES	Q206
22401-W8985	BP5ES	
22401-W8985-PC	BP5ES	
22401-W8986	BP6ES	
22401-W8986-PC	BP6ES	
22401-W8990	BP5ES	
22401-W8991	BP6ES	
22401-W9815	BPR5ES	
22401-W9816	BPR6ES	
22401-W9817	BPR7ES	
22401-WA016	PFR6G-9	
22401-WA066	PFR6G-9	

NISSAN	→ NGK	Quick
22401-WA067	PFR7G-9	
22401-WD517	FR7AI-D	
22401-Y9015	BCPR5ET	
22401-Y9016	BCPR6ET	
22401-Y9017	BCPR7ET	
22401-Y9065	BCPR5ET	
22401-Y9066	BCP6ET	
22401-Y9067	BCP7ET	
22401-Y9215	BPR5ES	
22401-Y9264	BP4ES	
22401-Y9265	BP5ES	
22401-Y9266	BP6ES	
22401-ZE01B	DILFR5A11	
B2401-4A00A	IKR6G11	
B2401-89900	BPR5EIX	
B2401-89904	BP5EY	
B2401-89905	BP6EY	
B2401-89906	BCPR5EIX-11	
B2401-89907	BCPR6EIX-11	
B2401-89908	BPR5EY	
B2401-89909	BPR6EY	
B2401-M7715	B5ES	
B2401-M7915	BR5ES	
B2401-V1415	BPR5ES	
B2401-V1416	BPR6ES	
B2401-W8914	BP4ES	
B2401-W8915	BP5ES	
B2401-W8916	BP6ES	
B2401-W8917	BP7ES	Q206
BY480-BKR5E	BKR5EIX	
BY480-BKR6E	BKR6EIX	
BY480-BPR5E	BPR5EIX	
BY480-BPR6E	BPR6EIX	
BY480-BPR7E	BPR7EIX	
BY480-BPR8E	BPR8EIX	
BY480-BPR9E	BPR9EIX	
BY480-DCPR7	DCPR7EIX	
BY481-BCPR5	BCPR5EIX-11	
BY481-BCPR6	BCPR6EIX-11	
BY481-BKR5E	BKR5EIX-11	
BY481-BKR6E	BKR6EIX-11	
BY481-BKR7E	BKR7EIX-11	
BY481-BPR5E	BPR5EIX-11	
BY481-BPR6E	BPR6EIX-11	
BY481-LFR5A	LFR5AIX-11	
BY481-LFR6A	LFR6AIX-11	
BY481-ZFR5F	ZFR5FIX-11	
BY481-ZFR6F	ZFR6FIX-11	
BY482-BKR6E	LPG1	
BY482-BPR6E	LPG2	
BY483-BCPR5	BCPR5EIX-11P	
BY483-BCPR6	BCPR6EIX-11P	

NISSAN	→ NGK	Quick
BY483-BKR5E	BKR5EIX-11P	
BY483-BKR6E	BKR6EIX-11P	
BY483-HB6AI	HB6AIX-11P	
BY483-HB6BI	HB6BIX-11P	
BY483-LFR5A	LFR5AIX-11P	
BY483-LFR6A	LFR6AIX-11P	
BY483-ZFR5F	ZFR5FIX-11P	
BY483-ZFR6F	ZFR6FIX-11P	
BY484-BKR5E	BKR5EIX-P	
BY484-BKR6E	BKR6EIX-P	
BY484-BKR7E	BKR7EIX-P	
BY484-DCPR7	DCPR7EIX-P	
BY484-LFR6A	LFR6AIX-P	
BY484-LFR7A	LFR7AIX-P	
OMC	→ NGK	Quick
115 206	BP6HS	
387 694	B7HS	Q204
437 929	BPR7HS	Q215
445 098	D6HA	
502 177	B6HS	Q203
502 194	B7HS-10	
502 196	BR6S	
502 894	BUZ8H	
503 948	BPR6HS	
503 948	BPR6HS	Q214
503 948	BPR6HS	
503 949	BR6HS	Q209
503 950	BR6HS	Q209
504 082	BR6HS	Q209
509 921	BUHW	
509 922	BUHW-2	
509 924	BUZ8H	
509 925	BZ7HS-10	
509 926	BUHXW-1	
509 928	B6S	Q302
509 929	B7HS	Q204
584 918	DCPR7E	
771 770	BUZHW-2	
SUZUKI	→ NGK	Quick
09482-00006	B-4	
09482-00011	B-4H	
09482-00036	BP-4H	
09482-00051	B6S	Q302
09482-00053	B7S	
09482-00054	B6ES	
09482-00056	B8ES	Q201
09482-00059	BP6HS	
09482-00060	BP7HS	
09482-00064	BR6HIX	

SUZUKI	→ NGK	Quick
09482-00065	BR7HIX	
09482-00066	B9ES	Q202
09482-00074	BP6HS	
09482-00079	BR6ES	
09482-00082	B7HS	Q204
09482-00083	B7HS	Q204
09482-00084	BP6HS	
09482-00088	BR6HS	Q209
09482-00089	B7ES	
09482-00091	B8ES	Q201
09482-00095	B6HS	Q203
09482-00096	BR8EIX	
09482-00097	BR9EIX	
09482-00098	BR9ES	Q208
09482-00102	BR8HS	Q212
09482-00105	BP7HS	
09482-00114	BR8EIX	
09482-00115	BR9EIX	
09482-00116	BR7HS	Q211
09482-00117	BR7ES	
09482-00118	BP6ES	
09482-00120	BP5HS	
09482-00121	BR8ES	Q207
09482-00123	BP5EY	
09482-00124	BP5HS	
09482-00125	BPR-4H	
09482-00127	BR9ES	Q208
09482-00128	B6ES	
09482-00129	BP4EY	
09482-00130	BP4EY	
09482-00131	BP5ES	
09482-00136	BPR-4H	
09482-00139	BP7ES	Q206
09482-00141	BPR6HS	
09482-00141	BPR6HS	Q214
09482-00141	BPR6HS	
09482-00142	B-4H	
09482-00143	BR5HS	
09482-00144	D8EA	Q216
09482-00145	D8EA	Q216
09482-00147	BPR5HS	
09482-00149	DR8ES-L	Q218
09482-00151	B8HS	Q205
09482-00153	B7HS	Q204
09482-00155	BPR5ES	
09482-00157	BR8HS	Q212
09482-00159	BPR4EY	
09482-00161	BP4HS	
09482-00167	BPR5EY	
09482-00170	BP4HA	
09482-00171	BP4HS	
09482-00172	BP2HS	



SUZUKI	→ NGK	Quick
09482-00175	BP8ES	
09482-00177	BP6ES	
09482-00181	BR10EIX	
09482-00182	D7EA	
09482-00183	D7EA	
09482-00184	D9EA	
09482-00185	D9EA	
09482-00186	BP-4H	
09482-00188	BP6HS	
09482-00189	BP7HS	
09482-00190	B6HS	Q203
09482-00191	B7HS	Q204
09482-00192	B8HS	Q205
09482-00195	B7ES	
09482-00196	B8ES	Q201
09482-00198	B8HS	Q205
09482-00205	BPR4HS	
09482-00206	BPR4HS	
09482-00208	BR8EIX	
09482-00209	BR9EIX	
09482-00210	BR10EIX	
09482-00216	BP4EY-11	
09482-00217	BP5EY-11	
09482-00218	BP4EY-11	
09482-00219	BP5EY-11	
09482-00220	DR7ES	
09482-00221	DR8ES	Q217
09482-00222	DR7EA	
09482-00223	DR8EA	
09482-00225	B8ES	Q201
09482-00226	BP7ES	Q206
09482-00227	CM-6	
09482-00228	BP5HS	
09482-00229	BPR6HS	
09482-00229	BPR6HS	Q214
09482-00229	BPR6HS	
09482-00230	BR8HS	Q212
09482-00233-111	BR9ES	Q208
09482-00234	DR9EA	Q219
09482-00237	B8HS	Q205
09482-00239	BPR8ES	Q213
09482-00240-111	BPR8ES	Q213
09482-00244-111	BPR7HS	Q215
09482-00247-111	BR8ES	Q207
09482-00255	BPR7HS	Q215
09482-00258	BPMR6A	Q308
09482-00259	BP6HS	
09482-00261	BPMR4A	
09482-00262	BP5HS-10	
09482-00263	BP5HS-10	
09482-00264	BP6HS-10	
09482-00265	BP6HS-10	

SUZUKI	→ NGK	Quick
09482-00268	BP8HS	
09482-00269	B7HS-10	
09482-00277	BR7HS-10	
09482-00278	B8HS-10	
09482-00279	B8HS-10	
09482-00280	BR8HS-10	
09482-00281	BPR6HS	
09482-00281	BPR6HS	Q214
09482-00281	BPR6HS	
09482-00282	B5HS	
09482-00284	BP6EY-11	
09482-00285	BPR6ES-11	
09482-00286	BPR6EY-11	
09482-00287	BP5ES-11	
09482-00288	BP4ES	
09482-00289	B-4H	
09482-00290	BP-4H	
09482-00291	BP4HS	
09482-00294	C6HA	
09482-00295	C6HSA	
09482-00299	BPR6ES	
09482-00302-111	BPR6HS	Q214
09482-00303	BP6EY-11	
09482-00305	BP5HS	
09482-00306	BPR6HS	
09482-00306	BPR6HS	Q214
09482-00306	BPR6HS	
09482-00308	BR5HS	
09482-00309	B5HS	
09482-00312	BPR5EY-11	
09482-00314	CR7HSA	
09482-00316	BPR5HS	
09482-00317	C8HA	
09482-00320-111	CR8HSA	
09482-00321	C8HSA	
09482-00322	BPR5EIX	
09482-00325	BR8EIX	
09482-00327	BR6HS-10	
09482-00328	DP9EA-9	
09482-00330	DPR9EA-9	Q222
09482-00331-111	DPR7EA-9	Q220
09482-00332	DP8EA-9	
09482-00333-111	DP8EA-9	
09482-00334	DPR8EA-9	Q221
09482-00335-111	DPR7EA-9	Q220
09482-00338	B6HS-10	
09482-00339	B6HS-10	
09482-00340	CR6HS	Q223
09482-00341	BR6HS-10	
09482-00348	BR8ES	Q207
09482-00349	BR9ES	Q208
09482-00351	B9ES	Q202



SUZUKI	→ NGK	Quick
09482-00352	DP7EA-9	
09482-00354	DPR7EA-9	Q220
09482-00355-111	DPR7EA-9	Q220
09482-00358	BR4HS	
09482-00359	BPR5HS	
09482-00360	BR10ES	
09482-00362	ZGR5A	
09482-00363	BPR5EY	
09482-00365	J9A	
09482-00366	JR9B	Q224
09482-00367	BPR4HS	
09482-00368	DCP7E	
09482-00369	DCP7E	
09482-00370	BR8HS-10	
09482-00372	JR10B	
09482-00375	B8HS-10	
09482-00376	B8HS	Q205
09482-00378	DCPR8E	
09482-00379	DCPR8E	
09482-00381	PJR7A	
09482-00383	DCPR8EIX	
09482-00384	DCPR8EIX	
09482-00385	BP7ES	Q206
09482-00388	JR9B	Q224
09482-00389	JR9B	Q224
09482-00390	JR10B	
09482-00391	JR10B	
09482-00392	BP6ES	
09482-00393	DCP6E	
09482-00394	DCP6E	
09482-00397	JR9C	
09482-00398	DR7EA	
09482-00399	DR8EA	
09482-00400	DR9EA	Q219
09482-00401	JR8C	
09482-00404	LR8A	
09482-00406	CR6HSA	
09482-00407	CR6HSA	
09482-00408	CR7HSA	
09482-00409	BPR6ES	
09482-00410	CR9EK	Q230
09482-00411	CR9EK	Q230
09482-00412	CR8EK	
09482-00413	CR8EK	
09482-00414	CR7EK	
09482-00416-111	BPR5HS	
09482-00419	R2349-11	
09482-00420-111	BPR-4H	
09482-00421	BPR6ES-11	
09482-00426	BK6E	
09482-00427	BKR6E	
09482-00429	BKR6E	

SUZUKI	→ NGK	Quick
09482-00430	R0373A-10	
09482-00431	R0373A-11	
09482-00432	BPR5E	
09482-00433	BPR5EY-11	
09482-00434	BP7ES	Q206
09482-00446	DCPR6E	
09482-00447	DCPR6E	
09482-00448	DCPR7E	
09482-00449	DCPR7E	
09482-00450	DCPR8E	
09482-00452	ZGR5A	
09482-00454	BPR5EY	
09482-00456	CR8E	Q226
09482-00457	CR8E	Q226
09482-00458	CR9E	Q227
09482-00459	CR9E	Q227
09482-00460	CR10E	
09482-00461	CR10E	
09482-00462	CR10EK	
09482-00463	CR10EK	
09482-00464	BR8HCS-10	
09482-00467	BR9HS-10	
09482-00468	BPR5E	
09482-00470	BR8ECM	
09482-00472	BR9ECM	
09482-00473	BR9ECM	
09482-00474	BR10ECM	
09482-00476	BKR5E	
09482-00477	BKR5E	
09482-00478	B10ES	
09482-00479	DCPR7EIX	
09482-00481	DCPR8EIX	
09482-00482	DCPR7EIX	
09482-00484	DCPR8EIX	
09482-00485	CR8HSA	
09482-00486	BR8HCS-10	
09482-00487	BPR6ES	
09482-00488	DCPR7E	
09482-00491	JR8B	
09482-00493	BPR5E-11	
09482-00494	BKR6E-11	
09482-00495	BPR7ES	
09482-00496	BPR5E-11	
09482-00497	BKR5E-11	
09482-00498	BPR7ES	
09482-00499	BR8EIX	
09482-00500	BR9EIX	
09482-00501	BPR6EY	
09482-00502	BP5EY	
09482-00504	BPR5EY	
09482-00508	BKR6E-11	
09482-00509	R6918B-8	



SUZUKI	→ NGK	Quick
09482-00511	R6918B-7	
09482-00513	R0045Q-10	
09482-00514	R0045Q-11	
09482-00515	CR7E	Q225
09482-00516	CR7E	Q225
09482-00519	BR9EYA	
09482-00521	PGR5A	
09482-00522	BPR7HS-10	
09482-00523	BPR8HS	
09482-00525	IKR7A	
09482-00526	BR10EYA	
09482-00527	KR7AI	
09482-00528	CR6E	
09482-00530	BPR6HS	
09482-00530	BPR6HS	Q214
09482-00530	BPR6HS	
09482-00531	BP6HS	
09482-00532	B7HS-10	
09482-00533	BR7HS-10	
09482-00534	B6HS-10	
09482-00535	BR6HS-10	
09482-00537	DCPR9EIX	
09482-00540	PFR5G-11	
09482-00546	GR5AI-10	
09482-00547	IFR5E11	
09482-00548	IFR6E11	
09482-00549	IFR5J11	
09482-00550	IFR6J11	
09482-00554	CR7EIA-9	
09482-00556	CR8EIA-9	
09482-00557	CR9EIA-9	
09482-00558	CR9EIA-9	
09482-00561	BR8EG	
09482-00562	IFR5E11	
09482-00564	BR9EYA	
09482-00565	KR8AI	
09482-00566	BKR5E-11	
09482-00570	CR8EB	
09482-00581	CR8EKB	
09482-00582	CR9EKB	
09482-00584	CR8EIB-10	
09482-00590	CR6EIA-9	
09482-00597	CR8EIA-10	
09482-00602	IKR6G11	
09482-00603	IKR6G11	
09482-00606	SILFR6A11	
09482-00612	MR8AI9	
09482-00646	MR8E-9	
09482-00649	LKR6E	
09482-69001	BPR6HS	
09482-69001	BPR6HS	Q214
09482-69001	BPR6HS	

SUZUKI	→ NGK	Quick
09482-M0061-1	IKR6G11	
27117-50000	IRIWAY7	
27118-50000	R7433-8	
27119-00000	IRIMAC9	
94820-01197	B9ES	Q202
94820-0550	IFR6J11	
94820-0642	ILZKR7D8	
99000-69257-001	R2525-10	
99000-69571	C7HSA	
99000-69835-B6R	BR6HIX	
99000-69835-B7R	BR7HIX	
99000-69835-B8R	BR8HIX	
99000-69835-BP6	BPR6HIX	
99000-69835-BP7	BPR7HIX	
99000-69835-BR1	BR10EIX	
99000-69835-BR8	BR8EIX	
99000-69835-BR9	BR9EIX	
99000-69835-C6R	CR6HIX	
99000-69835-C7R	CR7HIX	
99000-69835-C8R	CR8HIX	
99000-69835-CR7	CR7EIX	
99000-69835-CR8	CR8EIX	
99000-69835-CR9	B8HCS	
99000-69835-DC7	DPR7EIX-9	
99000-69835-DC8	DCR8EIX	
99000-69835-DR8	DR8EIX	
99000-69835-DR9	DR9EIX	
99000-69835-PR8	DPR8EIX-9	
99000-69835-PR9	DPR9EIX-9	
99000-79A37-16E	BPR5EIX	
99000-79A37-20F	BR6HIX	
99000-79A37-22E	BR7EIX	
99000-79A37-24E	BR8EIX	
99000-79A37-24R	BR8EIX	
99000-79A37-27R	BR9EIX	
99000-79A37-29E	BR10EIX	
99000-79A37-31E	BR10EIX	
99000-79A37-K0P	BKR6EIX-11	
99000-79A37-U2F	CR7HIX	
99000-79A37-U7E	CR9EIX	
99000-79A37-W6X	BPR5EIX	
99000-79A45-B0E	BR10EIX	
99000-79A45-B6H	BR6HIX	
99000-79A45-B7E	BR7EIX	
99000-79A45-B7H	BR7HIX	
99000-79A45-B8E	BR8EIX	
99000-79A45-B8H	BR8HIX	
99000-79A45-B9E	BR9EIX	
99000-79A45-P8E	BPR8EIX	
99000-79B56	BPR4EY-11	
99000-79J80-K16	BKR5EIX-11	
99000-79J80-K20	BKR6EIX-11	

SUZUKI	→ NGK	Quick
99000-79J80-U22	DCPR7EIX	
99000-79J80-W16	BPR5EIX-11	
99000-79J80-W20	BPR6EIX-11	
99000-79J80-W22	BPR7EIX	
99000-79K24-22B	DPR7EIX-9	
99000-79K24-24B	DPR8EIX-9	
99000-79K24-27B	DPR9EIX-9	
99000-79K24-F22	CR7HIX	
99000-79K24-F24	CR8HIX	
99000-79K24-H24	CR8EHIX-9	
99000-79K24-H27	CR9EHIX-9	
99000-79K24-IW4	BR8EIX	
99000-79K24-IW7	BR9EIX	
99000-79K24-U22	CR7EIX	
99000-79K24-U24	CR8EIX	
99000-79K24-U27	B8HCS	
99000-79K24-W22	BR7HIX	
99000-79K24-W24	BR8HIX	
99000-79K24-W27	BR9HIX	
99000-79K24-W31	BR10EIX	
99000-79K24-X24	DR8EIX	
99000-79K24-X27	DR9EIX	
99000-79K60-BP6	BPR6EIX-11	
99000-79K60-DC7	DCPR7EIX	
99000-79K60-K5R	BKR5EIX	
99000-79K60-K6R	BKR6EIX	
99000-79K60-KR6	BKR6EIX-11	
99000-79K60-P5R	BPR5EIX	
99000-79K60-P6R	BPR6EIX	
99000-79K60-P7R	BPR7EIX	
99000-79K60-PR5	BPR5EIX-11	
99000-79K73-K16	BKR5EIX-11P	
99000-79K73-K20	BKR6EIX-11P	
99000-79K73-U22	DCPR7EIX-P	
99000-79L65-001	BKR6EIX-11P	
99000-79L65-002	BKR5EIX-P	
99000-79L65-003	BKR6EIX-P	
99000-79L65-004	DCPR7EIX-P	
99000-79L65-005	BKR5EIX-11P	
99000-79L65-006	BKR7EIX-P	
TANAKA	→ NGK	Quick
018-00300	BM6A	Q303
018-00502-200	BM6A	Q303
018-00502-21	BMR6A	Q307
018-00546-200	BMR6A	Q307
018-00562-200	BMR6A	Q307
018-01805-200	BM6A	Q303
018-02209	B6S	Q302
018-02233-200	BM7A	
018-02403	B7S	
018-02500	BM7A	

TANAKA	→ NGK	Quick
018-02607	BPM7A	Q305
018-04075-200	BPM6A	Q304
018-04093-20	BPMR8Y	
018-04603	BPR7HS	Q215
018-0635V-200	BM6F	
018-10201-200	BR6S	
018-11107-200	B6S	Q302
018-11401-200	B7S	
018-11600-200	BM7A	
018-11600-210	BM7A	
018-11610-200	BPM7A	Q305
018-11660-200	BPM6A	Q304
018-11660-21	BPMR6A	Q308
018-12700-200	BPR7HS	Q215
018-16005-20	CMR7H	
322-189	BPM6F	
623-45	BM6F	
668-5085	BPM6A	Q304
668-5086	BPMR6A	Q308
779-0117	BPMR6A	Q308
TECNICA	→ NGK	Quick
T 12	BP2ES	
T 15	BP5FS	
T 44	BP5EFS	
T 92	B-4H	
TORCH	→ NGK	Quick
5 580	BUR6ET	
8 012	BPR6EIX	
A 6 RTC	CR6HSA	
A 6 TC	C6HSA	
A 7 RTC	CR7HSA	
A 7 T	C7HSA	
A 7 TC	C7HSA	
A 8 RTC	CR8HSA	
A 8 TC	C8HSA	
B 8 RC	CR8E	Q226
C 6 RTC	D6HA	
CMR 7 H	CMR7H	
D 6 RTC 9	DPR6EA-9	
D 7	D7EA	
D 7 CA	D7EA	
D 7 RC	D7EA	
D 7 RTC	DPR7EA-9	Q220
D 7 RTC 9	DPR7EA-9	Q220
D 7 TC	DP7EA-9	
D 8 C	D8EA	Q216
D 8 RC	DR8EA	
D 8 RTC	DR8EA	
D 8 T	D8EA	Q216
DK 7 RTC	DCPR7E	



TORCH	→ NGK	Quick
E 4 RTC	BPR4HS	
E 4 TC	BP4HS	
E 5 RTC	BPR5HS	
E 5 T	BP-4H	
E 5 TC	BP5HS	
E 6 RC	BR6HS	Q209
E 6 RTC	BPR6HS	
E 6 RTC	BPR6HS	Q214
E 6 RTC	BPR6HS	
E 6 T	BP4HS	
E 7 C	B6HS	Q203
E 7 TJC	BUR6ET	
E 8 RC	BR8HS	Q212
E 8 RTC	BPR8HS	
F 5 C	B4ES	
F 5 RF	BPR5EY	
F 5 RTC	BPR5ES	
F 5 T	BP4ES	
F 5 TC	BP5ES	
F 6 RF	BPR6EY	
F 6 RTC	BPR6ES	
F 6 T	BP6ES	
F 7 C	B7ES	
F 7 RC	BR7ES	
F 7 RTC	BPR7ES	
F 7 RTJC	BUR6ET	
F 8 RC	BR8ES	Q207
F 8 RTC	BP8ES	
G 3 F	B-4	
G 3 TC	BP-4	
G 4 C	B-4	
G 4 RC	B-4	
G 5 RC	BR6S	
G 6	B6S	Q302
G 6 C	B6S	Q302
G 6 RC	BR6S	
GL 4	B4-LM	Q301
H 5	B6S	Q302
K 4 RTC 3	ZFR5F	
K 5 RF 11	BKR5E-11	
K 5 RTC 11	BKR5ES-11	
K 5 RTS	ZFR5P-G	
K 5 TC	BKR5ES-11	
K 6 RF	BKR6ES	
K 6 RF 11	BKR6E-11	
K 6 RTC	BKR5E-11	
K 6 RTC 11	BKR6ES-11	
K 7 RTC	BKR6ES	
K 7 TC	BCP6ES	
K 7 TJC	BCP6ET	
L 5 C	BM4A	
L 6	BM6A	Q303

TORCH	→ NGK	Quick
L 6 C	BM6A	Q303
L 6 RC	BMR6A	Q307
L 6 RTC	BPMR6A	Q308
L 6 T	BPM6A	Q304
L 6 TC	BPM6A	Q304
L 7	BM7A	
L 7 T	BPM7A	Q305
L 7 TC	BPM7A	Q305
L 7 Y	BM7A	
L 9	BM7A	
L 9 T	BPM7A	Q305
N 6	BM6F	
N 6 C	BM6F	
N 6 RC	BMR6F	
N 6 RTC	BPMR6F	
N 6 TC	BPM6F	
N 7 C	BM7F	
N 7 RC	BM7F	
N 9	BM7F	
P 5 RTC	BPR5FS	
P 5 TC	BP5FS	
P 6 RTC	BPR6FS	
P 6 TC	BP6FS	
P 7 RTC	BP7FS	
P 7 TC	BP7FS	
Q 5 RTC	BPR5EFS	
Q 5 TC	BP5EFS	
Q 6 RTC	BPR6EFS	
Q 6 TC	BP6EFS	
Q 7 TC	BP5EFS	
R 4 C	AB-6	
T 5 TC	AP5FS	
T 6 RTC	APR6FS	
T 6 TC	AP6FS	
T 1137 C	C7HSA	
VOLVO	→ NGK	Quick
1150 278	IFR6B11	
1367 528	BPR6ES	
1367 529	BPR6ES	
22401 AA670	IFR6B11	
2707 46	BPR6ES	
2712 39	IZFR6B	
2716 03	BKR6E	
2717 27	BKR6E	
3063 7308	PFR6B	
3063 7308 791	PFR6B	
3063 7308 887	PFR6B	
3063 7385	LFR6D	
3063 7385 496 A	LFR6D	
3065 0843	LFR6D	



VOLVO	→ NGK	Quick
3071 3859	LFR6D	
3073 1383	IFR6B11	
3073 1425	TR5B-13	
3073 1878	TR6AP-13	
3075 1468 889	ILFR6B	
3075 1469	LFR6D	
3075 1805	ILFR6B	
3075 1806	ILFR6B	
3075 8130	ILTR6G8G	
3077 7349	TR6AP-13	
3121 6183	ILFR6B	
3121 6184	ILFR6B	
3121 6297	ITR6F13	
3121 6525	ITR6F13	
3121 6674	ILFR6K8	
3127 2399	ILFR6K8	
3128 6359	DILFR6A11	
3133 0450	ILZTR6A8G	
3517 980	BKR6ES	
3650 843	LFR6D	
8642 660	BKR6ETUC	
8642 661	BKR6EQUA	
8670 058	BKR6EIX	
8687 990 H 939	IFR6B11	
8692 070	PFR6B	
8692 071	PFR6B	
8692 072	PFR6B	
8694 749	ITR6F13	
9146 775	BKR6ETUC	
9146 7759 01	BKR6EQUA	
9146 7759 07	BKR6EQUA	

YAMAHA	→ NGK	Quick
22401-AA670	IFR6B11	
90793-20001	BR7EIX	
90793-20002	BR8EIX	
90793-20003	BR9EIX	
90793-20004	BR10EIX	
90793-20005	BR6HIX	
90793-20006	BR7HIX	
90793-20007	BR8HIX	
90793-20008	BPR8EIX	
90793-20010	DR7EIX	
90793-20011	DR8EIX	
90793-20012	DR9EIX	
90793-20013	DPR8EIX-9	
90793-20014	DPR9EIX-9	
90793-20015	CR7HIX	
90793-20016	CR8HIX	
90793-20017	BR10HIX	
90793-20018	BR10EIX	

YAMAHA	→ NGK	Quick
90793-20021	DR7EIX	
90793-20022	DR8EIX	
90793-20023	DR9EIX	
90793-20024	BPR5EIX	
90793-20025	BPR8EIX	
90793-20026	BPR9EIX	
90793-20029	BR10EIX	
90793-20030	BR10EIX	
90793-20031	BR10EIX	
90793-20032	B10EG	
90793-20035	BP-4H	
90793-20036	BPR4HSA	
90793-20037	BP4HS-10	
90793-20038	BP5HS-10	
90793-20039	BP6HSA	
90793-20040	BP5ES-11	
90793-20045	BP6ES-11	
90793-20051	D8HA	
90793-20053	D10EA	
90793-20054	DP6EA-9	
90793-20057	BR6HS	Q209
90793-20058	BR7HS-10	
90793-20060	BR6ES	
90793-20062	BPR8ES	Q213
90793-20065	BPR5EY	
90793-20066	BPR5EY-11	
90793-20067	BPR6EY	
90793-20068	BPR6EY-11	
90793-20069	BPR7EY-11	
90793-20071	CR7HS	
90793-20072	CR8HS	
90793-20075	DR8HS	
90793-20076	DR7ES	
90793-20077	DR8ES	Q217
90793-20080	DPR7EA-9	Q220
90793-20081	CR7HIX	
90793-20082	CR8HIX	
90793-20083	DPR8EIX-9	
90793-20084	DPR9EIX-9	
90793-20085	BPR6HIX	
90793-20086	BPR7HIX	
90793-20090	BPM7A	Q305
90793-20093	BPM6A-10	
90793-20094	BPMR4A	
90793-20095	BPMR4A-10	
90793-20096	BPMR6A-10	
90793-20099	BR9HIX	
90793-20100	BR10HIX	
90793-20101	BPR6HIX	
90793-20102	BPR7HIX	
90793-20103	BPR8HIX	
90793-20106	BPR5EIX	



YAMAHA	→ NGK	Quick
90793-20107	BPR6EIX	
90793-20108	BPR5EIX-11	
90793-20109	BPR6EIX-11	
90793-20110	BPR7EIX	
90793-20112	BR8EIX	
90793-20113	BP8HS-10	
90793-20115	BR10EIX	
90793-20116	BPR5EIX	
90793-20117	BPR6EIX	
90793-20118	BR9EIX	
90793-20119	DPR8EIX-9	
90793-20120	DPR9EIX-9	
90793-20121	BR6FS	
90793-20122	CR8EIX	
90793-20123	CR9EIX	
90793-20124	CR8EIX	
90793-20125	CR9EIX	
90793-20127	BPR7ES-11	
90793-20128	BR4ES	
90793-20129	BPR7HS-10	
90793-20130	BR4HS	
90793-20131	BR5HS	
90793-20132	CR6HSA	
90793-20133	CR7HSA	
90793-20134	BR8EG	
90793-20135	BR9EG	
90793-20136	BR10EG	
90793-20138	BPR6EIX	
90793-20139	BR8ECM	
90793-20140	BR10ECM	
90793-20149	R0373A-10	
90793-20150	CR8EIX	
90793-20151	B8HCS	
90793-20152	DR8EIX	
90793-20153	DR9EIX	
90793-20154	DPR8EIX-9	
90793-20155	DPR9EIX-9	
90793-20156	BPR6HIX	
90793-20157	BPR7HIX	
90793-20158	BR6HIX	
90793-20159	BR7HIX	
90793-20160	BR8EIX	
90793-20161	BR9EIX	
90793-20162	CR8EHIX-9	
90793-20163	CR9EHIX-9	
90793-20164	BR8HIX	
90793-20165	BR10EIX	
90793-20166	BPR8HIX	
90793-20167	BPR5EIX	
90793-20168	BPR6EIX	
90793-20169	CR5HIX	
90793-20170	CR6HIX	

YAMAHA	→ NGK	Quick
90793-20171	CR7HIX	
90793-20172	CR7EIX	
90793-20173	DPR7EIX-9	
90793-20174	CR8HIX	
90793-20175	BPR7EIX	
90793-22001	BR8HIX	
90793-22003	DPR7EIX-9	
90793-22008	B5ES	
90793-22010	B9ES	Q202
90793-22031	BR7HS	Q211
90793-22032	BR8HS	Q212
90793-22033	BR7HS-10	
90793-22034	BR8HS-10	
90793-22035	BR6ES	
90793-22036	BR7ES	
90793-22037	BR9ES	Q208
90793-22039	BR8HS	Q212
90793-22045	BPR6EY-11	
90793-22047	DPR7EA-9	Q220
90793-22059	CR7HIX	
90793-22064	BR9EIX	
90793-22065	BR9EIX	
90793-22086	CR9EIX	
90793-22088	BR8EIX	
90793-22089	BR9EIX	
90793-22091	BR10EIX	
90793-22093	CR7EIX	
90793-22094	CR8EIX	
90793-22095	B8HCS	
90793-22096	CR8EHIX-9	
90793-22097	CR9EHIX-9	
90793-22098	DPR7EIX-9	
90793-22099	DPR8EIX-9	
90793-22100	DPR9EIX-9	
90793-22101	BPR7EIX	
90793-22107	DR8EIX	
90793-22108	DR9EIX	
90793-22109	BR7HIX	
90793-22110	BR8HIX	
90793-22111	BR9HIX	
90793-22112	BPR5EIX-11	
90793-22114	CR7HIX	
90793-22115	CR8HIX	
9079E-NG001	BR8EIX	
9079E-NG002	BR9EIX	
9079E-NG003	BR10EIX	
9079E-NG004	BR8EIX	
9079E-NG005	BR9EIX	
90890-78064	C8HA	
90890-78065	D6HA	
90890-78066	D6EA	
90890-78068	DP9EA-9	



YAMAHA	→ NGK	Quick
90890-78070	B9HS-10	
90890-78071	BP8HS	
90890-78072	BP9ES	
90890-78073	BP4HA	
90890-78074	BM6A	Q303
90890-78075	BM7A	
90890-78076	BPM6A	Q304
90890-78077	BR9HS	
90890-78078	BPR7EIX	
90890-78079	BPR6EIX	
90890-78082	BR10EIX	
90890-78086	BR8ES	Q207
90890-78094	B6HS	Q203
90890-78097	BP4HS	
90890-78102	BM6A	Q303
90890-78106	BPR7EIX	
90890-78108	BR7EIX	
90890-78110	BR9EIX	
90890-78111	BR10EIX	
90890-78112	BR10EIX	
90890-78115	BR9HIX	
90890-78116	BR10HIX	
90890-78118	DR8EIX	
90893-22113	BPR6EIX-11	
94700-00039	B6HS	Q203
94700-00040	B7HS	Q204
94700-00041	B8HS	Q205
94700-00043	B6ES	
94700-00044	B7ES	
94700-00045	B8ES	Q201
94700-00050	BP7HS	
94700-00108	BP6HS	
94700-00110	BR7HS	Q211
94700-00111	BR6ES	
94700-00117	BP7ES	Q206
94700-00118	BP8ES	
94700-00157	D8EA	Q216
94700-00159	BP4HS	
94700-00168	BP5HS	
94700-00189	D7EA	
94700-00195	BR8HS	Q212
94700-00198	BPR6HS	
94700-00198	BPR6HS	Q214
94700-00198	BPR6HS	
94700-00203	DR8ES-L	Q218
94700-00204	BR8ES	Q207
94700-00208	DR7ES	
94700-00213	C6HA	
94700-00218	BPR7ES	
94700-00219	BPR8ES	Q213
94700-00227	BPR7HS	Q215
94700-00232	BP6HS-10	

YAMAHA	→ NGK	Quick
94700-00234	BPR6ES	
94700-00241	DPR8EA-9	Q221
94700-00248	BR6HS	Q209
94700-00250	CR7HS	
94700-00254	C7HSA	
94700-00256	C6HSA	
94700-00258	BPR4HS	
94700-00261	BR9ES	Q208
94700-00262	DPR7EA-9	Q220
94700-00263	DP7EA-9	
94700-00268	BP8HS	
94700-00275	DP8EA-9	
94700-00280	BPR8HS	
94700-00282	CR6HS	Q223
94700-00292	BPR6HS-10	
94700-00318	CR9E	Q227
94700-00330	CR8E	Q226
94700-00333	DR8EA	
94700-00336	BPR5HS	
94700-00340	DR9EA	Q219
94700-00345	DR7EA	
94700-00353	CR7E	Q225
94700-00361	DPR9EA-9	Q222
94700-00366	CR7HSA	
94700-00372	CR6HSA	
94700-00375	DPR6EA-9	
94700-00381	CR6E	
94700-00394	R0373A-10	
94700-00397	B9HS	
94700-00402	CR10EK	
94700-00403	CR9EK	Q230
94700-00406	DPR5EA-9	
94700-00408	CR9EIA-9	
94700-00410	CR9E	Q227
94700-00411	CR8E	Q226
94700-00420	CPR7EA-9	
94700-00424	LMAR9E-J	
94700-00825	BP7HS-10	
94700-00835	C7HSA	
94700-00840	CR7E	Q225
94700-00841	C6HSA	
94700-00850	C6HSA	
94700-00856	CR7HSA	
94700-00866	CPR8EA-9	
94700-00871	CPR9EA-9	
94700-00879	CR6HSA	
94701-00039	B6HS	Q203
94701-00040	B7HS	Q204
94701-00041	B8HS	Q205
94701-00042	B9HS	
94701-00043	B6ES	
94701-00044	B7ES	



YAMAHA	→ NGK	Quick
94701-00045	B8ES	Q201
94701-00046	B9ES	Q202
94701-00048	B8HCS	
94701-00050	BP7HS	
94701-00061	BR8EIX	
94701-00063	BR9EIX	
94701-00069	B5HS	
94701-00078	B5ES	
94701-00108	BP6HS	
94701-00110	BR7HS	Q211
94701-00111	BR6ES	
94701-00112	BR7ES	
94701-00113	BR8EIX	
94701-00116	BP6ES	
94701-00117	BP7ES	Q206
94701-00118	BP8ES	
94701-00148	BR8HIX	
94701-00157	D8EA	Q216
94701-00159	BP4HS	
94701-00160	B8HS-10	
94701-00168	BP5HS	
94701-00188	BR9ES	Q208
94701-00189	D7EA	
94701-00193	BR9EIX	
94701-00194	BPR5HS	
94701-00195	BR8HS	Q212
94701-00198	BPR6HS	
94701-00198	BPR6HS	Q214
94701-00198	BPR6HS	
94701-00203	DR8ES-L	Q218
94701-00204	DR8ES	Q217
94701-00208	DR7ES	
94701-00211	BPMPR6A	Q308
94701-00217	B7HS-10	
94701-00218	BPR7ES	
94701-00219	BPR8ES	Q213
94701-00227	BPR7HS	Q215
94701-00232	BP6HS-10	
94701-00234	BPR6ES	
94701-00237	BP8HS-10	
94701-00241	DPR8EA-9	Q221
94701-00247	BR8HS-10	
94701-00248	BR6HS	Q209
94701-00250	CR7HS	
94701-00251	BR9HS	
94701-00254	C7HSA	
94701-00256	C6HSA	
94701-00258	BPR4HS	
94701-00262	DPR7EA-9	Q220
94701-00263	DP7EA-9	
94701-00264	BP7HS-10	
94701-00266	D9EA	

YAMAHA	→ NGK	Quick
94701-00267	BP8ES	
94701-00268	BP8HS	
94701-00273	B6HS-10	
94701-00274	BR6HS-10	
94701-00275	DP8EA-9	
94701-00280	BPR8HS	
94701-00282	CR6HS	Q223
94701-00284	BPR6EIX	
94701-00285	BPR6EIX	
94701-00287	DR8ES	Q217
94701-00292	BPR6HS-10	
94701-00300	CR5HS	
94701-00309	BR9HS-10	
94701-00310	C2H	
94701-00311	BR5ES	
94701-00315	C9E	
94701-00318	CR9E	Q227
94701-00324	BR9EG	
94701-00325	B9EG	
94701-00328	BPR5ES	
94701-00330	CR8E	Q226
94701-00333	DR8EA	
94701-00340	DR9EA	Q219
94701-00345	DR7EA	
94701-00349	BR7ES	
94701-00353	CR7E	Q225
94701-00354	CR4HSA	
94701-00356	BR10ES	
94701-00358	C7E	
94701-00361	DPR9EA-9	Q222
94701-00365	BR6FS	
94701-00366	CR7HSA	
94701-00371	BR7HS-10	
94701-00372	CR6HSA	
94701-00375	DPR6EA-9	
94701-00381	CR6E	
94701-00386	CR10EK	
94701-00395	CR9EK	Q230
94701-00402	CR10EK	
94701-00403	CR9EK	Q230
94701-00406	DPR5EA-9	
94701-00407	CR9EIA-9	
94701-00408	CR9EIA-9	
94701-00410	CR9E	Q227
94701-00411	CR8E	Q226
94701-00415	CPR8EA-9	
94701-00420	CPR7EA-9	
94701-00422	LMAR7A-9	
94701-00423	LMAR6A-9	
94701-00424	LMAR9E-J	
94701-00434	LMAR8G	
94701-00N02	BR9EIX	



YAMAHA	→ NGK	Quick
94702-00039	B6HS	Q203
94702-00040	B7HS	Q204
94702-00041	B8HS	Q205
94702-00044	B7ES	
94702-00045	B8ES	Q201
94702-00046	B9ES	Q202
94702-00069	B5HS	
94702-00111	BR6ES	
94702-00149	B7HS	Q204
94702-00160	B8HS-10	
94702-00188	BR9ES	Q208
94702-00193	BR9EIX	
94702-00195	BR8HS	Q212
94702-00204	BR8ES	Q207
94702-00211	BPMR6A	Q308
94702-00217	B7HS-10	
94702-00227	BPR7HS	Q215
94702-00234	BPR6ES	
94702-00247	BR8HS-10	
94702-00248	BR6HS	Q209
94702-00249	BR5HS	
94702-00251	BR9HS	
94702-00271	BR7HS-10	
94702-00272	BR7HS	Q211
94702-00273	B6HS-10	
94702-00274	BR6HS-10	
94702-00309	BR9HS-10	
94702-00317	B9HS-10	
94702-00323	B8EG	
94702-00324	BR9EG	
94702-00325	B9EG	
94702-00326	BR8EG	
94702-00331	BPR4ES	
94702-00343	BR4ES	
94702-00348	BPR2ES	
94702-00349	BR7ES	
94702-00351	BP8ES	
94702-00356	BR10ES	
94702-00357	BR9ECM	
94702-00367	B10EG	
94702-00368	BR10EG	
94702-00372	CR6HSB	
94702-00373	R7376-10	
94702-00374	R7282-105	
94702-00383	BR9ECS	
94702-00384	BR10ECS	
94702-00391	LFR5A-11	
94702-00396	BR8ES-11	
94702-00399	BKR7ES-11	
94702-00400	LFR6A-11	
94702-00401	BKR6ES-11	
94702-00403	CR9EKB	

YAMAHA	→ NGK	Quick
94702-00404	BKR7EKU	
94702-00405	BKR6EKU	
94702-00409	CR9EB	
94702-00412	BKR6E	
94702-00418	DPR6EB-9	
94702-00419	CR4HSB	
94702-00427	LFR6A	
94702-00428	CPR8EB-9	
94702-00429	LKR7E	
94702-00803	BP7HS-10	
94702-00808	BR8ES	Q207
94703-00001	B-4H	
94703-00039	B6HS	Q203
94703-00040	B7HS	Q204
94703-00041	B8HS	Q205
94703-00042	B9HS	
94703-00043	B6ES	
94703-00044	B7ES	
94703-00045	B8ES	Q201
94703-00046	B9ES	Q202
94703-00050	BP7HS	
94703-00059	BR7HIX	
94703-00060	BR9HIX	
94703-00062	BR6HIX	
94703-00065	BR7EIX	
94703-00069	B5HS	
94703-00074	BR8EIX	
94703-00075	BR9EIX	
94703-00078	B5ES	
94703-00108	BP6HS	
94703-00109	BP-2E	
94703-00110	BR7HS	Q211
94703-00112	BR7ES	
94703-00113	BR8EIX	
94703-00114	BR9EIX	
94703-00116	BP6ES	
94703-00117	BP7ES	Q206
94703-00118	BP8ES	
94703-00133	BP5ES	
94703-00143	BR8HIX	
94703-00148	BR8HIX	
94703-00157	D8EA	Q216
94703-00159	BP4HS	
94703-00160	B8HS-10	
94703-00168	BP5HS	
94703-00181	D8EA	Q216
94703-00188	BR9ES	Q208
94703-00189	D7EA	
94703-00191	BP4ES	
94703-00194	BPR5HS	
94703-00198	BPR6HS	
94703-00198	BPR6HS	Q214

YAMAHA	→ NGK	Quick
94703-00198	BPR6HS	
94703-00203	DR8ES-L	Q218
94703-00204	BR8ES	Q207
94703-00207	B4ES	
94703-00213	C6HA	
94703-00214	C6HSA	
94703-00216	C7HSA	
94703-00217	B7HS-10	
94703-00218	BPR7ES	
94703-00220	BPR7ES	
94703-00221	BP2HS	
94703-00222	DR8EA	
94703-00223	BP6HS	
94703-00227	BPR7HS	Q215
94703-00232	BP6HS-10	
94703-00234	BPR6ES	
94703-00235	BPR6HS-10	
94703-00241	DPR7EA-9	Q220
94703-00254	C7HSA	
94703-00256	C6HSA	
94703-00258	BPR4HS	
94703-00262	DPR7EA-9	Q220
94703-00263	DP7EA-9	
94703-00264	BP7HS-10	
94703-00265	CR7HSA	
94703-00266	D9EA	
94703-00267	BP8ES	
94703-00273	B6HS-10	
94703-00275	DP8EA-9	
94703-00277	BR9EIX	
94703-00279	BR8EIX	
94703-00282	CR6HS	Q223
94703-00307	C9E	
94703-00310	C2H	
94703-00311	BR5ES	
94703-00314	C8E	
94703-00315	C9E	
94703-00318	CR9E	Q227
94703-00319	CR9E	Q227
94703-00320	BP7ES-11	
94703-00323	B8EG	
94703-00325	B9EG	
94703-00327	BPR7HS	Q215
94703-00328	BPR5ES	
94703-00329	CR8E	Q226
94703-00330	CR8E	Q226
94703-00331	BPR4ES	
94703-00333	DR8EA	
94703-00334	B-2H	
94703-00340	DR9EA	Q219
94703-00345	DR7EA	
94703-00352	CR7E	Q225

YAMAHA	→ NGK	Quick
94703-00353	CR7E	Q225
94703-00355	BR7HS	Q211
94703-00381	CR6E	
94703-00406	DPR5EA-9	
94703-00410	CR9E	Q227
94703-00411	CR8E	Q226
94703-00420	CPR7EA-9	
94703-00422	LMAR7A-9	
94703-00423	LMAR6A-9	
94703-00424	LMAR9E-J	
94709-00193	BR9EIX	
94709-00195	BR8HS	Q212
94709-00211	BPMR6A	Q308
94709-00247	BR8HS-10	
94709-00248	BR6HS	Q209
94709-00271	BR7HS-10	
94709-00274	BR6HS-10	
94709-00309	BR9HS-10	
94709-00324	BR9EG	
94709-00326	BR8EG	
94709-00337	BR10EIX	
94709-00342	BPR4EY	
94709-00348	BPR2ES	
94709-00357	BR9ECM	
94709-00372	CR6HSB	
94709-00373	R7376-10	
94709-00383	BR9ECS	
94709-00384	BR10ECS	
94709-00391	LFR5A-11	
94709-00396	BR8ES-11	
94709-00399	BKR7ES-11	
94709-00400	LFR6A-11	
94709-00401	BKR6ES-11	
94709-00404	BKR7EKU	
94709-00405	BKR6EKU	
94709-00409	CR9EB	
94709-00418	DPR6EB-9	
94709-00419	CR4HSB	
94793-20036	BPR4HSA	
94793-20037	BP4HS-10	
94793-20038	BP5HS-10	
LKR 6 E 0000000	LKR6E	
Q1QDNS 021000	DCPR7EIX	
Q1QDNS 026000	IRITOP7	
YANMAR	→ NGK	Quick
124190-78010	BPR4ES	
160110-78011	B6HS	Q203
160232-78010	B-4H	
160560-78010	BPMR4A	
160610-78010	BP4HS	
160690-78010	BP6ES	

BERU	→ NGK	D-Power
0 100 220 103	Y-207T	
0 100 220 113	Y-204RS	
0 100 220 114	Y-112M1	
0 100 220 115	Y-112R1	
0 100 220 118	Y-705RS	
0 100 220 206	Y-403T	
0 100 221 101	Y-302	
0 100 221 102	Y-208T	
0 100 221 103	Y-208T	
0 100 221 105	Y-918J	DP2
0 100 221 106	Y-208T	
0 100 221 107	Y-924J	DP1
0 100 221 132	Y-907R	
0 100 221 133	Y-924J	DP1
0 100 221 135	Y-924J	DP1
0 100 221 141	Y-909R	
0 100 221 144	Y-910J	DP3
0 100 221 145	Y-924J	DP1
0 100 221 146	Y-910J	DP3
0 100 221 147	Y-115T1	
0 100 221 148	Y-128T	
0 100 221 149	Y-117RS	
0 100 221 151	Y-118T1	
0 100 221 152	Y-204TS1	
0 100 221 154	Y-107R	
0 100 221 163	Y-924J	DP1
0 100 221 170	Y-739R	
0 100 221 186	Y-306R	
0 100 221 206	Y-404	
0 100 221 209	Y-403-1	
0 100 221 210	Y-405	
0 100 221 301	Y-811	
0 100 222 101	Y-118R	
0 100 222 102	Y-168R	
0 100 222 106	Y-508J	
0 100 222 301	Y-810	
0 100 222 302	Y-810	
0 100 226 129	Y-729U	DP34
0 100 226 163	Y-913J	
0 100 226 164	Y-933J	DP25
0 100 226 170	Y-712RS	
0 100 226 171	Y-712RS	
0 100 226 173	Y-918J	DP2
0 100 226 180	Y-146R	
0 100 226 182	Y-147T	
0 100 226 183	Y-115R1	
0 100 226 184	Y-730U	DP17
0 100 226 185	Y-924J	DP1
0 100 226 186	Y-924J	DP1
0 100 226 188	Y-503J	DP10
0 100 226 189	Y-924J	DP1
0 100 226 194	Y-707RS	

BERU	→ NGK	D-Power
0 100 226 198	Y-910J	DP3
0 100 226 206	Y-604J	
0 100 226 207	Y-710J	
0 100 226 208	Y-711J	DP28
0 100 226 209	Y-307R	
0 100 226 227	Y-732J	DP4
0 100 226 229	Y-924J	DP1
0 100 226 233	Y-722JS	
0 100 226 234	Y-916J	DP6
0 100 226 235	Y-925J	DP16
0 100 226 237	Y-933J	DP25
0 100 226 238	Y-740U	DP22
0 100 226 242	Y-703R	
0 100 226 243	Y-715R	
0 100 226 245	Y-506J	DP7
0 100 226 246	Y-738U	
0 100 226 249	Y-928U	DP29
0 100 226 250	Y-929U	DP41
0 100 226 255	Y-605J	
0 100 226 258	Y-930U	DP30
0 100 226 299	Y-927J	DP19
0 100 226 300	Y-748U	DP14
0 100 226 302	CZ261	
0 100 226 312	Y1038J	
0 100 226 336	Y-701J	DP39
0 100 226 338	Y-501U	DP31
0 100 226 343	Y-741U	DP20
0 100 226 344	Y-504J	DP24
0 100 226 351	Y-517J	
0 100 226 352	Y-530J	
0 100 226 354	Y-502R	
0 100 226 362	Y-507J	DP32
0 100 226 365	Y-746J	DP38
0 100 226 366	Y-924J	DP1
0 100 226 371	Y-503J	DP10
0 100 226 372	Y-747U	DP26
0 100 226 373	Y-732J	DP4
0 100 226 375	Y-516J	DP12
0 100 226 379	Y-745U	DP11
0 100 226 381	Y-937J	
0 100 226 384	Y-524J	DP27
0 100 226 385	Y-548J	DP75
0 100 226 391	Y-939J	DP43
0 100 226 392	Y-543J	DP46
0 100 226 417	Y-523J	DP37
0 100 226 422	Y-749J	
0 100 226 432	Y-926U	
0 100 226 436	Y-534J	DP36
0 100 226 475	Y-532J	
0 100 226 480	Y-542J	DP45
0 100 226 482	Y-741U	DP20
0 100 226 492	Y1005J	DP56



BERU	→ NGK	D-Power
0 100 226 494	Y1031J	DP71
0 100 226 495	Y-603J	DP60
0 100 226 497	Y-541J	DP42
0 100 226 504	Y-732J	DP4
0 100 226 511	Y-733J	DP13
0 100 226 513	CZ260	
0 100 226 514	CZ259	
0 100 226 517	Y-536J	DP81
0 100 226 520	Y-904M1	
0 100 226 522	Y-527J	DP67
0 100 226 526	Y-529J	
0 100 226 527	Y-531J	DP44
0 100 226 538	Y1012J	DP65
0 100 226 568	Y1013J	DP63
0 100 226 577	Y1001J1	
0 100 226 639	Y1030J	DP70
0 100 230 101	Y-181T	
0 100 230 102	Y-162R1	
0 100 230 107	Y-755RS	
0 100 231 104	Y-157R	
0 100 231 107	Y-197R	
0 100 231 109	Y-757RS	
0 100 231 114	Y-197T	
0 100 266 002	Y-547AS	DP47
0 100 266 008	Y-607AS	DP50
0 100 266 009	YE14	DP48
0 100 266 011	Y8002AS	DP51
0 100 266 016	Y-609AS	DP49
0 100 266 031	Y9004AS	
0 100 266 032	Y1035AS	DP77
0 100 266 033	Y1036AS	
0 100 266 034	Y9003AS	DP78
0 100 266 037	Y1039AS	DP80
0 100 266 040	Y1002AS	DP57
0 100 266 068	Y8001AS	DP58
0 100 266 075	Y1010AS	DP88
0 100 266 079	Y8010AS	
0 100 276 003	Y8005J	DP64
0 100 276 004	YE04	DP40
0 100 276 005	YE12	
0 100 276 008	Y8003J	DP62
0 100 276 012	YE05	DP73
0 100 276 014	YE13	
0 100 276 015	YE07	
0 100 276 024	YE08	
0 100 800 031	Y-519J	DP61
0 100 800 035	CZ258	
0 106 671 108	CZ104	DP52
2 510 029 123	Y-606J	
162 MJ	Y-207T	
888 MJ	Y-204RS	
889 MJ	Y-112M1	

BERU	→ NGK	D-Power
892 MJ	Y-112R1	
920 MJ	Y-705RS	
137 MJ	Y-403T	
112 M	Y-302	
151 MJ	Y-208T	
105 MN	Y-208T	
601 MJ	Y-918J	DP2
602 MJ	Y-208T	
603 MJ	Y-924J	DP1
631 MJ	Y-907R	
636 MJ	Y-924J	DP1
642 MJ	Y-924J	DP1
657 MJ	Y-909R	
661 MJ	Y-910J	DP3
663 MJ	Y-924J	DP1
666 MJ	Y-910J	DP3
673 MJ	Y-115T1	
678 MJ	Y-128T	
685 MJ	Y-117RS	
688 MJ	Y-118T1	
689 MJ	Y-204TS1	
705 MJ	Y-107R	
719 MJ	Y-924J	DP1
730 MJ	Y-739R	
749 MJ	Y-306R	
155 MJ	Y-404	
106 MJ	Y-403-1	
130 MJ	Y-405	
170 MJ	Y-811	
894 MJ	Y-118R	
896 MJ	Y-168R	
107 MJ	Y-810	
108 MJ	Y-810	
783 MJ	Y-729U	DP34
852 MJ	Y-913J	
844 MJ	Y-933J	DP25
853 MJ	Y-712RS	
854 MJ	Y-712RS	
857 MJ	Y-918J	DP2
886 MJ	Y-146R	
897 MJ	Y-147T	
898 MJ	Y-115R1	
905 MJ	Y-730U	DP17
908 MJ	Y-924J	DP1
909 MJ	Y-924J	DP1
912 MJ	Y-503J	DP10
917 MJ	Y-924J	DP1
921 MJ	Y-707RS	
927 MJ	Y-910J	DP3
944 MJ	Y-604J	
946 MJ	Y-710J	
947 MJ	Y-711J	DP28

BERU	→ NGK	D-Power
945 MJ	Y-307R	
855 MJ	Y-732J	DP4
954 MJ	Y-924J	DP1
955 MJ	Y-722JS	
858 MJ	Y-916J	DP6
948 MJ	Y-925J	DP16
959 MJ	Y-933J	DP25
999 MJ	Y-740U	DP22
967 MJ	Y-703R	
968 MJ	Y-715R	
963 MJ	Y-506J	DP7
964 MJ	Y-738U	
970 MJ	Y-928U	DP29
961 MJ	Y-929U	DP41
860 MJ	Y-930U	DP30
991 MJ	Y-927J	DP19
GV 889	Y-112M1	
GV 892	Y-112R1	
GV 920	Y-705RS	
GV 105	Y-208T	
GV 602	Y-208T	
GV 603	Y-924J	DP1
GV 631	Y-907R	
GV 636	Y-924J	DP1
GV 642	Y-924J	DP1
GV 657	Y-909R	
GV 661	Y-910J	DP3
GV 663	Y-924J	DP1
GV 666	Y-910J	DP3
GV 673	Y-115T1	
GV 678	Y-128T	
GV 685	Y-117RS	
GV 688	Y-118T1	
GV 705	Y-107R	
GV 719	Y-924J	DP1
GV 730	Y-739R	
GV 749	Y-306R	
GV 894	Y-118R	
GN 057	Y-508J	
GV 107	Y-810	
GV 108	Y-810	
GV 783	Y-729U	DP34
GV 852	Y-913J	
GV 844	Y-933J	DP25
GN 853	Y-712RS	
GN 854	Y-712RS	
GN 857	Y-918J	DP2
GV 886	Y-146R	
GV 897	Y-147T	
GN 905	Y-730U	DP17
GN 908	Y-924J	DP1
GN 909	Y-924J	DP1

BERU	→ NGK	D-Power
GN 912	Y-503J	DP10
GN 917	Y-924J	DP1
GV 921	Y-707RS	
GN 927	Y-910J	DP3
GN 944	Y-604J	
GV 946	Y-710J	
GV 947	Y-711J	DP28
GN 855	Y-732J	DP4
GN 954	Y-924J	DP1
GN 955	Y-722JS	
GN 858	Y-916J	DP6
GN 948	Y-925J	DP16
GN 959	Y-933J	DP25
GN 999	Y-740U	DP22
GV 967	Y-703R	
GV 968	Y-715R	
GN 963	Y-506J	DP7
GN 964	Y-738U	
GN 970	Y-928U	DP29
GN 961	Y-929U	DP41
GN 985	Y-605J	
GN 860	Y-930U	DP30
GN 991	Y-927J	DP19
GN 992	Y-748U	DP14
GN 994	CZ261	
GN 997	Y1038J	
GN 005	Y-701J	DP39
GN 008	Y-501U	DP31
GN 007	Y-741U	DP20
GN 027	Y-504J	DP24
GN 026	Y-517J	
GN 039	Y-530J	
GN 012	Y-502R	
GN 024	Y-507J	DP32
GN 010	Y-746J	DP38
GN 013	Y-924J	DP1
GN 016	Y-503J	DP10
GN 017	Y-747U	DP26
GN 018	Y-732J	DP4
GN 019	Y-516J	DP12
GN 003	Y-745U	DP11
GN 022	Y-937J	
GN 993	Y-524J	DP27
GN 939	Y-548J	DP75
GN 030	Y-939J	DP43
GN 015	Y-543J	DP46
GN 033	Y-523J	DP37
GN 035	Y-749J	
925 MJ	Y-926U	
GN 041	Y-534J	DP36
GN 043	Y-532J	
GN 042	Y-542J	DP45



BERU	→ NGK	D-Power
GN 046	Y-741U	DP20
GN 054	Y1005J	DP56
GN 055	Y1031J	DP71
GN 103	Y-603J	DP60
GN 104	Y-541J	DP42
GN 107	Y-733J	DP13
GN 102	CZ260	
GN 101	CZ259	
GN 060	Y-536J	DP81
GN 061	Y-904M1	
GN 062	Y-527J	DP67
GN 064	Y-529J	
GN 065	Y-531J	DP44
GN 108	Y1012J	DP65
GN 110	Y1013J	DP63
GN 095	Y1001J1	
GN 097	Y1030J	DP70
887 MJ	Y-181T	
890 MJ	Y-162R1	
GV 887	Y-181T	
GV 890	Y-162R1	
GN 044	Y-755RS	
880 MJ	Y-157R	
895 MJ	Y-197R	
922 MJ	Y-757RS	
969 MJ	Y-197T	
GV 880	Y-157R	
GV 895	Y-197R	
GV 922	Y-757RS	
GV 969	Y-197T	
GE 102	Y-547AS	DP47
GE 100	Y-607AS	DP50
GE 101	YE14	DP48
GE 105	Y8002AS	DP51
GE 108	Y-609AS	DP49
GE 112	Y9004AS	
GE 110	Y1035AS	DP77
GE 111	Y1036AS	
GE 114	Y9003AS	DP78
GE 118	Y1039AS	DP80
GE 115	Y1002AS	DP57
GE 121 A	Y8001AS	DP58
GE 124	Y1010AS	DP88
GE 127	Y8010AS	
GN 037	Y8005J	DP64
GN 047	YE04	DP40
GN 045	YE12	
GN 053	Y8003J	DP62
GN 056	YE05	DP73
GN 058	YE13	
GN 059	YE07	
GN 063	YE08	

BERU	→ NGK	D-Power
GN 109	Y-519J	DP61
GN 072	CZ258	
CGP 002	CZ104	DP52
GN 116	Y-606J	
GE 121	Y8001AS	DP58
GN 123	CZ267	
141 MJ	Y-207T	
161 MJ	Y-208T	
171 MJ	Y-810	
609 MJ	Y-924J	DP1
613 MJ	Y-924J	DP1
624 MJ	Y-924J	DP1
633 MJ	Y-924J	DP1
950 MJ	Y-732J	DP4

BOSCH	→ NGK	D-Power
0 250 200 014	Y-810	
0 250 200 020	Y-810	
0 250 200 035	Y-302	
0 250 200 037	Y-404	
0 250 200 046	Y-403-1	
0 250 200 049	Y-207T	
0 250 200 051	Y-403T	
0 250 200 052	Y-207T	
0 250 200 053	Y-909R	
0 250 200 054	Y-208T	
0 250 200 055	Y-810	
GLP 063	Y-810	
0 250 200 056	Y-208T	
0 250 200 058	Y-208T	
0 250 200 059	Y-208T	
0 250 200 060	Y-208T	
0 250 200 063	Y-207T	
0 250 200 065	Y-208T	
0 250 200 068	Y-208T	
0 250 200 069	Y-924J	DP1
0 250 200 420	Y-810	
0 250 200 454	Y-208T	
0 250 200 456	Y-208T	
0 250 200 465	Y-208T	
0 250 200 468	Y-208T	
0 250 201 001	Y-924J	DP1
0 250 201 004	Y-918J	DP2
0 250 201 005	Y-924J	DP1
0 250 201 006	Y-924J	DP1
0 250 201 008	Y-924J	DP1
0 250 201 009	Y-924J	DP1
0 250 201 011	Y-918J	DP2
0 250 201 012	Y-909R	
0 250 201 013	Y-924J	DP1
0 250 201 015	Y-918J	DP2
0 250 201 017	Y-907R	

BOSCH	→ NGK	D-Power
GLP 186	Y-907R	
0 250 201 019	Y-924J	DP1
0 250 201 021	Y-918J	DP2
0 250 201 026	Y-916J	DP6
0 250 201 027	Y-924J	DP1
0 250 201 029	Y-913J	
0 250 201 032	Y-918J	DP2
0 250 201 033	Y-924J	DP1
0 250 201 034	Y-909R	
0 250 201 035	Y-930U	DP30
0 250 201 038	Y-925J	DP16
0 250 201 039	Y-924J	DP1
0 250 201 041	Y-916J	DP6
0 250 201 042	Y-924J	DP1
0 250 201 043	Y-913J	
0 250 201 049	Y-937J	
0 250 201 050	Y-933J	DP25
0 250 201 053	Y-939J	DP43
0 250 201 054	Y-925J	DP16
0 250 201 055	Y-916J	DP6
0 250 201 405	Y-924J	DP1
0 250 201 415	Y-918J	DP2
0 250 202 001	Y-910J	DP3
0 250 202 002	Y-739R	
0 250 202 003	Y-115T1	
0 250 202 004	Y-128T	
0 250 202 005	Y-117RS	
0 250 202 006	Y-118T1	
0 250 202 007	Y-107R	
0 250 202 008	Y-306R	
0 250 202 009	Y-732J	DP4
0 250 202 013	Y-204RS	
0 250 202 015	Y-103	
0 250 202 017	Y-112R1	
0 250 202 018	Y-910J	DP3
0 250 202 020	Y-503J	DP10
0 250 202 022	Y-732J	DP4
0 250 202 023	Y-741U	DP20
0 250 202 024	Y-927J	DP19
0 250 202 025	Y-730U	DP17
0 250 202 026	Y-929U	DP41
0 250 202 027	Y-604J	
0 250 202 028	Y-747U	DP26
0 250 202 029	Y-745U	DP11
0 250 202 032	Y-504J	DP24
0 250 202 033	Y-910J	DP3
0 250 202 034	Y-928U	DP29
0 250 202 035	Y-506J	DP7
0 250 202 036	Y-534J	DP36
0 250 202 038	Y1031J	DP71
0 250 202 039	Y-745U	DP11
0 250 202 040	Y-729U	DP34

BOSCH	→ NGK	D-Power
0 250 202 041	Y-746J	DP38
0 250 202 042	Y-748U	DP14
0 250 202 043	Y-523J	DP37
0 250 202 045	Y-745U	DP11
0 250 202 046	Y-741U	DP20
0 250 202 048	Y1005J	DP56
0 250 202 051	Y-146R	
0 250 202 054	Y-118R	
0 250 202 058	Y-147T	
0 250 202 064	Y-755RS	
0 250 202 065	Y-904M1	
0 250 202 069	Y-162R1	
0 250 202 071	Y-181T	
0 250 202 076	Y-197R	
0 250 202 077	Y-705RS	
0 250 202 085	Y-710J	
0 250 202 086	Y-307R	
0 250 202 087	Y-711J	DP28
0 250 202 089	Y-701J	DP39
0 250 202 090	Y1006J	
0 250 202 092	Y-733J	DP13
0 250 202 093	Y-712RS	
0 250 202 094	Y-115T1	
0 250 202 095	Y-532J	
0 250 202 096	Y-118T1	
0 250 202 097	Y-197T	
0 250 202 102	Y-501U	DP31
0 250 202 103	Y-507J	DP32
0 250 202 107	Y-157R	
0 250 202 110	Y-112T	
0 250 202 119	Y-178T	
0 250 202 124	Y1007J	DP59
0 250 202 125	Y-531J	DP44
0 250 202 128	Y-517J	
0 250 202 129	Y-516J	DP12
0 250 202 130	Y-548J	DP75
0 250 202 131	Y-524J	DP27
0 250 202 132	Y1030J	DP70
0 250 202 135	Y1005J	DP56
0 250 202 137	Y-541J	DP42
0 250 202 140	Y-929U	DP41
0 250 202 141	Y-745U	DP11
0 250 202 142	Y-745U	DP11
0 250 202 143	Y-605J	
0 250 203 001	YE07	
0 250 203 002	Y8003J	DP62
0 250 203 004	YE12	
0 250 203 009	Y8005J	DP64
0 250 203 012	YE08	
0 250 204 001	YE04	DP40
0 250 204 002	YE05	DP73
0 250 212 006	Y-749J	



BOSCH	→ NGK	D-Power
0 250 212 009	Y-732J	DP4
0 250 212 011	Y-527J	DP67
0 250 312 001	CZ259	
0 250 312 002	CZ260	
0 250 312 003	Y-603J	DP60
0 250 312 007	CZ257	DP83
0 250 402 001	Y-607AS	DP50
0 250 402 002	Y-547AS	DP47
0 250 402 005	Y-607AS	DP50
0 250 403 001	Y8008AS	DP74
0 250 403 002	YE14	DP48
0 250 403 004	Y8011AS	
0 250 403 007	Y1002AS	DP57
0 250 403 008	Y8002AS	DP51
0 250 403 009	Y1002AS	DP57
0 250 403 010	Y8009AS	
0 250 403 011	Y9003AS	DP78
0 250 403 012	Y1035AS	DP77
0 250 403 013	Y1036AS	
0 250 403 014	Y9001AS	DP72
0 250 403 019	Y8010AS	
0 250 403 021	Y1010AS	DP88
0 250 404 001	Y8001AS	DP58
F 01G 000 00P	Y1012J	DP65
F 01G 004 031	CZ267	
GLP 015	Y-924J	DP1
GLP 002	Y-918J	DP2
GLP 047	Y-909R	
GLP 025	Y-930U	DP30
GLP 001	Y-924J	DP1
GLP 006	Y-916J	DP6
GLP 005	Y-924J	DP1
GLP 037	Y-913J	
GLP 012	Y-937J	
GLP 036	Y-933J	DP25
GLP 045	Y-939J	DP43
GLP 017	Y-925J	DP16
GLP 006	Y-916J	DP6
GLP 010	Y-910J	DP3
GLP 041	Y-739R	
GLP 159	Y-128T	
GLP 167	Y-117RS	
GLP 117	Y-107R	
GLP 096	Y-306R	
GLP 125	Y-103	
GLP 148	Y-112R1	
GLP 004	Y-503J	DP10
GLP 003	Y-732J	DP4
GLP 023	Y-741U	DP20
GLP 020	Y-927J	DP19
GLP 014	Y-730U	DP17
GLP 021	Y-929U	DP41

BOSCH	→ NGK	D-Power
GLP 078	Y-604J	
GLP 032	Y-747U	DP26
GLP 013	Y-504J	DP24
GLP 121	Y-910J	DP3
GLP 026	Y-928U	DP29
GLP 009	Y-506J	DP7
GLP 007	Y-534J	DP36
GLP 109	Y1031J	DP71
GLP 048	Y-729U	DP34
GLP 102	Y-746J	DP38
GLP 019	Y-748U	DP14
GLP 030	Y-523J	DP37
GLP 008	Y-745U	DP11
GLP 033	Y-741U	DP20
GLP 055	Y1005J	DP56
GLP 124	Y-146R	
GLP 116	Y-118R	
GLP 142	Y-147T	
GLP 098	Y-755RS	
GLP 103	Y-904M1	
GLP 138	Y-162R1	
GLP 185	Y-181T	
GLP 136	Y-197R	
GLP 127	Y-705RS	
GLP 072	Y-710J	
GLP 046	Y-711J	DP28
GLP 038	Y-701J	DP39
GLP 054	Y-733J	DP13
GLP 049	Y-712RS	
GLP 034	Y-115T1	
GLP 074	Y-532J	
GLP 042	Y-118T1	
GLP 132	Y-197T	
GLP 031	Y-501U	DP31
GLP 040	Y-507J	DP32
GLP 169	Y-157R	
GLP 155	Y-112T	
GLP 152	Y-178T	
GLP 137	Y1007J	DP59
GLP 101	Y-531J	DP44
GLP 057	Y-517J	
GLP 011	Y-516J	DP12
GLP 051	Y-548J	DP75
GLP 024	Y-524J	DP27
GLP 066	Y1030J	DP70
GLP 111	Y1005J	DP56
GLP 092	Y-541J	DP42
GLP 021	Y-929U	DP41
GLP 022	Y-745U	DP11
GLP 008	Y-745U	DP11
GLP 225	Y-605J	
GLP 043	YE07	

BOSCH	→ NGK	D-Power
GLP 016	Y8003J	DP62
GLP 115	YE12	
GLP 205	Y8005J	DP64
GLP 210	YE08	
GLP 059	YE04	DP40
GLP 094	YE05	DP73
GLP 203	Y-749J	
GLP 224	Y-732J	DP4
GLP 108	CZ259	
GLP 105	CZ260	
GLP 035	Y-603J	DP60
GLP 039	CZ257	DP83
GLP 070	Y-547AS	DP47
GLP 050	Y-607AS	DP50
GLP 144	Y8008AS	DP74
GLP 093	YE14	DP48
GLP 201	Y8011AS	
GLP 194	Y1002AS	DP57
GLP 202	Y8002AS	DP51
GLP 179	Y8009AS	
GLP 196	Y9003AS	DP78
GLP 221	Y1035AS	DP77
GLP 222	Y1036AS	
GLP 253	Y8010AS	
GLP 237	Y1010AS	DP88
GLP 212	Y1012J	DP65
GLP 251	CZ267	

BRISK	→ NGK	D-Power
21 N 21	Y-208T	
21 N 22	Y-208T	
21 N 51	Y-909R	
21 R 01	Y-918J	DP2
21 R 02	Y-907R	
21 R 06	Y-918J	DP2
21 R 21	Y-924J	DP1
21 R 22	Y-924J	DP1
21 R 23	Y-924J	DP1
21 R 26	Y-913J	
21 R 51	Y-909R	
21 R 71	Y-910J	DP3

CHAMPION	→ NGK	D-Power
CH 60	Y-207T	
CH 63	Y-208T	
CH 65	Y-810	
CH 68	Y-523J	DP37
CH 69	Y-918J	DP2
CH 70	Y-909R	
CH 79	Y-907R	
CH 78	Y-208T	

CHAMPION	→ NGK	D-Power
CH 88	Y-924J	DP1
CH 90	Y-739R	
CH 94	Y-115T1	
CH 95	Y-146R	
CH 97	Y-107R	
CH 98	Y-117RS	
CH 102	Y-112M1	
CH 103	Y-118T1	
CH 104	Y-197R	
CH 121	Y-118T1	
CH 137	Y-924J	DP1
CH 147	Y-910J	DP3
CH 154	Y-715R	
CH 158	Y-711J	DP28
CH 159	Y-924J	DP1
CH 160	Y-918J	DP2
CH 161	Y-755RS	
CH 162	Y-707RS	
CH 163	Y-924J	DP1
CH 166	Y-747U	DP26
CH 167	Y-928U	DP29
CH 169	Y-730U	DP17
CH 170	Y-504J	DP24
CH 171	Y-732J	DP4
CH 172	Y-740U	DP22
CH 173	Y-913J	
CH 174	Y-924J	DP1
CH 175	Y-930U	DP30
CH 176	Y-916J	DP6
CH 177	Y-925J	DP16
CH 178	Y-729U	DP34
CH 179	Y-933J	DP25
CH 181	Y-741U	DP20
CH 184	Y-732J	DP4
CH 185	Y-503J	DP10
CH 189	Y-924J	DP1
CH 196	Y-524J	DP27
CH 203	Y-507J	DP32
CH 204	Y-929U	DP41
CH 205	Y-937J	
CH 206	Y-927J	DP19
CH 207	Y-748U	DP14
CH 208	Y-738U	
CH 215	Y-501U	DP31
CH 216	Y-502R	
CH 217	Y-506J	DP7
CH 218	Y-745U	DP11
CH 219	Y-746J	DP38
CH 221	Y-115T1	
CH 223	Y8003J	DP62
CH 224	YE07	
CH 263	Y1007J	DP59



CHAMPION	→ NGK	D-Power
CH 268	Y1005J	DP56
CH 600	CZ260	
CH 601	Y-603J	DP60
CH 602	CZ257	DP83
CHRYSLER	→ NGK	D-Power
05066 840 AA	Y1031J	DP71
5175 756 AA	Y8002AS	DP51
68029497 AA	Y8011AS	
DENSO	→ NGK	D-Power
067100-1042	Y-402-2	
067100-1043	Y-452-1	
067100-1070	Y-176	
067100-1071	Y-176	
067100-1090	Y-108	
067100-1120	Y-178	
067100-1130	Y-128	
DG-226	Y-178	
DG-227	Y-128	
067100-1161	Y-178T	
067100-1170	Y-128T	
067100-1171	Y-128T	
067100-1270	Y-118T1	
067100-1330	Y-147T	
067100-1340	Y-197T	
067100-1350	Y-128T	
067100-1360	Y-178T	
067100-1370	Y-118R	
067100-1430	Y-146R	
067100-1460	Y-197R	
067100-1530	Y-146R	
067100-1630	Y-118T1	
067100-1690	Y-703R	
067100-1710	Y-715R	
067100-1860	Y-532J	
	Y-178T	
	Y-128T	
	Y-128T	
	Y-118T1	
DG-232	Y-147T	
DG-233	Y-197T	
DG-234	Y-128T	
DG-235	Y-178T	
DG-215	Y-118R	
DG-223	Y-146R	
DG-222	Y-197R	
	Y-146R	
DG-221	Y-118T1	
DG-216	Y-703R	
DG-211	Y-715R	

DENSO	→ NGK	D-Power
DG-214	Y-532J	
DG-001	Y-924J	DP1
DG-003	Y-503J	DP10
DG-004	Y-910J	DP3
DG-005	Y-732J	DP4
DG-006	Y-913J	
DG-007	Y-937J	
DG-008	Y-506J	DP7
DG-009	Y-927J	DP19
DG-010	Y-916J	DP6
DG-012	Y-918J	DP2
DG-101	Y-740U	DP22
DG-102	Y-928U	DP29
DG-103	Y-933J	DP25
DG-105	Y-115T1	
DG-106	Y-925J	DP16
DG-108	Y-904M1	
DG-109	Y-741U	DP20
DG-110	Y-929U	DP41
DG-111	Y-502R	
DG-112	Y-516J	DP12
DG-113	YE04	DP40
DG-114	Y-107R	
DG-115	Y-729U	DP34
DG-116	Y-504J	DP24
DG-117	Y-925J	DP16
DG-118	Y-748U	DP14
DG-119	Y-930U	DP30
DG-120	Y-707RS	
DG-121	Y-524J	DP27
DG-122	Y-534J	DP36
DG-123	Y-907R	
DG-124	Y-710J	
DG-126	Y-517J	
DG-127	Y-747U	DP26
DG-129	Y-939J	DP43
DG-130	Y-548J	DP75
DG-133	Y-604J	
DG-137	Y-712RS	
DG-140	YE12	
DG-142	Y-523J	DP37
DG-144	Y-732J	DP4
DG-145	Y-507J	DP32
DG-146	Y-701J	DP39
DG-155	Y-746J	DP38
DG-157	Y-705RS	
DG-161	Y-924J	DP1
DG-170	YE07	
DG-171	Y8003J	DP62
DG-172	Y-722JS	
DG-173	Y-749J	
DG-176	Y1031J	DP71

DENSO	→ NGK	D-Power
DG-177	Y-607AS	DP50
DG-178	Y-547AS	DP47
DG-180	YE05	DP73
DG-181	Y1005J	DP56
DG-182	Y-605J	
DG-184	Y-543J	DP46
DG-185	Y-910J	DP3
DG-186	Y1038J	
DG-187	Y1007J	DP59
DG-188	Y-536J	DP81
DG-189	Y-508J	
DG-190	YE14	DP48
DG-193	Y1002AS	DP57
DG-194	Y8002AS	DP51
DG-195	Y8005J	DP64
DG-196	Y1030J	DP70
DG-197	Y-519J	DP61
DG-202	Y-909R	
DG-217	Y-531J	DP44
DG-240	Y-542J	DP45
DG-245	Y-531J	DP44
DG-300	Y-603J	DP60
DG-301	CZ257	DP83
DG-304	CZ260	
DG-305	Y1013J	DP63
DG-306	CZ256	
DG-307	CZ259	
DG-502	Y-529J	
DG-615	Y-606J	
DG-633	Y8011AS	

FORD	→ NGK	D-Power
1148 105	YE04	DP40
1313 809	Y1005J	DP56
1427 905	YE08	
1447 128	YE05	DP73
1459 460	Y-548J	DP75
1473 356	Y1005J	DP56
1542 845	Y8003J	DP62
1682 276	Y8001AS	DP58
4025 139	Y-701J	DP39
1717 631	Y1045AS	DP89
2S6Q-6M090-AA	YE04	DP40
3M5Q-6M090-AB	Y1005J	DP56
6G9Q-6M090-AA	YE08	
2S6Q-6M090-BB	YE05	DP73
7C16-6M090-AA	Y-548J	DP75
3M5Q-6M090-AC	Y1005J	DP56
9S51-6M090-AA	Y8003J	DP62
AV6Q-6M090-BA	Y8001AS	DP58
XM341-2A342-BA	Y-701J	DP39
BK3Q-6M090-AB	Y1045AS	DP89

FORD	→ NGK	D-Power
2S6Q-6M090-BA	YE05	DP73
BS51-6M090-AA	Y9001AS	DP72

MAGNETI MARELLI	→ NGK	D-Power
061 830 024 304	Y-918J	DP2
061 830 025 304	Y-924J	DP1
061 830 078 304	Y-924J	DP1
UX 1 A	Y-918J	DP2
UX 2 A	Y-924J	DP1
UX 4 A	Y-924J	DP1
TIX 1 A	Y-207T	
TIX 2 A	Y-208T	
TIX 4 A	Y-208T	
TIX 6 A	Y-208T	

MOTORCRAFT	→ NGK	D-Power
96FF6-M090-CA	Y-937J	
XS4U-6M090-AB	Y-524J	DP27
XS7U-6M090-BA	Y-548J	DP75
V95DD-6M090-AA	Y-741U	DP20
10 56 857	Y-937J	
10 79 401	Y-524J	DP27
10 96 527	Y-548J	DP75
16 90 048	Y-741U	DP20
32 52 725	Y-107R	
50 23 372	Y-208T	
50 31 006	Y-924J	DP1
61 32 246	Y-907R	
84FF6-M090-B2A	Y-907R	
61 54 593	Y-924J	DP1
70 88 988	Y-910J	DP3
93FF6-M090-AA	Y-910J	DP3
EZD 1	Y-810	
EZD 5	Y-924J	DP1
EZD 10	Y-918J	DP2
EZD 18	Y-115T1	
EZD 19	Y-128T	
EZD 20	Y-117RS	
EZD 21	Y-118T1	
EZD 22	Y-107T	
EZD 30	Y-924J	DP1
EZD 40	YE04	DP40
EZD 41	Y-504J	DP24
84BB6-M090-AA	Y-924J	DP1
V94DX-6M090-AA	Y-924J	DP1

NISSAN	→ NGK	D-Power
11065-00Q0A	Y-517J	
11065-00Q0E	Y1035AS	DP77
11065-00Q0H	Y1010AS	DP88
11065-00Q0L	Y1010AS	DP88



NISSAN	→ NGK	D-Power
11065-00QAG	Y-732J	DP4
11065-02T00	Y-955RS	
11065-0W801	CZ261	
11065-10G00	Y-705RS	
11065-10T01	Y-757RS	
11065-16A05	Y-117RS	
11065-16A15	Y-117RS	
11065-1749R	Y1010AS	DP88
11065-2TB0A	Y-519J	DP61
11065-2W202	CZ258	
11065-31N00	Y-712RS	
11065-31W00	Y-112T	
11065-31W01	Y-112T	
11065-31W02	Y-112TS	
11065-34W00	Y-112M1	
11065-37506	Y-103	
11065-37507	Y-103	
11065-43G01	Y-707RS	
11065-57J00	CZ260	
11065-5C900	CZ260	
11065-63G00-GW	Y-707RS	
11065-65N01	CZ261	
11065-7C000	Y-530J	
11065-9C600	Y-712RS	
11065-AD200	Y-519J	DP61
11065-AD201	Y-519J	DP61
11065-AD220	Y-519J	DP61
11065-C8600	Y-755RS	
11065-DB000	Y-522J	
11065-G2400	Y-712RS	
11065-G2460	Y-712RS	
11065-G5501	CZ259	
11065-HC200	Y-701J	DP39
11065-HC251	Y-721RS	
11065-J2000	Y-202	
11065-J5501	Y-202-2	
11065-J5502	Y-202-2	
11065-J5570	Y-222T	
11065-MA70A	Y-538J	
11065-MA70A-SG	Y-538J	
11065-OW801	CZ261	
11065-T3400	Y-177-1	
11065-T3401	Y-177-1	
11065-T3470	Y-181T	
11065-T8200	Y-112R1	
11065-T8201	Y-162R1	
11065-T8202	Y-112R1	
11065-T8203	Y-162R1	
11065-T9000	Y-272R1	
11065-T9001	Y-272R1	
11065-V7202	CX51	
11065-V7203	CZ51	

NISSAN	→ NGK	D-Power
11065-Y1400	Y-103-1	
11065-Y1401	Y-103-1	
11065-Y1402	Y-103-2	
11065-Y1403	Y-103-2	
11065-Y1404	Y-103-2	
11065-Z5000	Y-252	
RFJ5-18-601	Y-701J	DP39
09900-F8Q01	Y-516J	DP12
09900-RF001	Y-701J	DP39
18550-79J50	Y1030J	DP70
18550-79J80	Y9003AS	DP78
18550-79J81	Y9003AS	DP78
18550-80KA0	Y1036AS	

VOLVO	→ NGK	D-Power
3072 5069	Y1005J	DP56
3121 6248	YE04	DP40
8631 607	YE12	
8653 698	Y1005J	DP56
8653 880	Y8008AS	DP74

YANMAR	→ NGK	D-Power
124970-77800	Y-116V	
129155-77800	Y-702R	
129155-77801	Y-702U	
129331-77800	Y-110V	
129795-77800	Y-103V	
1C1015-66250	Y-715R	

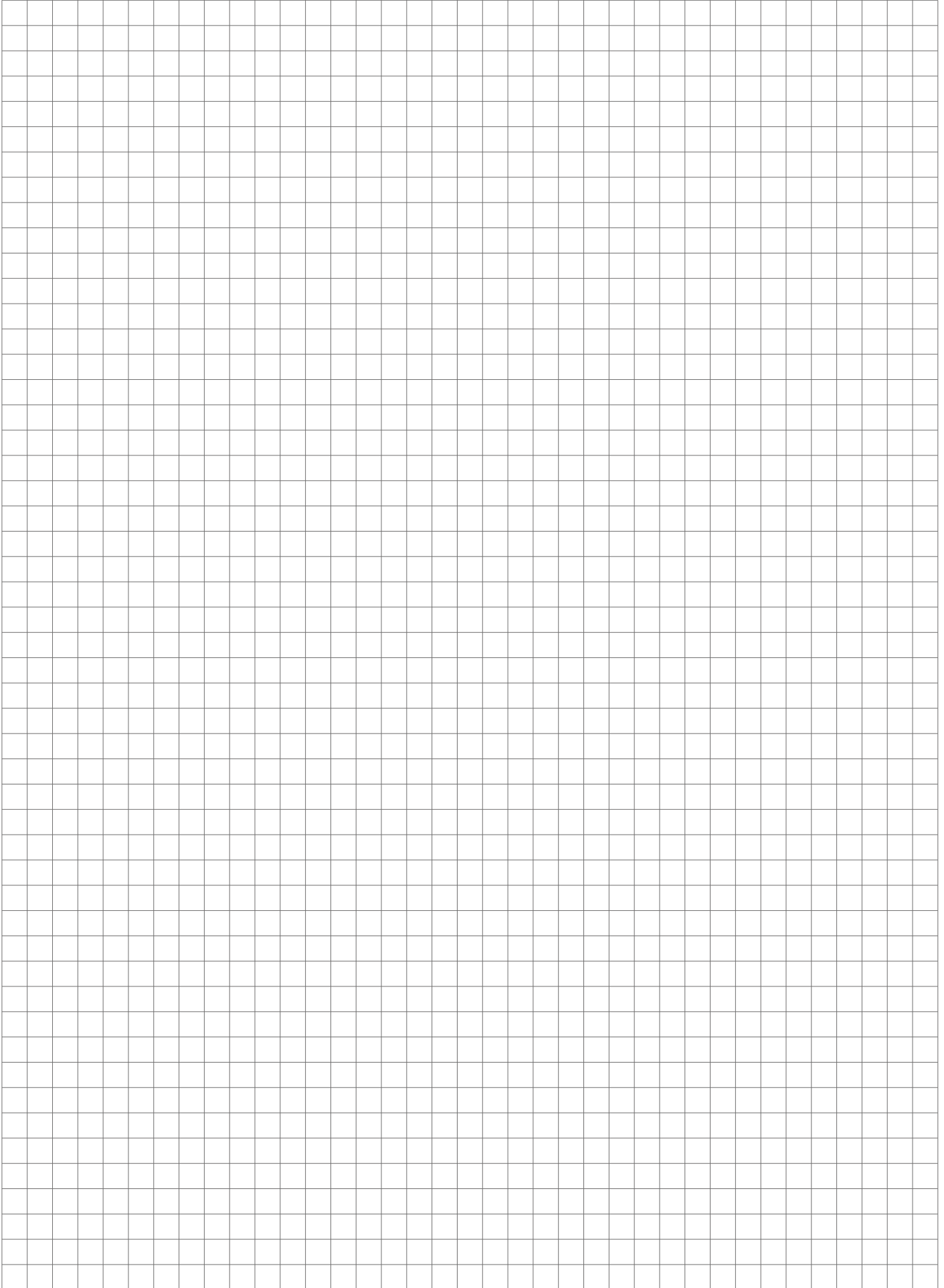

DISCONTINUED PRODUCTS



IGNITION
PARTS



A-6	AB-6
A-7	AB-7
A-8	AB-8
A-8F	A8FS
A-9F	A9FS
APR5FS-11	APR5FS
B10EGP	R7376-10
B10EGV	BR10EIX
B10EV	BR10EIX
B10EVX	BR10EIX
B10H	B10HS
B10HN	R5525-10
B10HP	R5530-10
B10HV	BR10HIX
B10HVX	BR10HIX
B11EGV	BR10EIX
B11EN	BR10EIX
B11HN	R5525-11
B11HP	R5525-11
B5ES-11	B5ES
B6EB-L-11	BR6ES
B6EFS	BR6EF
B6HV	BR6HIX
B6HVX	BR6HIX
B7EB	BR7ES
B7EB-11	BUR7EB-11
B7ET	BR7ET
B7EV	BR7EIX
B7EVX	BR7EIX
B7HV	BR7HIX
B7HVX	BR7HIX
B8EGP	BR8EIX
B8EGV	BR8EIX
B8EM	BR8EM
B8EMV	BR8ET
B8EN	BR8EIX
B8ES-11	B8ES
B8ET	BR8ET
B8EV	BR8EIX
B8EVX	BR8EIX
B8HN	R5525-8
B8HV	BR8HIX
B8HVX	BR8HIX
B95EGV	BR10EIX
B9EGP	BR9EIX
B9EGV	BR9EIX
B9EN	BR9EIX
B9EV	BR9EIX
B9EVX	BR9EIX
B9HCV	BR9HIX
B9HN	BR9HIX
B9HP	R5530-9
B9HV	BR9HIX

B9HVX	BR9HIX
BCP4ES	BCPR4ES-11
BCP5E-11	BCPR5E-11
BCP5EV	BCPR5EIX
BCP5EV-11	BCPR5EIX-11
BCP5EVX	BCPR5EIX
BCP5EVX-11	BCPR5EIX-11
BCP5EY-11	BCPR5EY-11
BCP6E-11	BKR6E-11
BCP6EV	BCP6EVX
BCP6EV-11	BCPR6EIX-11
BCP6EVX-11	BCPR6EIX-11
BCP7E	BCPR7E
BCP7EV	BCPR7EIX
BCP7EVX	BCPR7EIX
BCPR5EP-11	BCPR5EIX-11
BCPR5EP-13	BCPR5EIX-11
BCPR5EVX-11	BCPR5EIX-11
BCPR6EP-13	BCPR6EIX-11
BCPR6EP-N-11	BCPR6EIX-11
BCPR6ER	BKR6EK
BCPR6EVX-11	BCPR6EIX-11
BCPR7ER	BKR6EK
BCPR7EVX-11	BKR7EIX-11
BCPR7EY	BCPR7E
BK5EKU	BKR5EKU
BK7EKU	BKR7EKU
BKR5EVX	BKR5EIX
BKR5EVX-11	BKR5EIX-11
BKR5EVXA-13	PFR5G-13E
BKR6EIX-LPG	LPG1
BKR6EVX	BKR6EIX
BKR6EVXA-11	PFR6G-13E
BKR6EVXA-13	PFR6G-13E
BKR7EVX	BKR7EIX
BKR7EVX-11	BKR7EIX-11
BP10EV	BPR10EIX
BP4EFS	TR4IX
BP4ES-13	BPR4ES-13
BP5EA	BP4EY
BP5EA-11	BP4EY-11
BP5EA-L	BP5EY
BP5EA-L-11	BP5EY-11
BP5EJ	BPR5EJ
BP5EKN	BPR5EY
BP5EV	BPR5EIX
BP5EVX	BPR5EIX
BP5EVX-11	BPR5EIX-11
BP6EA	BP6EY
BP6EA-11	BP6EY-11
BP6EF-13	BPR6EF-13
BP6EK	BPR6EK-A
BP6EK-A	BPR6EK-A



BP6EKA-V	BPR6EK-A
BP6EKN	BPR6EKN
BP6EV	BPR6EIX
BP6EVX	BPR6EIX
BP6EVX-11	BPR6EIX-11
BP6HV	BPR6HIX
BP6HVX	BPR6HIX
BP7E	BPR7E
BP7EKN	BPR7EKN
BP7EV	BPR7EIX
BP7EVX	BPR7EIX
BP7EY-11	BPR7EY-11
BP7HV	BPR7HIX
BP7HVX	BPR7HIX
BP8ES-11	BP8ES
BP8EV	BPR8EIX
BP8EVX	BPR8EIX
BP8FS	R5674-8
BP8HSA	BPR8HSA
BP8HVX	BPR8HIX
BP9EV	BPR9EIX
BPR-2E	BPR2ES
BPR4EVX	GR4IX
BPR4S	BP-4
BPR4S-15	BP-4
BPR5EA	BPR5EY
BPR5EA-11	BPR5EY-11
BPR5EA-L	BPR5EY
BPR5EF-13	BPR5EFS-13
BPR5EFVX	TR5IX
BPR5EK-A	BPR5EIX-11
BPR5EP-13	BPR5EP-11
BPR5EV	BPR5EIX
BPR5EVX	BPR5EIX
BPR5EVX-11	BPR5EIX-11
BPR5S	BP5S
BPR6EA	BPR5EY
BPR6EV	BPR6EIX
BPR6EVX	BPR6EIX
BPR6FS-15	BPR6FS
BPR6HVX	BPR6HIX
BPR6S	BP6S
BPR7EVX	BPR7EIX
BPR7HVX	BPR7HIX
BPR8EVX	BPR8EIX
BPR9EVX	BPR9EIX
BR10ECMVX	BR10ECMIX
BR10EV	BR10EIX
BR5EB	BR5ES
BR5EB-11	BUR5EB-11
BR5ES-11	BR5ES
BR5FS-15	BR5FS
BR6EB	BR6ES

BR6EB-11	BUR6EB-11
BR7EB	BR7ES
BR7EB-11	BUR7EB-11
BR7ES-11	BR7ES
BR7EVX	BR7EIX
BR8ECMVX	BR8ECMIX
BR8EV	BR8EIX
BR8EVX	BR8EIX
BR8HV	BR8HIX
BR8HVX	BR8HIX
BR9ECMVX	BR9ECMIX
BR9EV	BR9EIX
BR9EVX	BR9EIX
BU6EA-11	BUR6EA-11
BU6EB-11	BUR6EB-11
BU7EA-11	BUR7EA-11
BUEW	BUE
BUR5EBVX-11	BUR5EB-11
BZ8ES	BR8ES
C10H	R0161-10
C4HA	CR4HSA
C6H	C6HSA
C6M	C6HSA
C7EH-9	CR7EH-9
C7HV	CR7HIX
C7HVX	CR7HIX
C8EHVX-9	CR8EHIX-9
C8EVX	CR8EIX
C8HV	CR8HIX
C9EHVX-9	CR9EHIX-9
C9EVX	CR9EIX
C9H	C8HSA
CR8EHVX-9	CR8EHIX-9
CR8EVX	CR8EIX
CR9EHVX-9	CR9EHIX-9
CR9EVX	CR9EIX
D12E	R2349-11
D-4H	DR4HS
D6ES	D6EA
D6HS	D6HA
D6HV	D6HA
D7EV	DR7EIX
D7EVX	DR7EIX
D8EV	DR8EIX
D8EVX	DR8EIX
D8HS	D8HA
D8HV	D8HA
D9EV	DR9EIX
D9EVX	DR9EIX
DCP8E	DCPR8E
DCP8EVX	DCPR8EIX
DCPR7E-N	DCPR7E-N-10
DCPR8EVX	DCPR8EIX



DCPR9EVX	DCPR9EIX
DIMR8B10	DIMR8A10
DP5EA-9	DPR5EA-9
DP7Z	DPR7Z
DP8EV-9	DPR8EIX-9
DP8EVX-9	DPR8EIX-9
DP9EV-9	DPR9EIX-9
DP9EVX-9	DPR9EIX-9
DPR7EV-9	DPR7EIX-9
DPR7EVX-9	DPR7EIX-9
DPR8EV-9	DPR8EIX-9
DPR8EVX-9	DPR8EIX-9
DPR9EV-9	DPR9EIX-9
DPR9EVX-9	DPR9EIX-9
DR8EVX	DR8EIX
DR9EVX	DR9EIX
FR2A-D	FR2B-D
GR4VX	GR4
GR5VX	GR5IX
IFR7G-11K	IFR7G-11KS
IKR9F8	IKR9J8
ILKAR6C10	ILKAR7C10
ILZKBR7A-8G	ILZKBR7B8DG
ITR5F13	TR5AI-13
JR10A	JR10B
JR9A	JR9B
LKR9CI-8	ILKR9G8
PFR4C-11	PFR4G-11
PFR5B	PFR5B-9
PFR6C-11	PFR6G-11
PFR6K-11	PFR6A-11
PGR6B	PGR6A-11
PLZKBR7A-G	PLZKBR7B8DG
PZFR6B	IZFR6B
PZFR6R8EG	SIZFR6B8EG
R0045A-10	R0045Q-10
R0045A-11	R0045J-11
R0045J-10	R0045Q-10
R015-10	R0373A-10
R015-8	CR8EIX
R015-9	R0373A-10
R015-95	R0373A-10
R016-10	R0373A-10
R016-105	R0373A-9
R016-11	R0373A-11
R016-8	CR8EIX
R016-9	R0373A-10
R016E-11P	R0373A-11
R017-10	R0373A-10
R017-11	R0373A-11
R017-9	R0373A-9
R017-S11	R0373A-11
R0256K-11	R0373A-11

R0256R-10	R0373A-10
R2097-11P	R2525-10
R216-10	R2525-10
R216-11	R2525-10
R216-12	R2349-11
R216-9	R2525-9
R217-10	R2525-10
R217-11	R2525-10
R217-12	R2349-11
R217-9	R2525-9
R2198-12P	R2349-11
R2270-11	R2349-11
R2270-9	R2349-9
R2430-10	R2349-10
R2430-9	R2349-9
R2525-11	R2349-11
R4118M-10	R4118S-10
R4118-M8	R4118S-8
R4118-M9	BR9EIX
R4118S-9	BR9EIX
R4304A-9	BPR9EIX
R4339-9	B9EG
R4452D-10	R7376-10
R4452D-105	B105EGP
R4452D-11	B11EGP
R4452D-8	BR8EIX
R4452D-85	B85EGP
R4452D-9	BR9EIX
R4452D-95	B95EGP
R4468A-11	R6725-11
R4468A-115	R6725-115
R4630A-10	R7376-10
R4630A-105	R7376-10
R4630A-11	R7376-10
R4630A-8	R7376-8
R4630A-9	R7376-9
R5184-11	R7282-11
R5300A-105	R7282-105
R5300A-11	R7282-11
R5300A-9	R7282-9
R5300N-105	R7282-105
R5400-10	R7435-10
R5400-7	BCPR7EIX
R5400-8	R7435-8
R5400-9	R7435-9
R5525-7	BR7HIX
R5525-9	BR9HIX
R5530-8	BR8HIX
R5540-10	R5540F-10
R5540F-11	R7282-11
R5649-10	R6712-10
R5649-9	R6712-9
R5671-8	R5671A-8



R5671-9	R5671A-9
R5672-8	R5672A-8
R5672-9	R5672A-9
R5686-10	R7436-10
R5686-11	R7436-10
R5686-8	R7436-8
R5686-9	R7436-9
R5687-10	R7436-10
R5687-8	R7436-8
R5687-9	R7436-9
R5796-8	R7436-8
R5830-10	R7436-10
R5830-9	R7436-9
R6021E-85	R6918B-9
R6021E-9	R6918B-9
R6061-8	BR8ECMIX
R6120-10	R7282-10
R6120-105	R7282-105
R6120-11	R7282-11
R6120A-105	R7282A-105
R6120A-11	R7282A-11
R6120C-105	R7282-105
R6120C-11	R7282-11
R6120M-105	R7282-105
R6120M-11	R7429A-10
R6179A-105P	R7282-105
R6205-9	R7433-9
R6242-10	R7434-10
R6252E-8	R7376-8
R6252E-9	R7376-9
R6254E-8	R6254E-9
R6255-9	R7433-9
R6326-9	R7433-9
R6385-105P	R7376-10
R6385-10P	R7376-10
R6385-11P	R7376-10
R6385-8P	R7376-8
R6385-9P	R7376-9
R6711-9	R6601-9
R6888A-8	R7433-8
R7112-7	IRIWAY7
R7112-8	R7433-8
R7112-9	R7433-9
R7113-9	R7433-9
R7114-9	R7433-9
R7115-10	R7433-10
R7115-8	R7433-8
R7115-9	R7433-9
R7116-10	R7434-10
R7116-8	R7434-8
R7116-9	R7434-9
R7117-10	R7434-10
R7117-8	R7434-8

R7117-9	R7434-9
R7118-10	R7434-10
R7118-8	R7434-8
R7119-8	R7434-8
R7119-9	R7434-9
R7232-7	BCPR7EIX
R7232-8	R7435-8
R7232-9	R7435-9
R7234-10	R7436-10
R7234-8	R7436-8
R7234-9	R7436-9
R7235-10	R7435-10
R7235-8	R7435-8
R7235-9	R7435-9
R7236-9	R7436-9
R7238-10	R7436-10
R7238-9	R7436-9
R7279-10	R7434-10
R7279-9	R7434-9
R7282C-105	R7282-105
R7282C-11	R7282-11
R7282M-105	R7282-105
R7282M-11	R7429A-10
R8108-10	R8108A-10
R8108-95	R8108A-10
RE8A-L	RE8C-L
SR5	TR5-1
TR4-2	TR4
TR4VX	TR4IX
TR5-1VX	TR5-1IX
TR55-1VX	TR55-1IX
TR55GP	TR55IX
TR55VX	TR55IX
UR40	UR45
UR45VX	UR45IX
UR4VX	UR4IX
UR55VX	UR55IX
UR5VX	UR5IX
UR6VX	UR6IX
WR5GP	WR5IX
WR5VX	WR5IX
XR40	XR45
XR45VX	XR45IX
XR4VX	XR4IX
XR5VX	XR5IX
YR55VX	YR55IX
YR5VX	YR5IX
ZFR7A-11	ZFR7F-11



GB

This catalogue supersedes all previous catalogs. NGK SPARK PLUG EUROPE GmbH has made its best effort to ensure an accurate information, based on information available at the time of the compilation of the catalog. This catalog is made for information only. NGK SPARK PLUG EUROPE GmbH will not accept liability for any inaccuracy. Product linkage to vehicles or tools applications from this publication are considered under normal condition of use, fitted by a professional and for vehicles registered in Europe. For all different usage or post equipment, the responsibility of NGK cannot be engaged. All ordered products are subject to valid terms and conditions supplied by NGK SPARK PLUG EUROPE GmbH.

The cross reference list (page 293–390) is furnished as a guide. Due to differences in design, materials, etc., products by various manufacturers may not match. See therefore our recommendation for the proper use of the acquired product. Pictures, diagrams and drawings in this publication are not contractual. The property of the pictures, diagrams, drawings and other graphic elements and data belong to NGK SPARK PLUG EUROPE GmbH exclusively. Reproduction of this publication, partial or total, is strictly prohibited without a prior written authorization of NGK SPARK PLUG EUROPE GmbH.

DE

Mit Veröffentlichung dieser Ausgabe verlieren alle vorhergehenden Ausgaben ihre Gültigkeit. Dieser Katalog wurde, basierend auf den zum Zeitpunkt der Erstellung des Katalogs verfügbaren Informationen, von der NGK SPARK PLUG EUROPE GmbH nach bestmöglichem Wissen erstellt. Dieser Katalog dient ausschließlich zu Informationszwecken. Die NGK SPARK PLUG EUROPE GmbH übernimmt keine Haftung für Druckfehler, Irrtümer oder sonstige fehlerhafte Informationen. Alle in diesem Katalog erwähnten Produkt-Zuordnungen zu Fahrzeugen oder Werkzeugen gelten für einen Einsatz unter normalen Bedingungen, den Einbau durch einen Fachmann sowie Fahrzeuge, die innerhalb der EU zugelassen sind. Die NGK SPARK PLUG EUROPE GmbH kann nicht für andere Nutzungszwecke oder Nachrüstungen jedweder Art haftbar gemacht werden. Alle bestellten Produkte unterliegen den geltenden Geschäftsbedingungen der NGK SPARK PLUG EUROPE GmbH.

Die Referenzliste (Seite 293–390) dient nur zur Information. Bedingt durch Unterschiede hinsichtlich Konstruktion, Werkstoffen usw. können Produkte verschiedener Hersteller nicht zusammenpassen. Siehe daher unsere Empfehlung für die richtige Anwendung des erworbenen Produkts. Die in diesem Katalog abgebildeten Bilder, Diagramme und Zeichnungen sind nicht Vertragsbestandteil. Alle Bilder, Diagramme, Zeichnungen sowie andere graphische Elemente und Daten sind exklusives

Eigentum der NGK SPARK PLUG EUROPE GmbH. Jedwede Vervielfältigung dieses Katalogs, auch auszugsweise, ohne vorherige schriftliche Genehmigung durch die NGK SPARK PLUG EUROPE GmbH ist strengstens untersagt.

FR

NGK SPARK PLUG EUROPE GmbH a réalisé tous les efforts nécessaires pour assurer l'exactitude des informations sur la base des informations disponibles au moment de la compilation du catalogue. Ce catalogue a été élaboré à titre informatif uniquement. NGK SPARK PLUG EUROPE GmbH n'acceptera aucune responsabilité en cas d'inexactitude. Les liens de produits avec des véhicules ou des outils dans cette publication sont considérés dans des conditions normales d'utilisation, installés par un professionnel et pour les véhicules immatriculés en Europe. Pour toute utilisation différente ou équipement de conversion, la responsabilité de NGK ne peut pas être engagée. Tous les produits commandés sont soumis à des termes et conditions valides fournis par NGK SPARK PLUG EUROPE GmbH. Les images, diagrammes et dessins de cette publication ne sont pas contractuels. Ce tableau de comparaison (page 293–390) est donné à titre indicatif. De par leurs différences de conceptions, matériaux, etc., les pièces produites par les différents fabricants n'ont pas exactement les mêmes caractéristiques. Se reporter au tableau d'affectations NGK pour déterminer la référence adaptée à l'application. Les images, les diagrammes, les dessins et autres éléments graphiques et données appartiennent à NGK SPARK PLUG EUROPE GmbH exclusivement. La reproduction de cette publication, partielle ou totale, est strictement interdite sans autorisation écrite préalable de NGK SPARK PLUG EUROPE GmbH.

IT

Il presente catalogo sostituisce tutti i precedenti. NGK SPARK PLUG EUROPE GmbH ha posto la massima attenzione per offrire informazioni accurate, basate sui dati disponibili al momento della compilazione del catalogo. Il presente catalogo ha esclusivamente scopo informativo. NGK SPARK PLUG EUROPE GmbH non si assume nessuna responsabilità per eventuali imprecisioni. Si considera che i veicoli a cui si riferisce questa pubblicazione si trovino in condizioni di utilizzo normali, siano stati montati da un professionista e su veicoli immatricolati in Europa. Per qualsiasi utilizzo o per attrezzature montate successivamente, NGK non si assume nessuna responsabilità. Tutti i prodotti ordinati sono soggetti ai termini e alle condizioni forniti da NGK SPARK PLUG EUROPE GmbH. Le tabelle comparative (pag. 293–390) vengono fornite a scopo di guida. A causa della differenza nel design, materiale, ecc.. le

candele d'accensione prodotte da un altro costruttore potrebbero non corrispondere. Attenersi alle nostre raccomandazioni per il corretto utilizzo del prodotto. Le immagini, i grafici e i disegni presenti in questa pubblicazione non sono contrattuali. Le immagini, dei grafici, i disegni e gli altri elementi e dati sono di proprietà esclusiva di NGK SPARK PLUG EUROPE GmbH. La riproduzione della presente pubblicazione, parziale o totale, è strettamente proibita senza la preventiva autorizzazione scritta di NGK SPARK PLUG EUROPE GmbH.

ES

Este catálogo reemplaza a todos los catálogos anteriores. NGK SPARK PLUG EUROPE GmbH ha hecho todo lo posible para garantizar que la información sea correcta, basándose en la información disponible en el momento de la redacción del catálogo. Este catálogo se ha hecho con propósitos meramente informativos. NGK SPARK PLUG EUROPE GmbH no acepta ninguna responsabilidad por los posibles errores. Se considera que la utilización de los productos en vehículos o aplicaciones de herramientas de esta publicación se realiza en condiciones de uso normales, montados por un profesional y en vehículos matriculados en Europa. Para todos los otros usos o equipamiento a posteriori, NGK no puede considerarse responsable. Todos los productos pedidos están sujetos a los términos y condiciones válidos de NGK SPARK PLUG EUROPE GmbH. Las imágenes, los diagramas y los dibujos de esta publicación no tienen valor contractual. La lista de referencias cruzadas (páginas 293–390) le servirá como guía. Debido a la diferencia en el diseño, materiales, etc., las bobinas producidas por otro fabricante pueden no coincidir. Siga nuestras recomendaciones para el uso adecuado del producto. Las imágenes, los diagramas, los dibujos, los otros elementos gráficos y los datos son propiedad exclusiva de NGK SPARK PLUG EUROPE GmbH. La reproducción total o parcial de esta publicación está estrictamente prohibida sin una autorización previa por escrito de NGK SPARK PLUG EUROPE GmbH.

NL

Deze catalogus vervangt alle eerdere catalogi. NGK SPARK PLUG EUROPE GmbH heeft alles in het werk gesteld om voor nauwkeurige informatie te zorgen, op basis van de informatie die voorhanden was op het moment dat de catalogus werd samengesteld. Deze catalogus dient slechts ter informatie. NGK SPARK PLUG EUROPE GmbH aanvaardt geen aansprakelijkheid voor eventuele onnauwkeurigheden. Producten die in verband worden gebracht met voertuigen of gereedschaptoepassingen van deze publicatie worden beschouwd onder normale gebruiksomstandigheden, geïnstalleerd door een professional en voor voertuigen die in Europa zijn geregistreerd. Voor alle andere

gebruik of retrofitting aanvaardt NGK geen aansprakelijkheid. Alle bestelde producten vallen onder de geldige algemene voorwaarden van NGK SPARK PLUG EUROPE GmbH. De lijst met kruisverwijzingen (pagina 293–390) dient als leidraad. Door verschillen in ontwerp, materialen, enz. kunnen producten die door verschillende fabrikanten zijn vervaardigd afwijken. Zie ook onze aanbeveling voor het juiste gebruik van het product dat u gekocht heeft. Afbeeldingen, schema's en tekeningen in deze publicatie zijn niet bindend. Afbeeldingen, schema's, tekeningen en andere grafische elementen en gegevens zijn exclusief eigendom van NGK SPARK PLUG EUROPE GmbH. Gedeeltelijke of volledige reproductie van deze publicatie is ten strengste verboden zonder schriftelijke toestemming vooraf van NGK SPARK PLUG EUROPE GmbH.

PT

Este catálogo substitui todos os catálogos anteriores. NGK SPARK PLUG EUROPE GmbH emvidou os seus melhores esforços para assegurar uma informação precisa, com base nas informações disponíveis no momento da compilação do catálogo. Este catálogo é elaborado apenas para efeitos informativos. NGK SPARK PLUG EUROPE GmbH não aceita qualquer responsabilidade por qualquer imprecisão. A ligação do produto a aplicações de veículos ou ferramentas desta publicação é considerada sob condições normais de uso, montado por um profissional e para veículos matriculados na Europa. Para todos os usos diferentes ou pós-equipamento, a responsabilidade de NGK não pode se comprometer. Todos os produtos encomendados estão sujeitos a termos e condições válidos fornecidos pela NGK SPARK PLUG EUROPE GmbH. Esta lista de referência cruzada (página 293–390) é fornecida como guia. Devido a diferenças em termos de design, materiais, etc., os produtos dos vários fabricantes poderão não corresponder. Consequentemente, consulte a nossa recomendação quanto à utilização adequada do produto adquirido. As fotos, diagramas e desenhos nesta publicação não são contratuais. A propriedade das fotos, diagramas, desenhos e outros elementos gráficos e dados pertencem exclusivamente a NGK SPARK PLUG EUROPE GmbH. A reprodução desta publicação, parcial ou integral, é estritamente proibida sem uma autorização prévia por escrito da NGK SPARK PLUG EUROPE GmbH.

GR

Αυτός ο κατάλογος αντικαθιστά όλους τους προηγούμενους καταλόγους. Η NGK SPARK PLUG EUROPE GmbH έχει κάνει κάθε δυνατή προσπάθεια για να εξασφαλιστεί η ακριβής πληροφόρηση, βάσει των διαθέσιμων πληροφοριών κατά το χρόνο της κατάρτισης του καταλόγου. Αυτός ο κατάλογος έχει στόχο μόνο την πληροφόρηση. Η NGK SPARK PLUG EUROPE GmbH δεν αναλαμβάνει καμία ευθύνη για οποιαδήποτε ανακρίβεια. Η σύνδεση του προϊόντος σε οχήματα ή εφαρμογές εργαλείων του παρόντος καταλόγου θεωρείται ότι γίνονται υπό κανονικές συνθήκες χρήσης, με εγκατάσταση από επαγγελματία και για τα οχήματα που έχουν ταξινομηθεί στην Ευρώπη. Για όλες τις άλλες περιπτώσεις διαφορετικής χρήσης ή προσθήκης εξοπλισμού, δεν φέρει ευθύνη η NGK. Όλα τα παραγγελθέντα προϊόντα υπόκεινται σε έγκυρους όρους και προϋποθέσεις που παρέχονται από την NGK SPARK PLUG EUROPE GmbH. Αυτή η λίστα παραπομπών (σελ. 293–390) παρέχεται ως οδηγός. Λόγω των διαφορών στη σχεδίαση, στα υλικά κ.λπ., τα προϊόντα από διάφορους κατασκευαστές ενδέχεται να παρουσιάζουν ασυμφωνίες. Συνεπώς, ανατρέξτε στις συστάσεις μας για την ενδεδειγμένη χρήση του προϊόντος που έχετε αποκτήσει. Εικόνες, διαγράμματα και σχέδια σε αυτήν την έκδοση δεν αποτελούν μέρος σύμβασης. Οι εικόνες, διαγράμματα, σχέδια και άλλα γραφικά στοιχεία και δεδομένα αποτελούν αποκλειστική ιδιοκτησία της NGK SPARK PLUG EUROPE GmbH. Απαγορεύεται αυστηρά η ολική ή μερική αναπαραγωγή της δημοσίευσης χωρίς την προηγούμενη γραπτή άδεια της Spark Plug NGK Europe GmbH.

TR

Bu katalog önceki tüm katalogların yerini alır. NGK SPARK PLUG EUROPE GmbH, bu katalogun hazırlanma aşamasında mevcut olan bilgilere dayanarak doğru bilgiler vermek için elinden geleni yapmıştır. Bu katalog yalnızca bilgi amaçlı hazırlanmıştır. NGK SPARK PLUG EUROPE GmbH, herhangi bir hata için sorumluluk kabul etmez. Bu yayındaki taşıt ve araç uygulamalarına atıfta bulunan ürün bağlantıları verilirken normal kullanım koşulları, bir uzmanca takılmış olması göz önünde bulundurulmuştur ve Avrupa'da tescillenmiş taşıtlar içindir. Farklı herhangi bir kullanım veya sonradan takılan ekipmanlar için NGK sorumlu tutulamaz. Sipariş edilen tüm ürünler, NGK SPARK PLUG EUROPE GmbH tarafından sağlanan geçerli şartlara ve koşullara tabidir. Çapraz referans listesi (sayfa 293–390) bir kılavuz olarak verilmiştir. Not: Bu tablo referans amaçlıdır. Tasarım, malzeme ve benzeri şeylerdeki farklılıklar sebebiyle, farklı üreticilerin ürünleri eşleşmeyebilir. Bu yüzden alınan ürünün uygun kullanımı ile ilgili tavsiyelerimize bakın. Bu yayındaki resimler, şemalar ve çizimler taahhüt değildir. Resimlerin, çizimlerin ve diğer grafik öğelerin mülkiyeti yalnızca NGK SPARK PLUG EUROPE GmbH'ye aittir.

Bu yayının NGK SPARK PLUG EUROPE GmbH'den önceden yazılı izin almadan kısmi veya tam olarak yeniden çoğaltılması kesinlikle yasaktır.

PL

Niniejszy katalog zastępuje wszystkie poprzednie katalogi. Firma NGK SPARK PLUG EUROPE GmbH dołożyła najlepszych starań, aby upewnić się, że katalog zawiera precyzyjne informacje opierające się na danych dostępnych w czasie opracowania katalogu. Niniejszy katalog ma charakter wyłącznie informacyjny. Firma NGK SPARK PLUG EUROPE GmbH nie ponosi żadnej odpowiedzialności za jakiegokolwiek nieprecyzyjne dane. Przystosowanie produktów do pojazdów lub narzędzi wymienionych w niniejszej publikacji zakłada normalne warunki stosowania, montaż przez profesjonalistów oraz pojazdy zarejestrowane w Europie. Firma NGK nie ponosi żadnej odpowiedzialności za jakiegokolwiek przypadki innych zastosowań lub stosowanie w sprzęcie innego rodzaju. Wszystkie zamówione produkty podlegają odpowiednim warunkom i postanowieniom określonym przez firmę NGK SPARK PLUG EUROPE GmbH. Załączona lista porównawcza (strony 293–390) powinna być traktowana jedynie jako wskazówka. Ze względu na różnice w kształcie, zastosowanych materiałach itp., produkty poszczególnych producentów mogą się różnić między sobą. Z powyższych powodów prosimy stosować się do zaleceń dotyczących użytkowania produktu. Ilustracje, schematy i rysunki zawarte w niniejszej publikacji nie mają mocy umownej. Ilustracje, schematy, rysunki i inne elementy graficzne oraz dane należą wyłącznie do firmy NGK SPARK PLUG EUROPE GmbH. Reprodukacja niniejszej publikacji w części lub w całości jest surowo zabroniona bez uzyskania wcześniejszego pisemnego upoważnienia ze strony firmy NGK SPARK PLUG EUROPE GmbH.

CZ

Tento katalog nahrazuje všechny předchozí katalogy. NGK SPARK PLUG EUROPE GmbH vyvinul co největší úsilí, aby poskytl nej přesnější informace, založených na informacích dostupných v okamžiku sestavení katalogu. Tento katalog je jen pro informační účely. NGK SPARK PLUG EUROPE GmbH nepřebírá žádnou zodpovědnost na případné nepřesnosti. Propojení jednotlivých produktů s vozidly nebo použití s nářadím z této publikace se počítají za normálních podmínek užívání, nastavených odborníky pro vozidla registrovaná v Evropě. NGK se nezavazuje k odpovědnosti za jiné užití nebo pro následné vybavení. Všech objednaných výrobků se týkají platné podmínky a dohody dodávek NGK SPARK PLUG EUROPE GmbH. Seznam křížových odkazů (strana 293–390) je dodán jako průvodce. Vzhledem k rozdílům v designu, materiálech atd. se produkty od různých výrobců nemusejí shodovat. Proto se

podívejte na naše doporučení ohledně řádného použití zakoupeného produktu. Obrázky, diagramy a kresby v této publikaci nejsou závazné. Vlastnictví obrázků, diagramů, kreseb a dalších grafických prvků a dat jsou výhradním majetkem NGK SPARK PLUG EUROPE GmbH. Jakákoliv reprodukce této publikace, ať části nebo v celku je přísně zakázána bez písemné autorizace NGK SPARK PLUG EUROPE GmbH.

HU

Ez a katalógus hatályon kívül helyez minden korábbi katalógust. NGK SPARK PLUG EUROPE GmbH mindent megtett annak érdekében, hogy a katalógus összeállításakor rendelkezésre álló információkon alapuló pontos tájékoztatást biztosítson. Ez a katalógus csak tájékoztató jellegű. NGK SPARK PLUG EUROPE GmbH nem vállal felelősséget az esetleges pontatlanságokért. A jelen katalógusban szereplő járműhöz kapcsolódó elemek, vagy alkalmazási eszközök használata szokásos alkalmazási feltételek mellett értendő, és azokat szakembernek kell az Európában bejegyzett járművekbe szerelnie. Minden ettől eltérő használatért, vagy utólagos beszerelésért az NGK semmiféle felelősséget nem vállal. Valamennyi megrendelt termékre az NGK SPARK PLUG EUROPE GmbH által meghatározott feltételek vonatkoznak. A kiadványban szereplő ábrák, diagramok és rajzok nem szerződéses jellegűek.

A kereszthivatkozás lista (293–390 oldal) csak útmutatóként szolgál. A különböző gyártók által gyártott termékek tervezésében, az anyagaiban, stb. eltérések lehetnek. Ezért vegye figyelembe ajánlásainkat a megvásárolt termék a helyes használatához. A kiadványban szereplő ábrák, diagramok, rajzok és egyéb grafikus elemek és adatok kizárólag az NGK SPARK PLUG EUROPE GmbH tulajdonát képezik. A kiadvány részleges vagy teljes reprodukciója kizárólag az NGK SPARK PLUG EUROPE GmbH előzetes és írásos engedélyezésével történhet.

RU

Данный каталог заменяет все ранее изданные каталоги. Компания NGK SPARK PLUG EUROPE GmbH предприняла все возможные усилия, чтобы обеспечить точность данных, подготовленных на основе доступной на момент составления каталога информации. Данный каталог предназначен только для информационных целей. NGK SPARK PLUG EUROPE GmbH не несет ответственность за какие-либо неточности. Примеры установки продуктов в транспортные средства или использования инструментов в данном издании рассматриваются для случаев нормального режима эксплуатации, профессионального монтажа и транспортных средств, зарегистрированных в Европе. При любых других условиях ответственность за

последствия использования оборудования NGK не несет. На все заказанные продукты распространяются действующие условия и положения NGK Spark Plug Europe GmbH.

других производителей (стр. 293–390) предоставлен в качестве справочного материала. Продукты разных производителей могут не соответствовать друг другу вследствие отличий в конструкции, материалах и т. п. Просим вас руководствоваться нашими рекомендациями по надлежащему использованию приобретенного продукта. Изображения, графики и рисунки в данном издании не являются договорными. Права на изображения, графики, рисунки и прочие графические элементы и данные принадлежат исключительно NGK SPARK PLUG EUROPE GmbH. Воспроизведение данного издания, частично или полностью, строго запрещается без предварительного письменного разрешения NGK SPARK PLUG EUROPE GmbH.

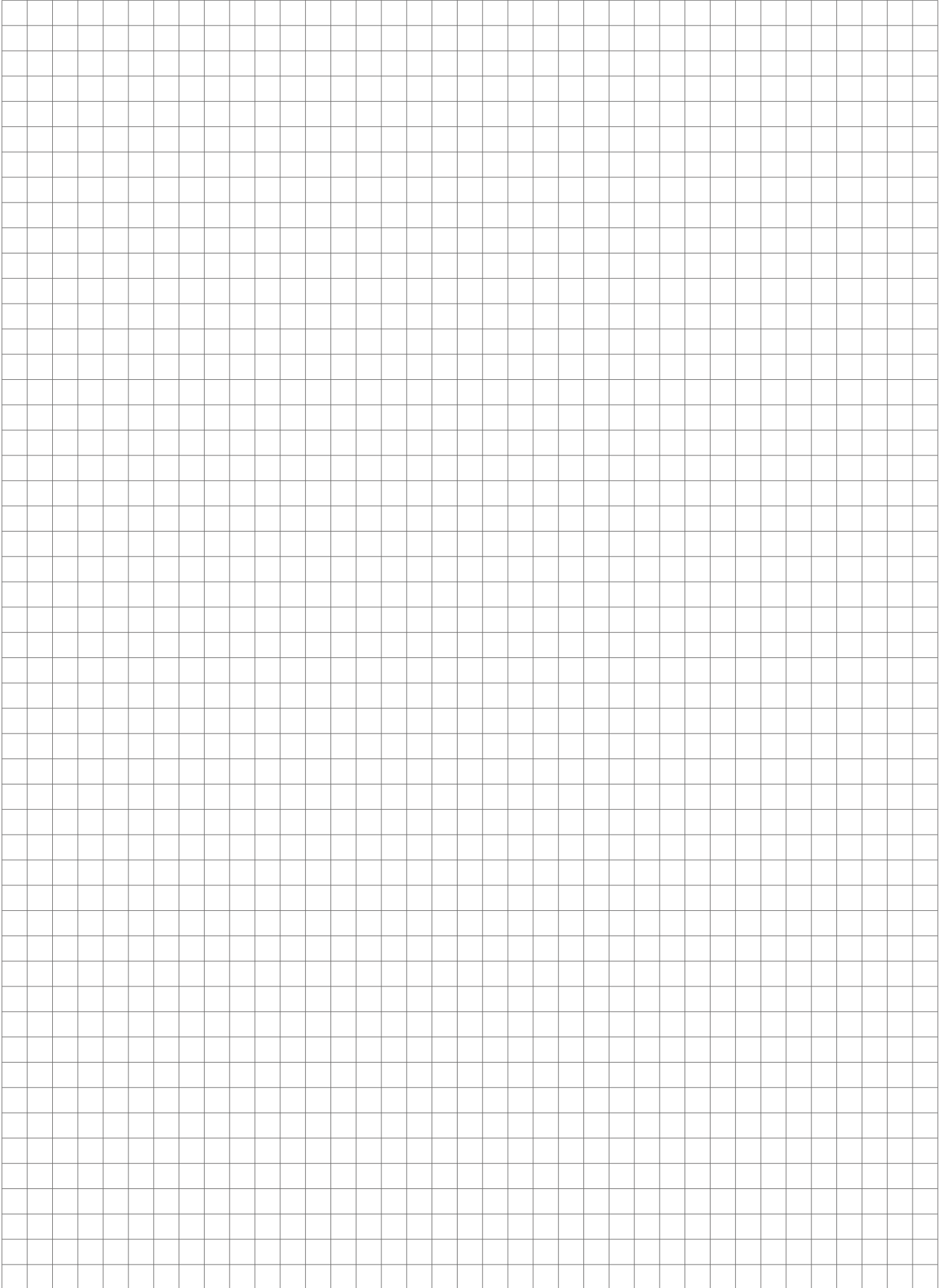



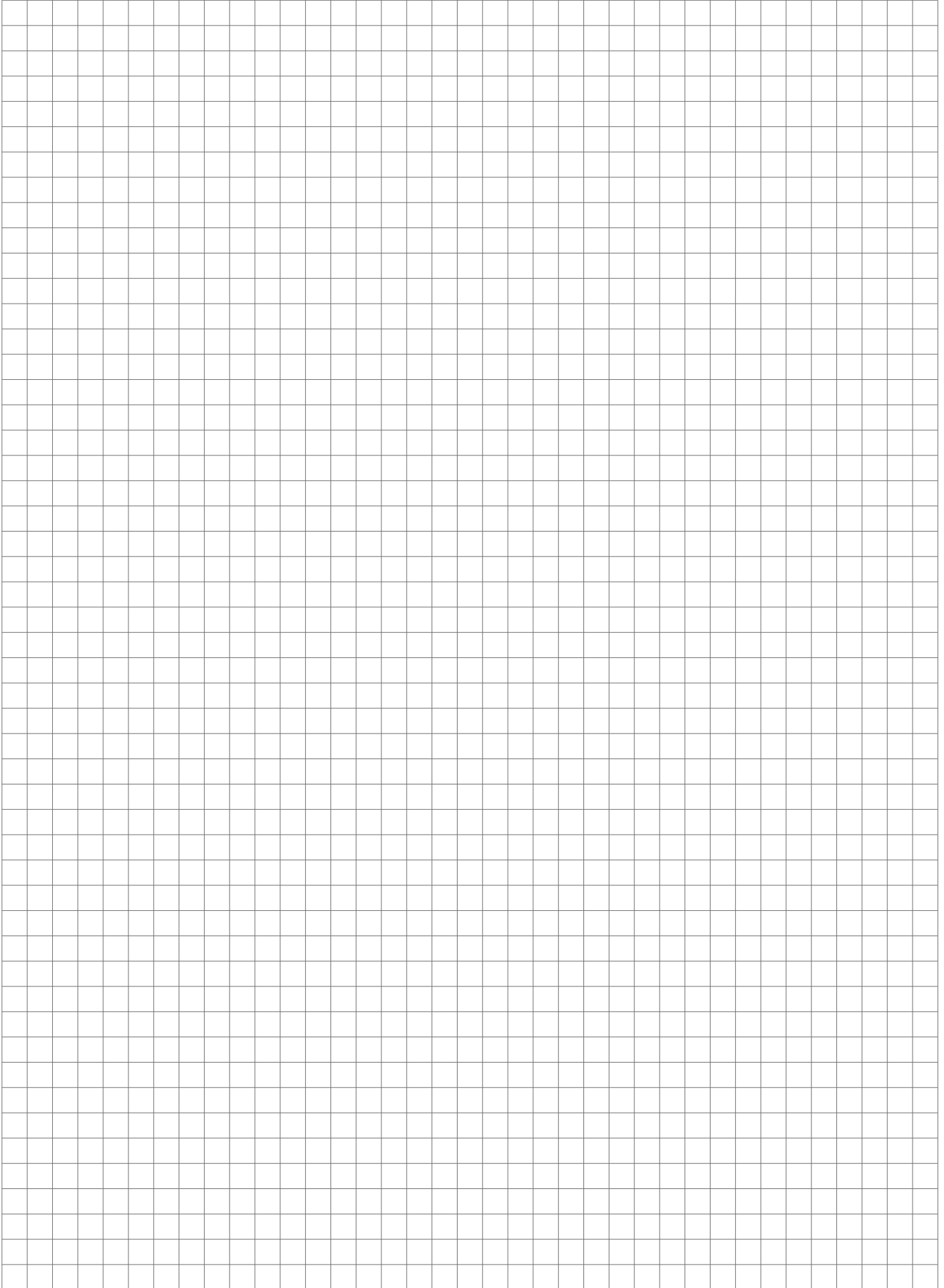



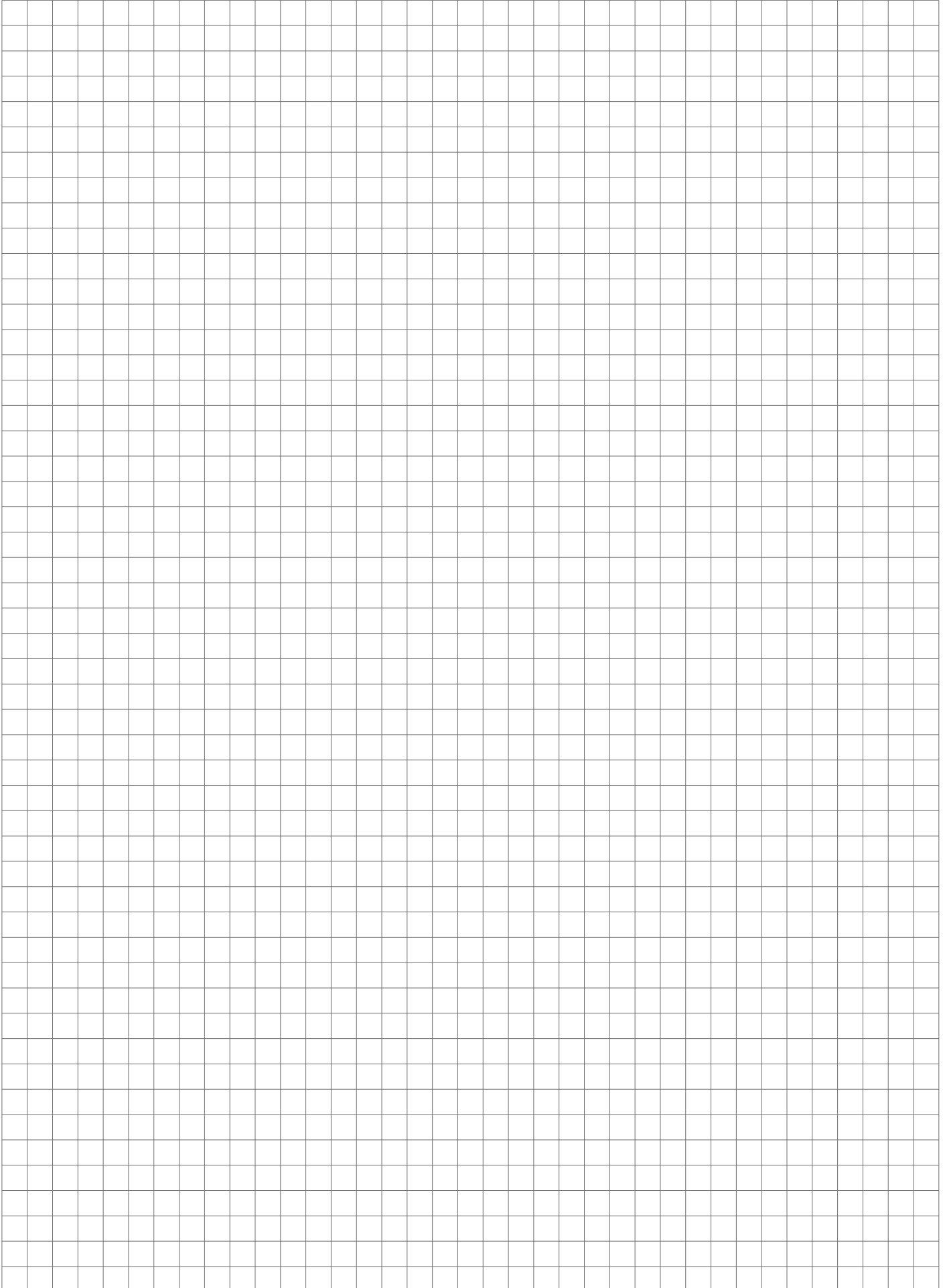



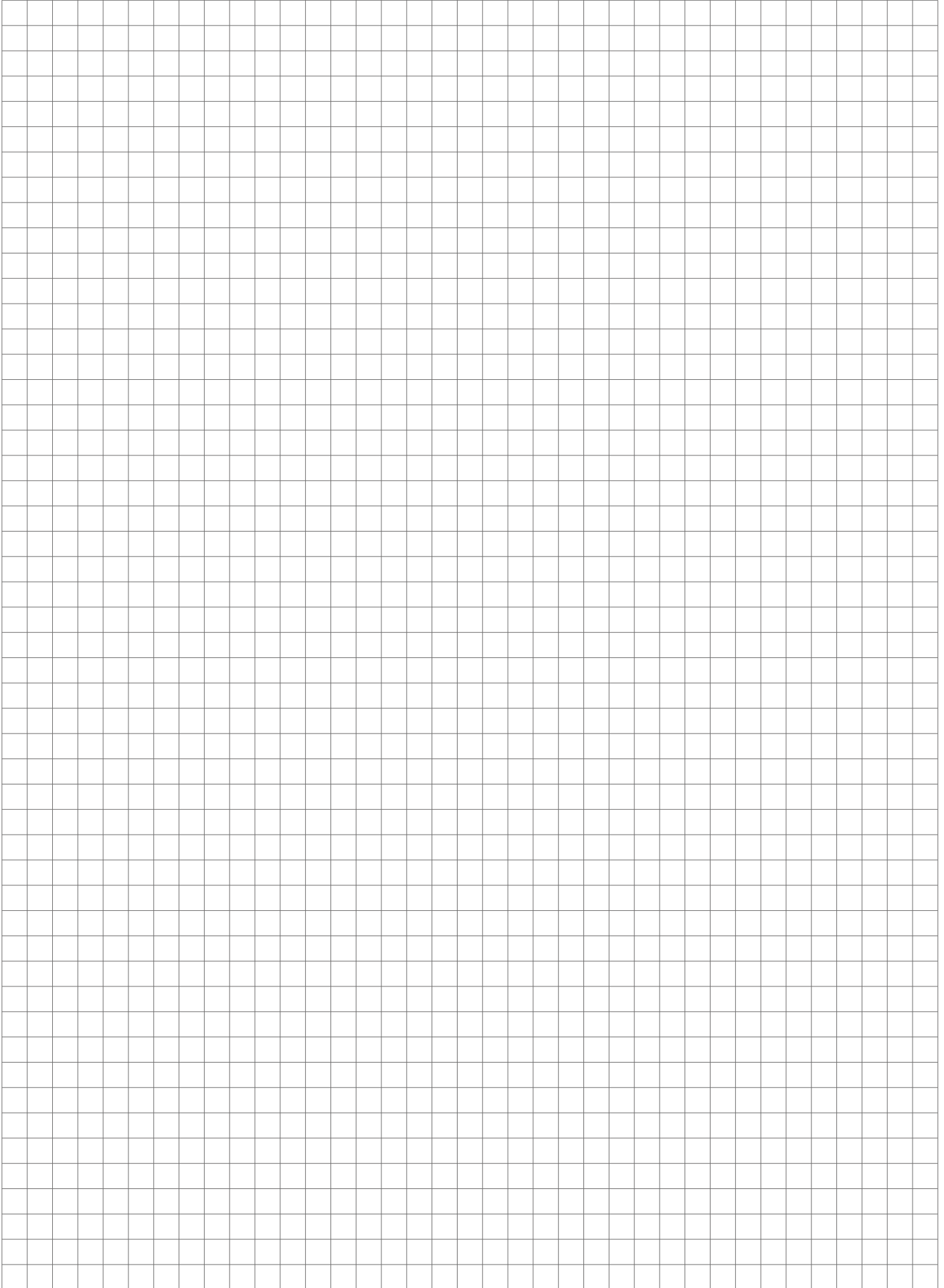

PRODUCT PORTFOLIO



IGNITION PARTS



VEHICLE ELECTRONICS

NGK and NTK offers a comprehensive range of products for the Aftermarket. Four markets (automotive, motorcycle, power tools, and marine) are supplied with more than 60,000 applications covering eight product lines.

With its two strong brands and countless products to choose from, NGK and NTK is the world's largest supplier of spark plugs and oxygen sensors. While NGK Ignition Parts stands for the ultimate in performance – from spark plugs and glow plugs to ignition coils and ignition leads –, NTK Vehicle Electronics, the precision brand, offers vehicle electronics and great business opportunities.

All we do, innovate and produce, perfectly reflects our ultimate aim: Performance through Precision, Precision for Performance.



NGK – POWERED BY PERFORMANCE

- Spark Plugs
- Glow Plugs
- Ignition Coils
- Ignition Leads

NTK – POWERED BY PRECISION

- Oxygen Sensors
- Temperature Sensors
- MAF/MAP Sensors
- Engine Speed Position Sensors

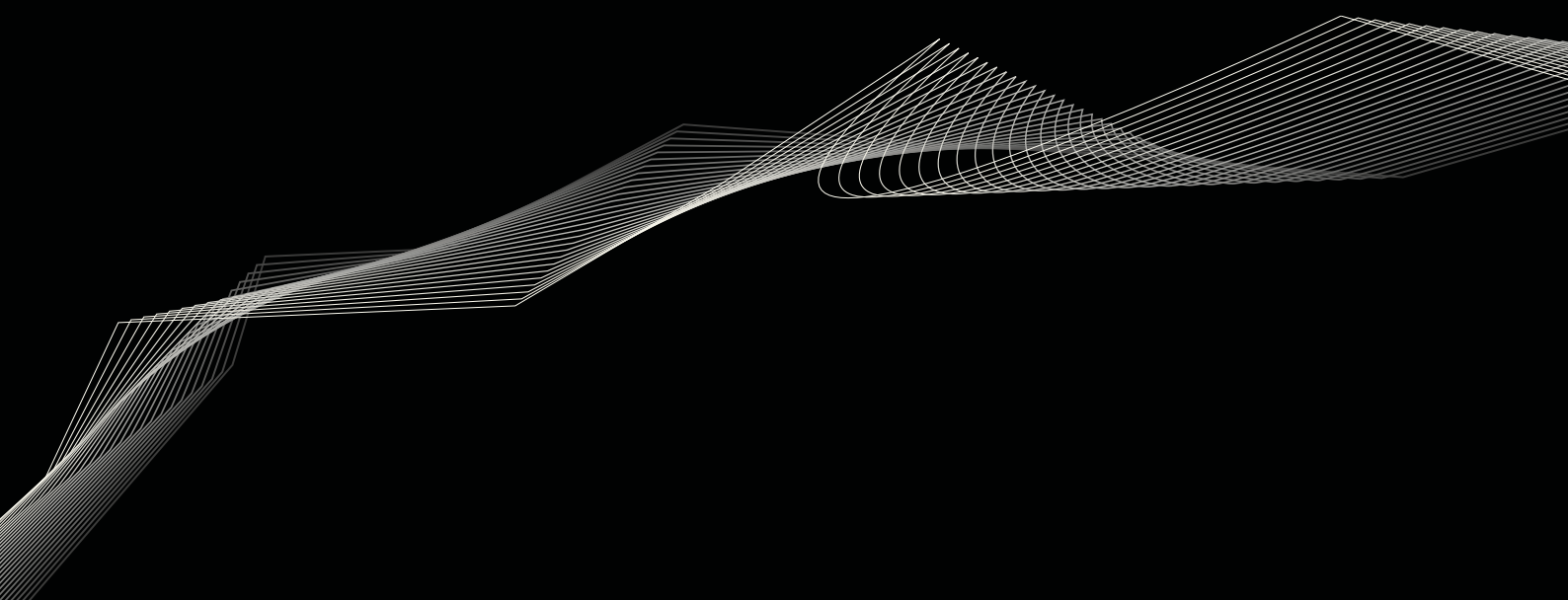

NGK SPARK PLUG EUROPE GmbH

Harkortstraße 41 // 40880 Ratingen // Germany
Tel.: +49 (0) 2102 974-000 // Fax.: +49 (0) 2102 974-149
www.ngkntk.com



NGK | NTK
SPARK PLUGS | TECHNICAL CERAMICS
NGK SPARK PLUG EUROPE GmbH